

MON/FAYETTE EXPRESSWAY

Construction Activity Weekly Updates



Planned Construction Activities for the Week of July 10, 2023

SECTION 53A1 • JEFFERSON HILLS BOROUGH, ALLEGHENY COUNTY

Contractor: Trumbull Corp

1. Work Shift

- The contractor is working 10-hour day shifts. Their standard work shift is 6:00 AM to 4:00 PM, Monday to Thursday. Friday and Saturday shifts will be utilized as needed.

2. Traffic

- An Allegheny County construction project has Coal Valley Road closed and detoured.
- Periodic single lane closure flagging will occur for paving the temporary SR885 runaround, traffic marking painting, and guiderail installation.
- Traffic shifts have been implemented on PTC 43 Northbound and Southbound at the Jefferson Blvd. Interchange.
- Construction traffic exiting and entering SR 51 NB at Peters Creek.
- Brickyard Road will have traffic restrictions during working hours.

3. Earthwork

- Sediment basins are being constructed for runoff control. Runoff to be stored and slowly released.
- SR 885 temporary run around is scheduled to be paved.
- Large off road trucks are being assembled.
- The overexcavation and geotechnical treatments for the future highway embankments will continue.
- Pre-blast survey questionnaires have been distributed to property owners within 1,000' of the blasting limits. Blasting is planned to begin in mid July.



A top view of drilled concrete caisson pier foundations for one of the bridges over S.R. 51.

MON/FAYETTE EXPRESSWAY

Construction Activity Weekly Updates



Planned Construction Activities for the Week of July 10, 2023

4. Roadway and Bridge Work

- Foundation micropile drilling and installation continues for the bridge over Jefferson Blvd and SR 51 bridge MF-400/401 abutments.
- Concrete placements will continue for the pier footings, columns and caps for bridges that go over SR 51/Peters Creek. Updated diagram shown below.
- Driven steel H-piles are being installed for pier footings.
- Drilled shafts are being constructed for pier footings.

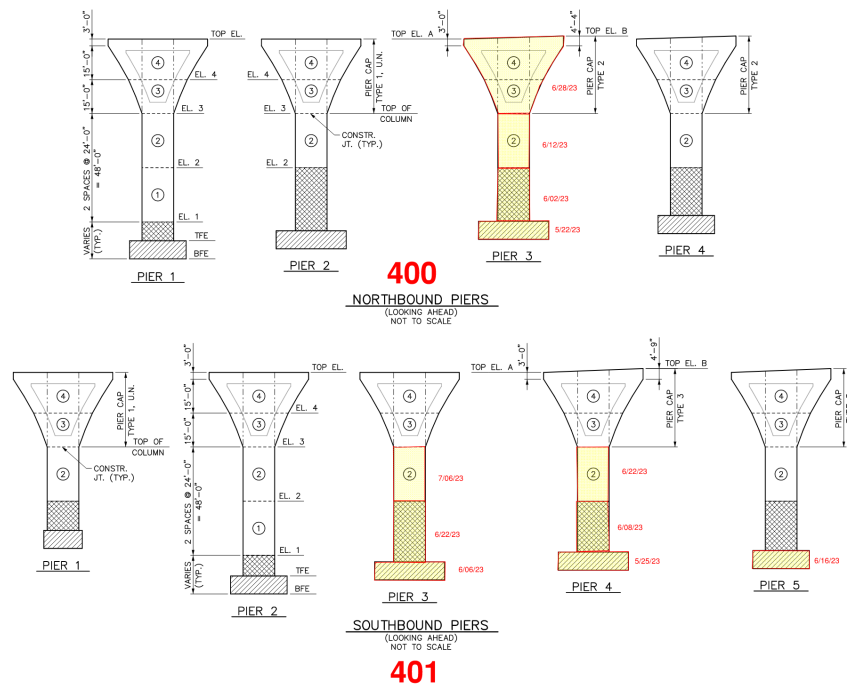

5. Noise/Dust/Runoff Control

- Erosion control measures are being installed as construction advances and will be maintained as needed.
- Rock construction entrances are installed throughout the project for contractor access at various locations. The temporary access points will be maintained as needed.
- A street sweeper is on-site and will be used clean local roadways when needed.
- Water trucks are on-site and will be utilized to control dust when needed.

SECTION 53A1 – ESTIMATED COMPLETION DATE: Late 2026

Learn more about the Mon/Fayette Expressway by visiting the project website.