

MON/FAYETTE EXPRESSWAY

Construction Activity Weekly Updates



Planned Construction Activities for the Week of August 7, 2023

SECTION 53A1 • JEFFERSON HILLS BOROUGH, ALLEGHENY COUNTY

Contractor: Trumbull Corp

1. Work Shift

- The contractor is working 10-hour day shifts. Their standard work shift is 6:00 AM to 4:00 PM, Monday to Thursday. Friday and Saturday shifts will be utilized as needed.

2. Traffic

- An Allegheny County construction project has Coal Valley Road closed and detoured.
- The SR 885 Temporary Runaround has been completed. Traffic is now utilizing the temporary pavement.
- SR 885 truck crossing in use with flaggers for large off-road trucks. Flagging will be utilized when trucks are crossing the roadway.
- Traffic shifts have been implemented on PTC 43 Northbound and Southbound at the Jefferson Blvd. Interchange. Crossover has been paved for future use.
- Construction traffic exiting and entering SR 51 NB at Peters Creek.
- Brickyard Road will have traffic restrictions during working hours. Left turns are temporarily prohibited exiting Brickyard Road onto SR 51.
- New digital message boards on SR 51 are functioning and will be displaying a test message.

3. Earthwork

- Tree clearing will begin north of New England Road towards Camp Hollow Road. This tree clearing is being performed in preparation for the next construction section (53A2) that will bid in late September 2023.
- Sediment basins are constructed for runoff control. Runoff to be stored and slowly released.
- Large off-road trucks are in use to transport excavated material within the project.
- Excavation for the new highway that crosses under SR 885 continues.
- Pre-blast survey questionnaires have been distributed to property owners within 1,000' of the blasting limits. This survey is nearing completion.
- Blasting is anticipated to begin the week of August 7th and will continue through December 2025. Blasting will typically occur between 3:00 PM and 5:00 PM. For all blasts, 5 minutes prior to blasting the contractor will give 3 horn alerts of 15 seconds each. 1 minute prior to blasting, 3 horn alerts of 10 seconds will be sounded. 30 seconds prior to blasting, a series of short horn alerts will be sounded up to the time of detonation. After the blast, the area will be checked, and a horn will be sounded for 15 seconds to indicate that "all is clear". The warning sirens are intended to clear the work area and may or may not be heard at neighboring properties.



Future bridge crossing at Coal Valley Road

MON/FAYETTE EXPRESSWAY

Construction Activity Weekly Updates



Planned Construction Activities for the Week of August 7, 2023

4. Roadway and Bridge Work

- Foundation micropile drilling and installation continues for the bridge over Jefferson Blvd MF-402 and SR 51 bridge MF-400/401 abutments.
- Bridge over Jefferson Blvd Abutment 1 foundation concrete placed. Abutment 2 to follow after the micro pile foundation is complete.
- Concrete placements will continue for the pier footings, columns and caps for bridges that go over SR 51/Peters Creek. See below for depiction.
- Temporary Excavation Shoring is being installed for new piers and abutments.
- The future SR 885 Bridge Abutment 1 foundation is constructed.

5. Noise/Dust/Runoff Control

- Erosion control measures are being installed as construction advances and will be maintained as needed.
- Diversion ditches have been constructed to take runoff water to sediment basins.
- Rock construction entrances are installed throughout the project for contractor access at various locations. The temporary access points will be maintained as needed.
- A street sweeper is on-site and will be used clean local roadways when needed.
- Water trucks are on-site and will be utilized to control dust when needed.

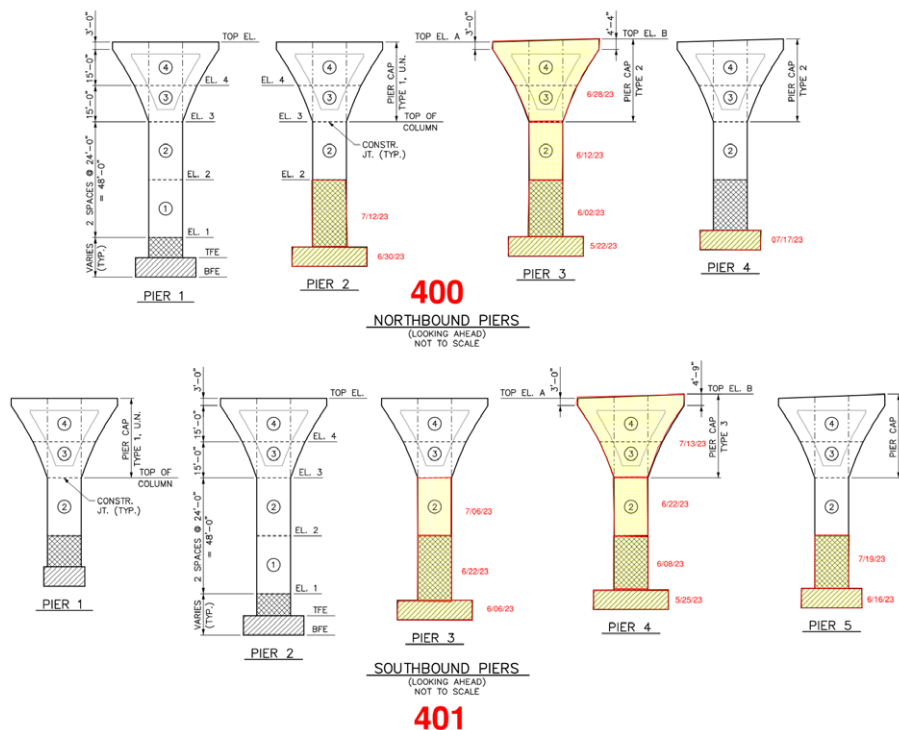

SECTION 53A1 – ESTIMATED COMPLETION DATE: Late 2026

Learn more about the Mon/Fayette Expressway by visiting the project website.