

# MON/FAYETTE EXPRESSWAY

## Construction Activity Weekly Updates



Planned Construction Activities for the Week of August 14, 2023

## SECTION 53A1 • JEFFERSON HILLS BOROUGH, ALLEGHENY COUNTY

**Contractor: Trumbull Corp**

### 1. Work Shift

- The contractor is working 10-hour day shifts. Their standard work shift is 6:00 AM to 4:00 PM, Monday to Thursday. Friday and Saturday shifts will be utilized as needed.

### 2. Traffic

- An Allegheny County construction project has Coal Valley Road closed and detoured.
- The SR 885 Temporary Runaround has been completed. Traffic is now utilizing the temporary pavement.
- SR 885 truck crossing in use with flaggers for large off-road trucks. Flagging will be utilized when trucks are crossing the roadway.
- Traffic shifts have been implemented on PTC 43 Northbound and Southbound at the Jefferson Blvd. Interchange. A temporary crossover has been paved for traffic staging.
- Construction traffic exiting and entering SR 51 NB at Peters Creek.
- Brickyard Road will have traffic restrictions during working hours. No left turn existing Brickyard Road onto SR 51.
- New digital message boards on SR 51 are functioning and will be displaying a test message.

### 3. Earthwork

- Tree clearing is occurring north of New England Road and Camp Hollow Road along the new alignment for the highway.
- Sediment basins are constructed for runoff control. Runoff to be stored and slowly released.
- Large off-road trucks are in use to transport excavated material within the project.
- Excavation for the new highway that crosses under SR 885 has begun.
- Pre-blast survey questionnaires have been distributed to property owners within 1,000' of the blasting limits. Completed.
- The first blast occurred on Aug 9, 2023 and will continue through December 2025. Blasting will typically occur between 3:00 PM and 5:00 PM. For all blasts, 5 minutes prior to blasting the contractor will give 3 horn alerts of 15 seconds each. 1 minute prior to blasting, 3 horn alerts of 10 seconds will be sounded. 30 seconds prior to blasting, a series of short horn alerts will be sounded up to the time of detonation. After the blast, the area will be checked, and a horn will be sounded for 15 seconds to indicate that "all is clear". The warning sirens are intended to clear the work area and may or may not be heard at neighboring properties.



Workers use heavy equipment to construct a sediment basin along the Mon/Fayette Expressway.

# MON/FAYETTE EXPRESSWAY

## Construction Activity Weekly Updates



Planned Construction Activities for the Week of August 14, 2023

### 4. Roadway and Bridge Work

- Foundation micropile drilling and installation continues for the bridge over Jefferson Blvd MF-402 and SR 51 bridge MF-400/401 abutments.
- Bridge over Jefferson Blvd Abutment 1 Wall Concrete to be placed. Abutment 2 to follow after micro-piles completed.
- Concrete structure placements will continue for the pier footings, columns and caps for bridges that go over SR 51/Peters Creek. See below for depiction.
- Temporary Excavation Shoring is being placed for new piers and abutments.
- SR 885 Bridge Abutment 1 mud slab and foundation placed.

### 5. Noise/Dust/Runoff Control

- Erosion control measures are being installed as construction advances and will be maintained as needed. Measures are updated after storm events show weak areas.
- Diversion ditches have been constructed to take runoff water to sediment basins.
- Rock construction entrances are installed throughout the project for contractor access at various locations. The temporary access points will be maintained as needed.
- A street sweeper is on-site and will be used clean local roadways when needed.
- Water trucks are on-site and will be utilized to control dust when needed.

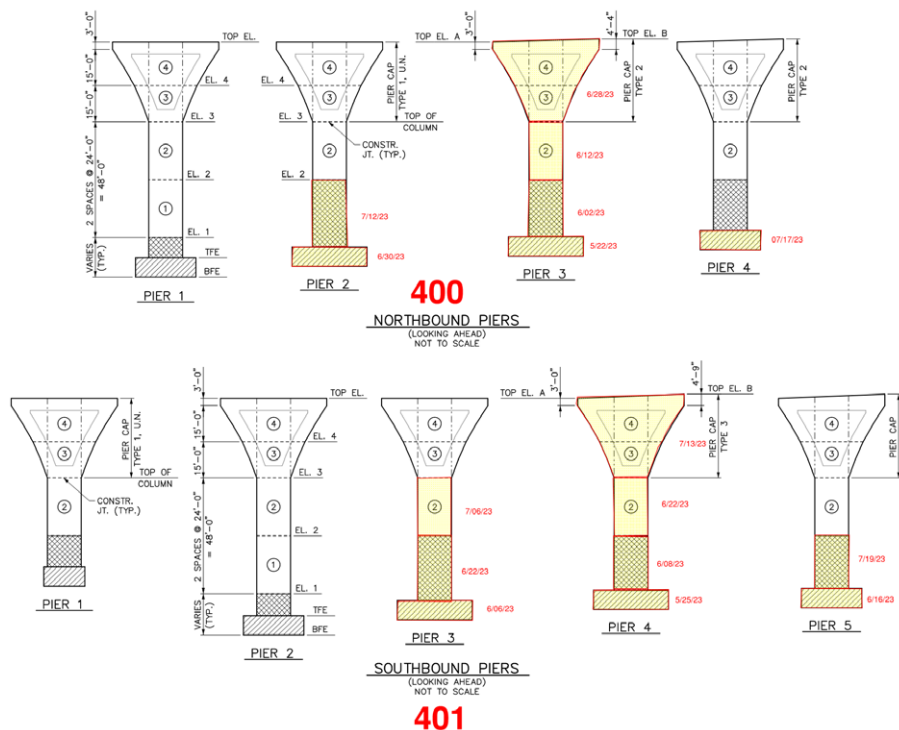

**SECTION 53A1 – ESTIMATED COMPLETION DATE: Late 2026**

Learn more about the Mon/Fayette Expressway by visiting the project website.