



Pennsylvania Turnpike Commission
Traffic Engineering & Operations

Maintenance and Protection of Traffic Standards

NOVEMBER 2025



Application

Pennsylvania Turnpike Commission (PTC) Maintenance and Protection of Traffic Standards applies to contractors; utilities; Federal, State, County, and Municipal governments; and others performing construction, maintenance, emergency, permit work, utility work, or any other type of work on highway or so closely adjacent to a highway that workers, equipment, or materials encroach on the roadway or interfere with the normal movement of traffic. This also includes any special event that necessitates the need for temporary traffic control. Refer to 67 Pa Code §212.402 for a complete list of types of work that are exempt from the requirements contained in this standard and the Manual on Uniform Traffic Control Devices (MUTCD).

The PTC Maintenance and Protection of Traffic Standard drawings mentioned hereafter will be referenced as PTS (Example: PTS 920-3).

PTC Maintenance and Protection of Traffic Standards have precedence over information found in PennDOT Publication 213 and the MUTCD. Furthermore, the PTS drawings shall be utilized in lieu of a Publication 213 or MUTCD Typical Application drawings when roadway conditions are similar (for example, PTS 910-4 would have precedence over PATA 306, PATA 603, and MUTCD TA-35 for a mobile operation on a multi-lane highway). PTS Applications (000 series) are general in nature and meant to be a possible component of temporary traffic control zones shown in most PTS drawings (910 through 940 series). Multiple PTS drawings (910-940 series) may be combined to create a customized temporary traffic control zone, however, customized traffic control setups shall be approved by the PTC prior to implementation. Install traffic control devices as shown on an approved customized traffic control plan if a PTS, Publication 213, or MUTCD Typical Application drawing does not apply.

The traffic control schemes shown in this standard are normally applicable for both urban and rural areas. Since it is not practical to provide detailed guidelines for all the situations that may conceivably arise, applications are presented for only the most common situations. These are minimum desirable applications for normal situations, and additional protection may be needed when special complexities or potential hazards prevail. The protection prescribed for each situation shall be consistent with the general provisions found in the most recent editions of 67 Pa Code, Chapter 212, Official Traffic Control Devices and the MUTCD as issued by the Federal Highway Administration and should be based on common sense; engineering judgment; the speed and volume of traffic; the duration of the operation; the exposure to potential hazards; the physical features of the highway including horizontal alignment, vertical alignment, and the presence of intersections and driveways; and other important factors.

Table of Contents

General
General Notes - Definitions
General Notes - Legend
PTS 000 – General Standards
PTS 001A: Milled or Binder Pavement Differential in Right Lane
PTS 001B: Milled or Binder Pavement Differential in Left Lane
PTS 002A: Milled or Binder Pavement Differential in Right and Center Lanes
PTS 002B: Milled or Binder Pavement Differential in Left and Center Lanes
PTS 003: Pavement Differential on Right Shoulder
PTS 004: Pavement Differential in Median Shoulder
PTS 005: Traffic Control Device Installation Sequence
PTS 006: Traffic Control Device Removal Sequence
PTS 007: Trailer-Mounted Equipment Placement and Delineation
PTS 008: Inlet / Junction Box Delineation
PTS 009: Temporary Impact Attenuator Delineation
PTS 010: Two-Lane Traffic Pace / Stoppage
PTS 011: Three-Lane Traffic Pace / Stoppage
PTS 012: WZSSC Stationary Shoulder Closure with Channelizing Devices
PTS 013: WZSSC Lane Closure with Channelizing Devices
PTS 014: WZSSC Stationary Shoulder Closure with Temporary Barrier
PTS 910 – Standards for Mobile Operations
PTS 910-1 Notes: General Notes
PTS 910-2: Mobile Shoulder Operations
PTS 910-3A: Mobile Operation for 2 Lanes – Right Lane and Shoulder Work Zone
PTS 910-3B: Mobile Operation for 2 Lanes – Left Lane and Median Work Zone
PTS 910-4A: Mobile Operation for 3 Lanes – Right and Center Lane Work Zone
PTS 910-4B: Mobile Operation for 3 Lanes – Left and Center Lane Work Zone
PTS 910-5A: Traffic Line Painting Operation for 2 Lanes – Right Lane
PTS 910-5B: Traffic Line Painting Operation for 2 Lanes – Left Lane
PTS 910-6A: Traffic Line Painting Operation for 3 Lanes – Right and Center Lane
PTS 910-6B: Traffic Line Painting Operation for 3 Lanes – Left and Center Lane
PTS 910-7: Mowing / Litter Cleanup Operations
PTS 920 – Standards for Short-Term Operations
PTS 920-1 Notes: General Notes
PTS 920-2: Stationary Shoulder Closure with Channelizing Devices
PTS 920-3: Single Lane Closure with Channelizing Devices
PTS 920-4: Dual Lane Closure with Channelizing Devices
PTS 920-5: Right Lane Closure within Transition from 2 to 3 Lanes
PTS 920-6: Center / Right Lane Closure within Transition from 2 to 3 Lanes
PTS 920-7A: Lane Closure Traffic Pattern for Interchange and Service Plaza Areas with Yield Control
PTS 920-7B: Lane Closure Traffic Pattern for Interchange and Service Plaza Areas with Stop Control
PTS 920-8: Multiple Single Lane Closure Traffic Patterns
PTS 920-9: Multiple Dual Lane Closure Traffic Patterns
PTS 920-10: Allegheny Tunnel Crossover Pattern
PTS 920-11: Tuscarora Tunnel Crossover Pattern

Table of Contents

PTS 920-12: Blue Mountain / Kittatinny Tunnel Crossover Pattern
PTS 920-13: Lehigh Tunnel Crossover Pattern
PTS 920-14: Survey Work Along Shoulder
PTS 920-15: Utility Work Along Shoulder

PTS 930 – Standards for Long-Term Operations
PTS 930-1 Notes: General Notes
PTS 930-2: Stationary Shoulder Closure with Channelizing Devices
PTS 930-3: Single Lane Closure with Channelizing Devices
PTS 930-4: Dual Lane Closure with Channelizing Devices
PTS 930-5: Right Lane Closure within Transition from 2 to 3 Lanes
PTS 930-6: Center / Right Lane Closure within Transition from 2 to 3 Lanes
PTS 930-7A: Lane Closure Traffic Pattern for Interchange and Service Plaza Areas with Yield Control
PTS 930-7B: Lane Closure Traffic Pattern for Interchange and Service Plaza Areas with Stop Control
PTS 930-8: Multiple Single Lane Closure Traffic Patterns
PTS 930-9: Multiple Dual Lane Closure Traffic Patterns
PTS 930-10: Allegheny Tunnel Crossover Pattern
PTS 930-11: Tuscarora Tunnel Crossover Pattern
PTS 930-12: Blue Mountain / Kittatinny Tunnel Crossover Pattern
PTS 930-13: Lehigh Tunnel Crossover Pattern
PTS 930-14A: Stationary Shoulder Closure with Temporary Barrier
PTS 930-14B: Multiple Stationary Shoulder Closures with Temporary Barrier
PTS 930-15: Single Lane Closure with Temporary Barrier
PTS 930-16A: Lanes Shift Detail – 2 Lanes Shift – Left
PTS 930-16B: Lanes Shift Detail – 2 Lanes Shift – Right
PTS 930-17A: Lanes Shift Detail – 3 Lanes Shift – Left
PTS 930-17B: Lanes Shift Detail – 3 Lanes Shift – Right
PTS 930-18: Crossover Traffic Pattern
PTS 930-19A: Emergency Pull-Off – Type I in Temporary Barrier
PTS 930-19B: Emergency Pull-Off – Type III
PTS 930-20: Opening in Temporary Barrier for Access to Construction Area
PTS 930-21: Combined Emergency Pull-Off – Type I and Opening in Temporary Barrier for Access to Construction Area
PTS 930-22: Access to Construction Area without Barrier
PTS 930-23: Opening in Temporary Barrier with Truck Crossing

PTS 940 – Standards for Interchange Operations
PTS 940-1 Notes: Interchange Operations – General Notes
PTS 940-2: Toll Plaza Right Lane Closure Operations Less Than 8 Hours
PTS 940-3: Toll Plaza Right Lane Closure Operations Between 8 and 72 Hours
PTS 940-4: Toll Plaza Right Lane Closure Operations More Than 72 Hours
PTS 940-5: Toll Plaza Center Lane Closure Operations Less Than 8 Hours
PTS 940-6: Toll Plaza Center Lane Closure Operations Between 8 and 72 Hours
PTS 940-7: Toll Plaza Center Lane Closure Operations More Than 72 Hours
PTS 940-8: Advance Warning Signs for Work on Ramps
PTS 940-9: Service Plaza Area Construction
PTS 940-10: Ramp Bridge Crossover
PTS 940-11A: Stationary Shoulder Closure on Ramp with Channelizing Devices
PTS 940-11B: Lane Narrows on Ramp with Channelizing Devices

Table of Contents

PTS 940-12A: Stationary Shoulder Closure on Ramp with Temporary Barrier	
PTS 940-12B: Lane Narrows on Ramp with Temporary Barrier	
PTS 940-13A: Single Lane Closure with Channelizing Devices for Dual Lane Ramp	
PTS 940-13B: Single Lane Closure with Temporary Barrier for Dual Lane Ramp	
PTS 940-14A: Slip Ramp – Lane Addition Closure with Channelizing Devices	
PTS 940-14B: Slip Ramp – Lane Closure with Channelizing Devices	
PTS 940-15A: Traffic Line Painting Operation for Single Lane Interchange Ramps	
PTS 940-15B: Traffic Line Painting Operation for Dual Interchange Ramps	
Appendix	
Appendix A: Sign Index in Nomenclature Order	

General Notes - Definitions (Page 1 of 2)

Buffer Zone (BZ) - Area that separates traffic flow from the work zone. Buffer zones must remain clear of equipment, vehicles, workers, and materials. The length of longitudinal buffer zone is defined on the PTS figures and may be increased for downgrades or other conditions that affect stopping sight distance.

- Longitudinal buffer zone is located in advance of and after the work zone.
- Lateral buffer zone is located between flowing traffic and the work zone area.

Clear Zone - The total roadside border area, starting at the edge of traveled way, available for safe use by errant vehicles.

Long Term - Work that occupies a location for more than 12 hours for more than three (3) consecutive days.

Mobile Operation - An operation where the work zone beginning and ending points move as the work activity moves. Work that moves intermittently or continuously for up to 24 hours.

PATA (Pennsylvania Typical Application) - Drawings within PennDOT Publication 213 that depict temporary traffic control conditions.

PCMS - Portable Changeable Message Sign

Portable Sign Post - Rigid device with steel posts for mounting temporary traffic control devices where minimum mounting heights of at least 5' are required. Refer to PennDOT Publication 111, Traffic Control - Pavement Markings and Signing Standards TC-8716, for details.

Portable Sign Support - A folding, collapsible, or telescoping device for posting temporary traffic control devices where minimum mounting heights of 1' are acceptable.

Roadway - That portion of a highway improved, designed, or ordinarily used for vehicular travel, exclusive of the sidewalk, berm, or shoulder.

Roll Ahead Space (RA) - Space provided between shadow vehicle and the work space. This space shall be clear of equipment, vehicles, workers, and materials.

Runout (R) - Length of the taper of a series of channelizing devices for the purpose of moving into the normal path. Located immediately after the end of the work zone.

Shadow Vehicle - A vehicle positioned within the activity in advance of the work zone and work vehicles. The primary purpose of the shadow vehicle is to provide advance information to approaching drivers while protecting workers and work vehicles. Shadow vehicles without a truck mounted attenuator must be a 33,000 lb GVW (Gross Vehicle Weight) or larger vehicle and loaded to weigh a minimum of 22,000 lbs., or as indicated on the Standard Drawings, in addition to meeting the requirements of PennDOT Publication 212. Vehicle must be equipped with a flashing, oscillating, or revolving amber warning light which is visible from any direction (360° visibility) and is not being used as a work vehicle. The amber warning light must be activated within an active work zone.

Short-Term - Work that occupies a location for less than 12 hours for three (3) or less consecutive days.

Shoulder - The part of a highway adjacent to the roadway which has a surface constructed with the same or similar material as the roadway. Shoulder width is measured from the center of the painted edge line to the outside edge of pavement, concrete, or finished distance.

Taper - A series of channelizing devices and/or temporary pavement markings installed for the purpose of moving traffic out of or into the normal path. Various taper types have differing minimum lengths, most of which are based up on an 'L' distance. The formula to determine distance L is shown on the corresponding PTS notes page. It should be noted that the taper length is a distance per lane; so if a single taper covers two lanes, the total taper length will be double the calculated or minimum distance.

- Merging Taper - Used when drivers in multiple lanes are required to merge into a common road space. Minimum length is L.
- Shifting Taper - Used when a lateral lane shift is needed.
- Shoulder Taper - Required on closed shoulders and on shoulders adjacent to a closed lane. Minimum length is 1/3L.

Truck Mounted Attenuators (TMA) - Shall be mandatory for placement on shadow vehicles, as indicated on the standard details. When a TMA is used, the weight of the shadow vehicle must be greater than the minimum weight specified by the TMA manufacturer.

General Notes - Definitions (Page 2 of 2)

Warning Lights – Yellow, White or Red lights that operate in steady burn or flashing mode. Warning lights on authorized vehicles may flash or revolve. Type A, B, C, and D warning lights are portable, powered, lens-directed enclosed lights.

Worker - A person on foot whose duties place him or her within the right-of-way of a highway, such as highway construction and maintenance forces, survey crews, utility crews, responders to incidents, and law enforcement personnel when directing traffic, investigating crashes, and handling lane closures, obstructed roadways, and disasters within the right-of-way of a highway.























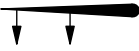







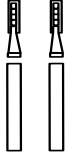

Work Vehicle - A vehicle available for use by workers within an activity area. All work vehicles shall be located outside of the buffer space and roll ahead space for shadow vehicles. Work vehicles being used in an active work zone must utilize the flashing, oscillating, or revolving amber warning lights which are visible from any direction (360° visibility).

Work Area - Area within a temporary traffic control zone that is set aside for workers, work vehicles, equipment, and material storage.

Work Zone (WZ) - The area of a highway where construction, maintenance, or utility work activities are being conducted, and in which traffic control devices are required in accordance with Title 67, Chapter 212.

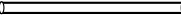
Work Zone Speed Safety Camera (WZSSC) - A system designed to enforce speed limits in work zones. The system uses speed measuring devices to detect and record motorists exceeding the posted speed limit in active work Zones.

General Notes - Legend for Pennsylvania Turnpike Commission Standard Details

	Work Zone		Arrow Board
	Buffer Zone		Arrow Board in Caution Mode
	Roll Ahead Space (RA)		Arrow Board in Merge Mode
	Milled pavement		
	Direction of traffic flow (Arrows)		Changeable Message Sign
	Work vehicle with an activated yellow (amber) or yellow (amber) and green warning light		Automated Lane Closure System
	Shadow vehicle with truck mounted attenuator (TMA) and activated amber warning light		Lane Control Signals Mast Arm
	Shadow vehicle with an activated amber warning light		Temporary Barrier
	Work Zone Speed Safety Camera (WZSSC) Device/Vehicle		Inlet / Junction Box
	Supply Vehicle		Temporary impact attenuator
	Line Painting Machine		Flagger
	Channelizing Device		Rock construction entrance or paved surface
	Channelizing Device with Sequential Flashing Light		
	Sign & Support		Toll Lane
	Type B White Flasher		Tolling Gantry
	Type B Yellow Flasher	or	
	Type B Red Flasher		
W/4"	Solid White Line/ Width		Trailer-Mounted Equipment
BW/4"	Broken White Line/ Width		Light Plant / Projected Light
Y/4"	Solid Yellow Line/ Width		
	Type III Barricade		

General Standards

(PTS 000 Series)

PTS 001A Milled or Binder Pavement Differential in Right Lane

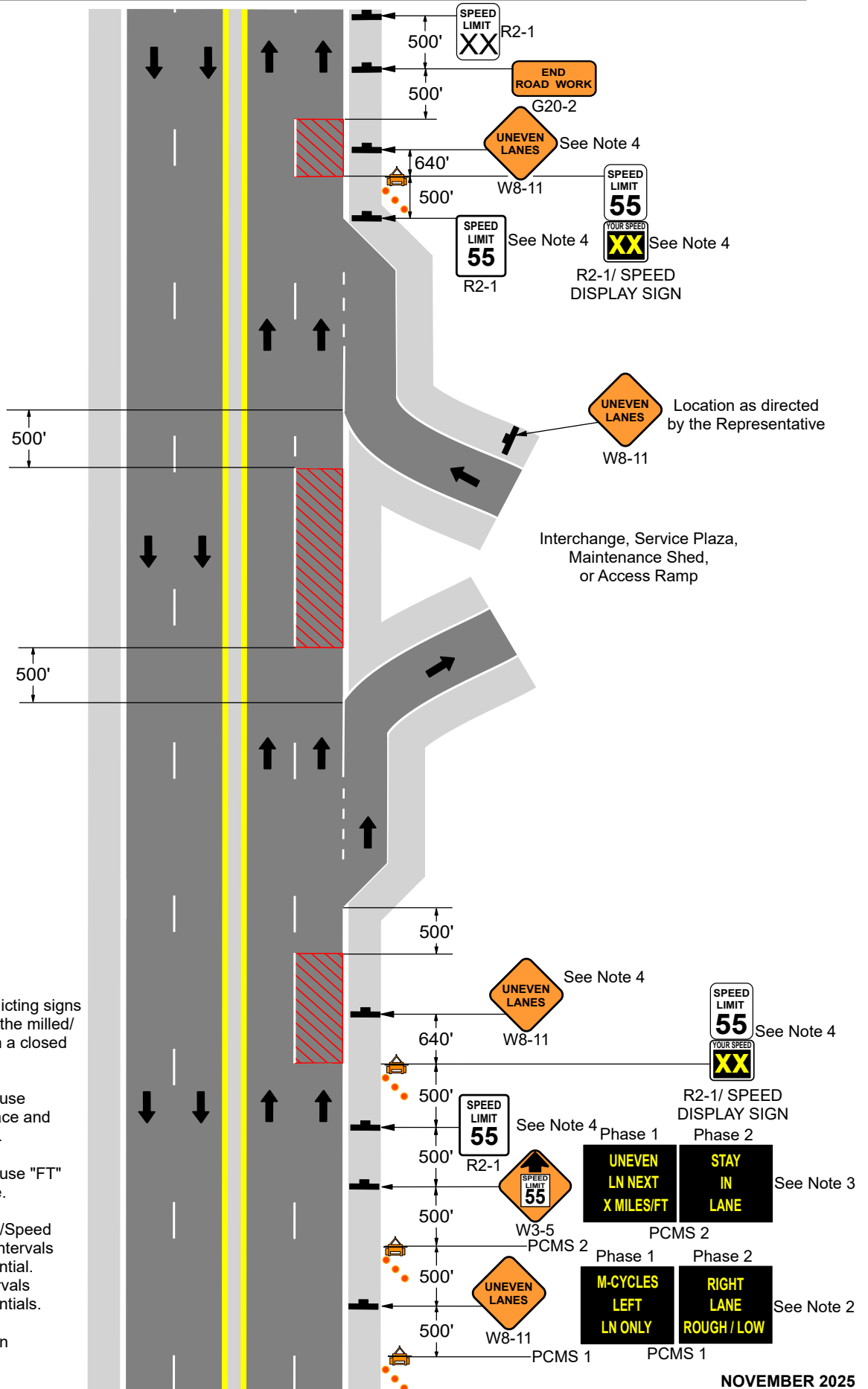

NOTES:

1. Completely cover conflicting signs and turn off PCMS when the milled/ binder pavement is within a closed lane.

2. For PCMS 1 Phase 2, use "ROUGH" for milled surface and "LOW" for binder surface.

3. For PCMS 2 Phase 1, use "FT" if distance is under 1 Mile.

4. Place W8-11 and R2-1/Speed Display Sign at 1/2 mile intervals through pavement differential. Place R2-1 at 1 mile intervals through pavement differentials.

5. See Appendix A for sign descriptions and sizes.

PTS 001B Milled or Binder Pavement Differential in Left Lane

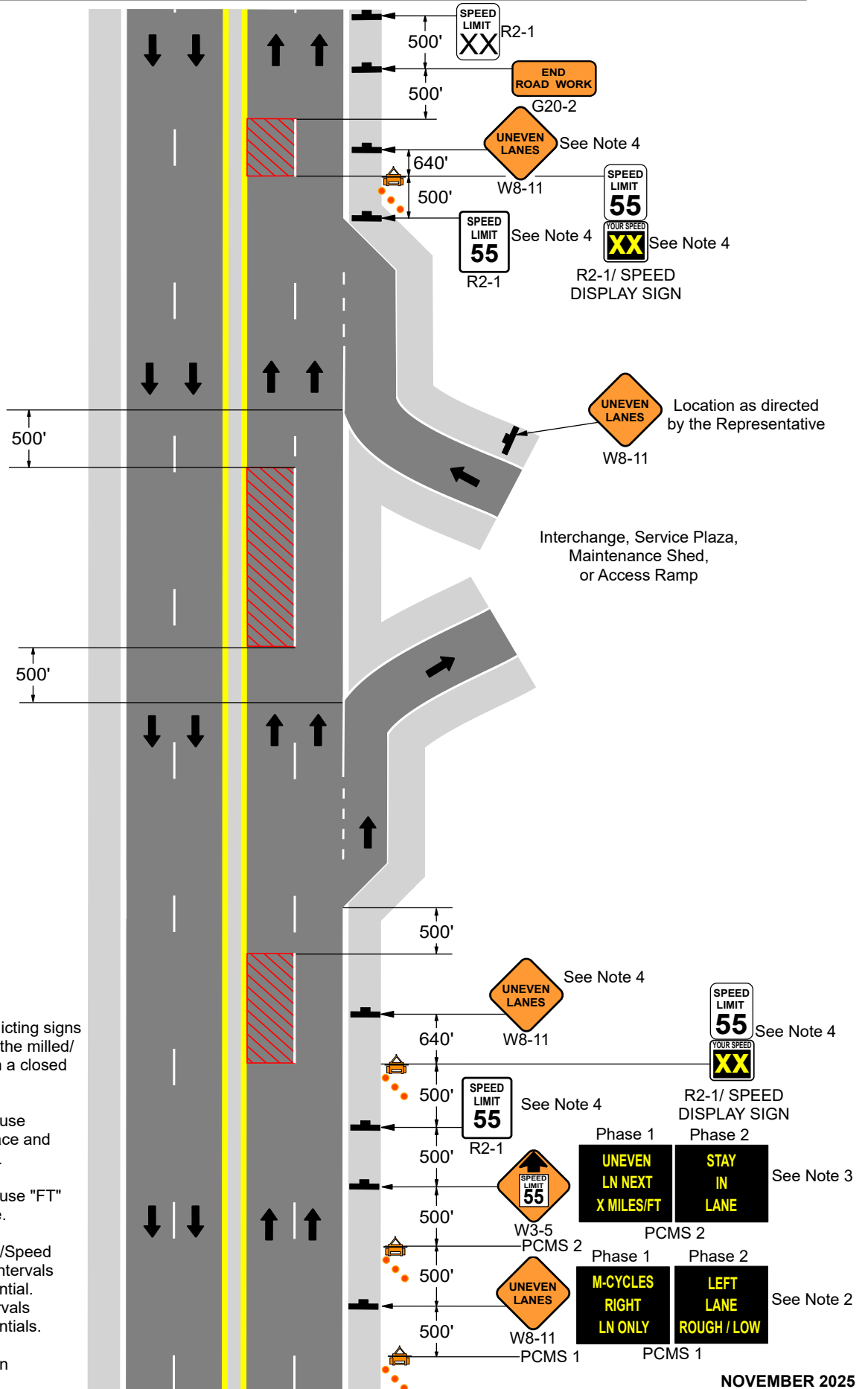

NOTES:

1. Completely cover conflicting signs and turn off PCMS when the milled/ binder pavement is within a closed lane.

2. For PCMS 1 Phase 2, use "ROUGH" for milled surface and "LOW" for binder surface.

3. For PCMS 2 Phase 1, use "FT" if distance is under 1 Mile.

4. Place W8-11 and R2-1/Speed Display Sign at 1/2 mile intervals through pavement differential. Place R2-1 at 1 mile intervals through pavement differentials.

5. See Appendix A for sign descriptions and sizes.

PTS 002A Milled or Binder Pavement Differential in Right and Center Lane

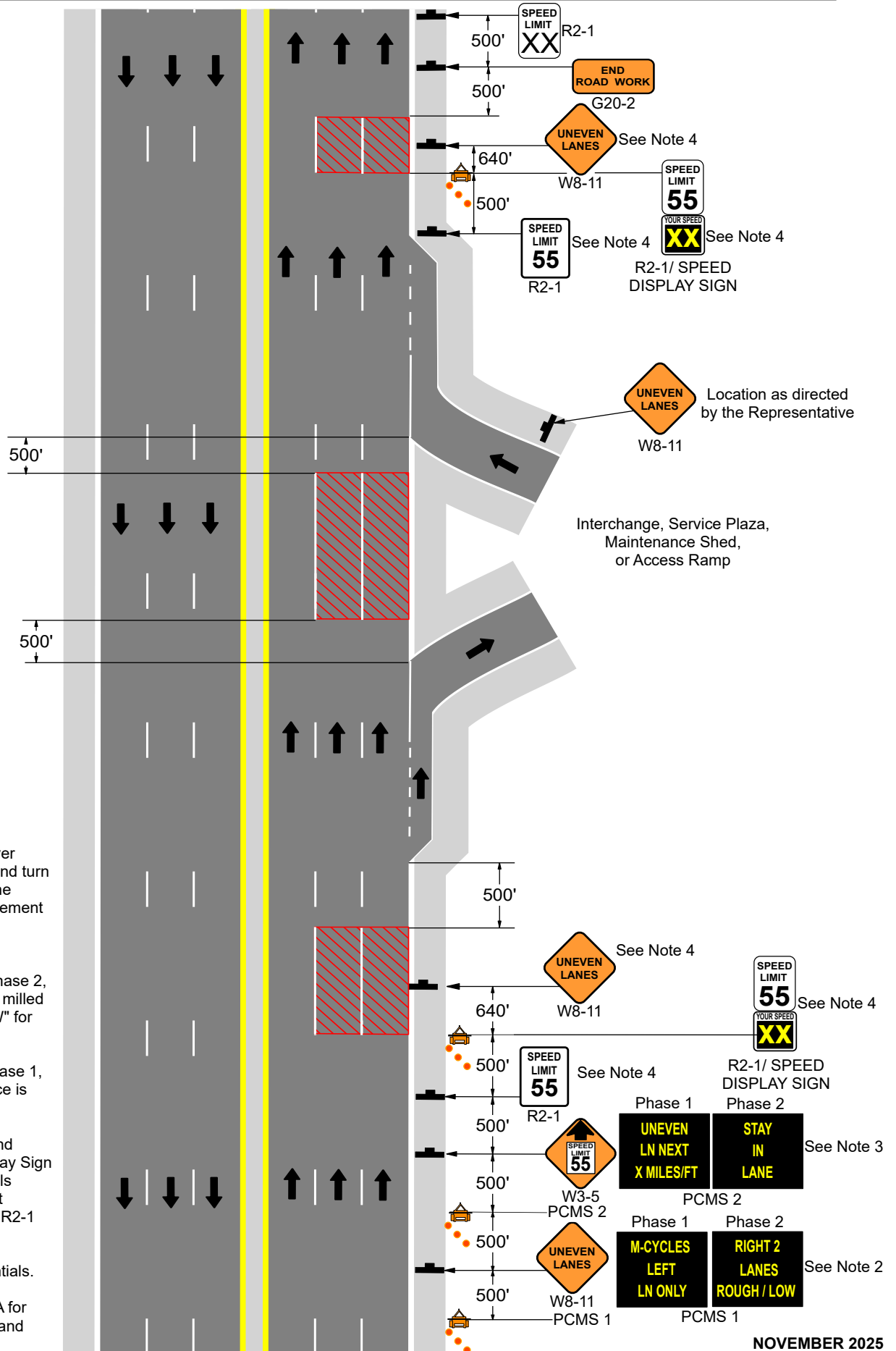

NOTES:

1. Completely cover conflicting signs and turn off PCMS when the milled/ binder pavement is within a closed lane.

2. For PCMS 1 Phase 2, use "ROUGH" for milled surface and "LOW" for binder surface.

3. For PCMS 2 Phase 1, use "FT" if distance is under 1 Mile.

4. Place W8-11 and R2-1/Speed Display Sign at 1/2 mile intervals through pavement differential. Place R2-1 at 1 mile intervals through pavement differentials.

5. See Appendix A for sign descriptions and sizes.

PTS 002B Milled or Binder Pavement Differential in Left and Center Lane

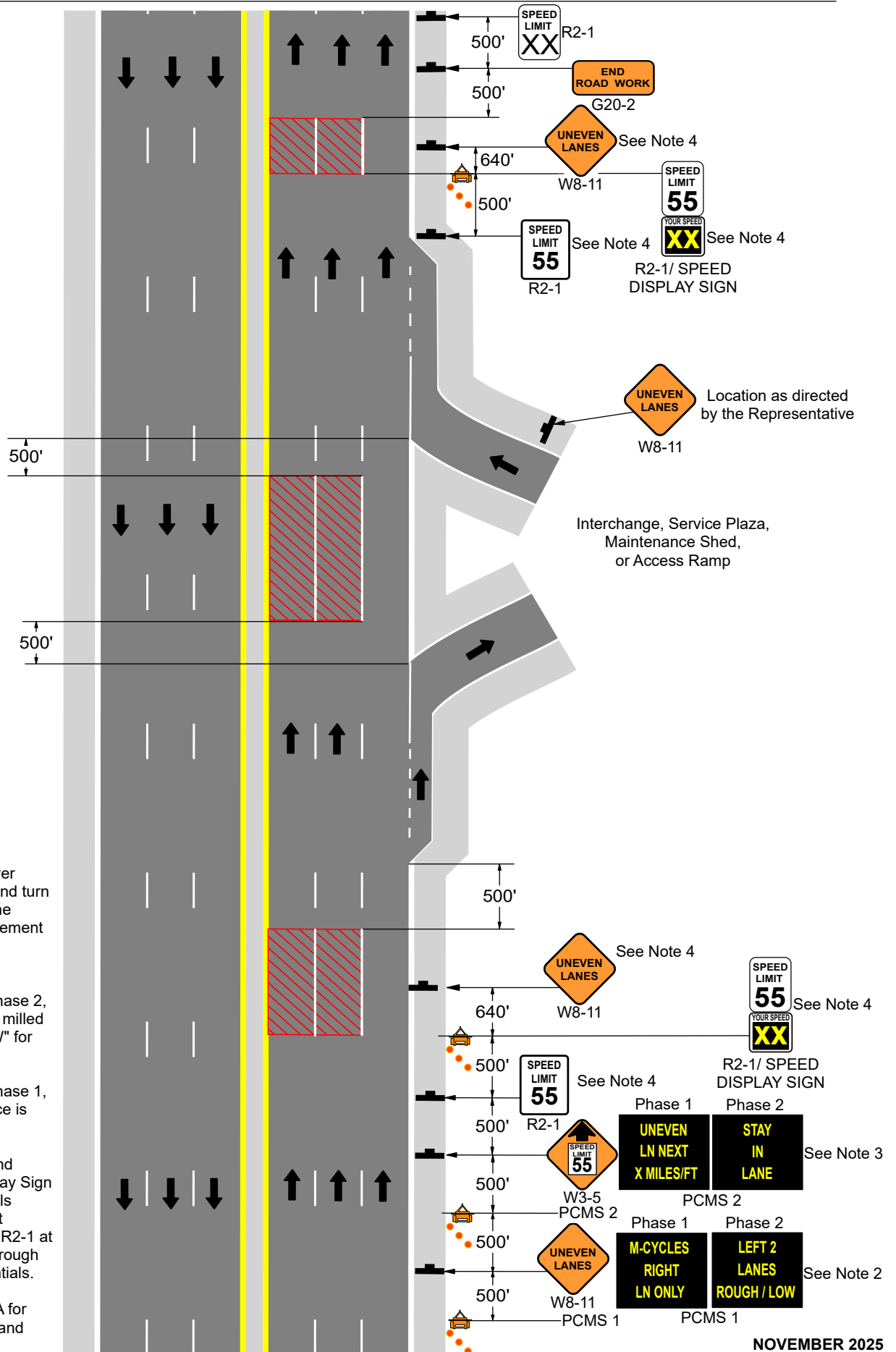

NOTES:

1. Completely cover conflicting signs and turn off PCMS when the milled/ binder pavement is within a closed lane.
2. For PCMS 1 Phase 2, use "ROUGH" for milled surface and "LOW" for binder surface.
3. For PCMS 2 Phase 1, use "FT" if distance is under 1 Mile.
4. Place W8-11 and R2-1/Speed Display Sign at 1/2 mile intervals through pavement differential. Place R2-1 at 1 mile intervals through pavement differentials.
5. See Appendix A for sign descriptions and sizes.

PTS 003 Pavement Differential on Right Shoulder

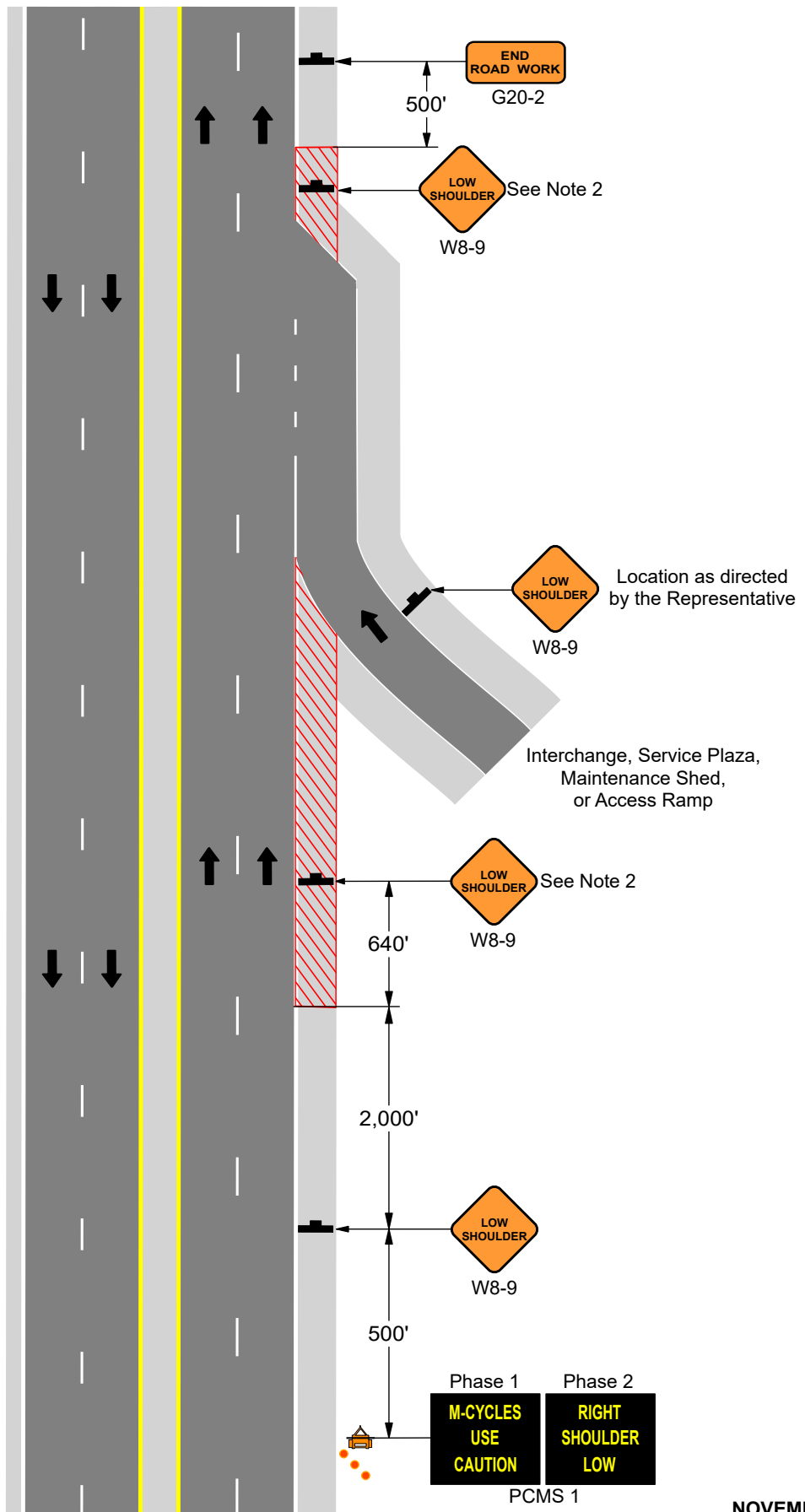

- NOTES:**
1. Completely cover conflicting signs and turn off PCMS when the milled/binder pavement is within a closed lane.
 2. Place W8-9 at 1/2 mile intervals through pavement differential.
 3. See Appendix A for sign descriptions and sizes.

PTS 004 Pavement Differential in Median Shoulder

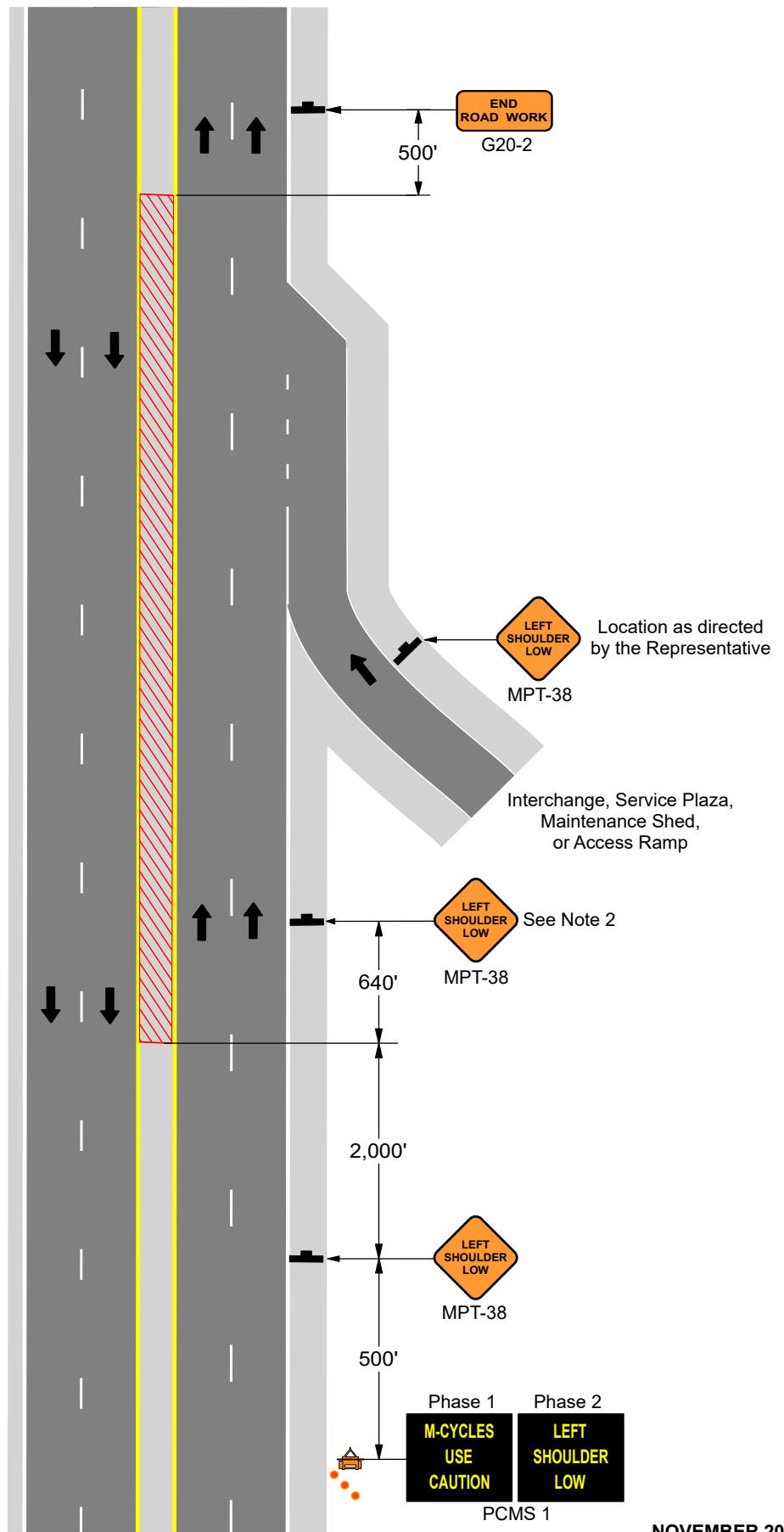

NOTES:

1. Completely cover conflicting signs and turn off PCMS when the milled/binder pavement is within a closed lane.

2. Place MPT-38 at 1/2 mile intervals through pavement differential.

3. See Appendix A for sign descriptions and sizes.

PTS 005 Traffic Control Device Installation Sequence

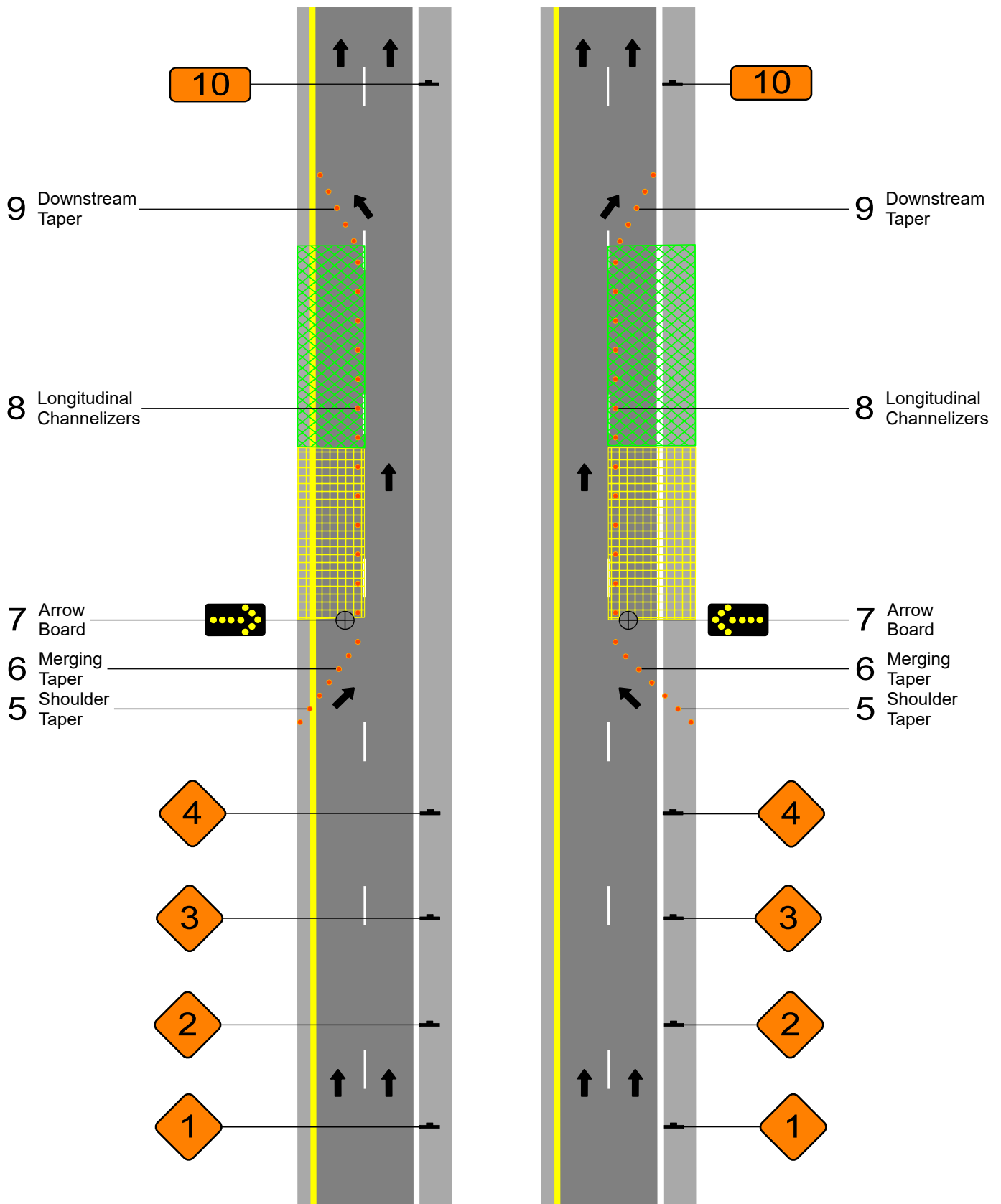

NOTES:
1. Channelizing devices shall be installed in the downstream direction.

PTS 006 Traffic Control Device Removal Sequence

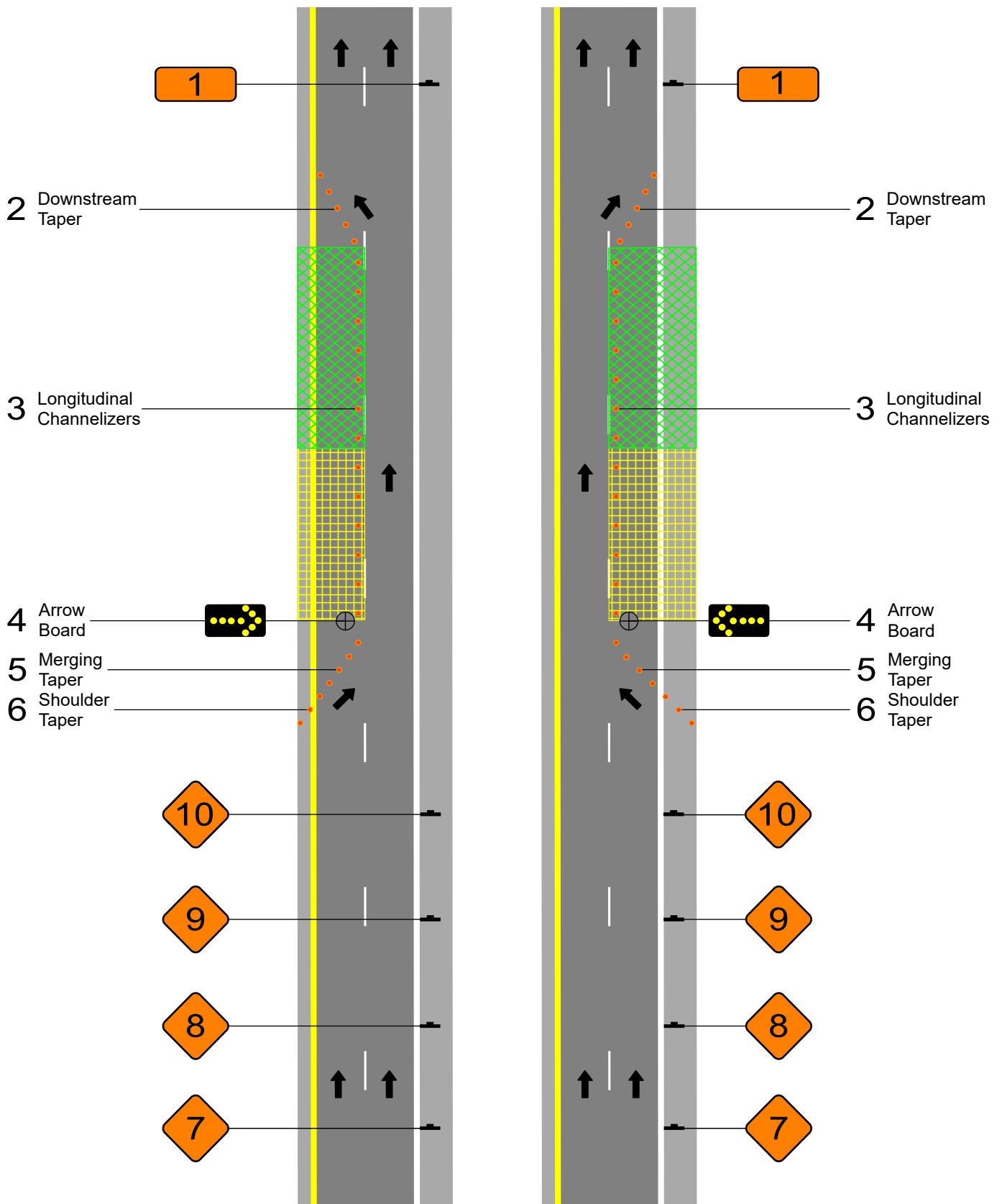

NOTES:
1. Channelizing devices shall be removed in the upstream direction.

PTS 007 - Notes

Trailer-Mounted Equipment Placement and Delineation

1. The Clear Zone as shown in the table below is provided as a quick reference guide of clear zone width (in feet) requirements. It displays the largest width for each speed limit group assuming the highest Design ADT with the least traversable slope. Refer to PennDOT Publication 13M, Design Manual, Part 2, Chapter 12, for more information about clear zones.
2. Delineation with channelizing devices is required for trailer-mounted equipment such as Portable Changeable Message Signs (PCMS), Speed Display Trailers, Portable Cameras, etc. located within the clear zone, and not protected by guide rail or temporary barrier.
3. Place trailers in the safest locations that will provide maximum performance. The trailer hitch shall be on the opposite side of traffic approaching in the nearest lane as shown on the drawings.
4. PCMS shown on drawings; applicable to all trailer-mounted equipment.

Clear Zone Width
(In Feet from Edge of Traveled Way)

Speed Limit (MPH)	Estimated Clear Zone Width (feet)
<55	24
55	26
70	30

PTS 007
Trailer-Mounted Equipment Placement and Delineation

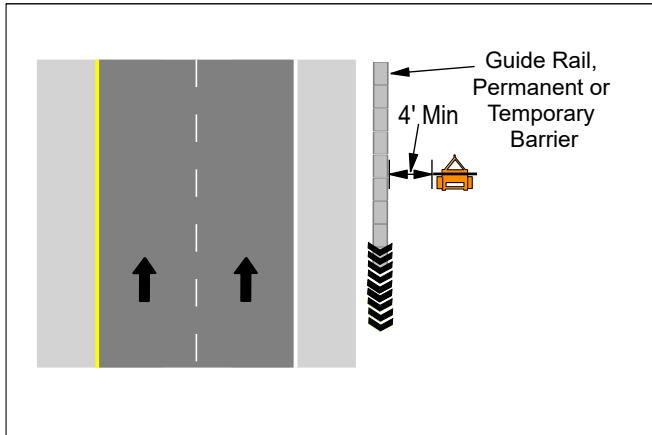

Trailer Behind Guide Rail or Barrier
Delineation is Not Required

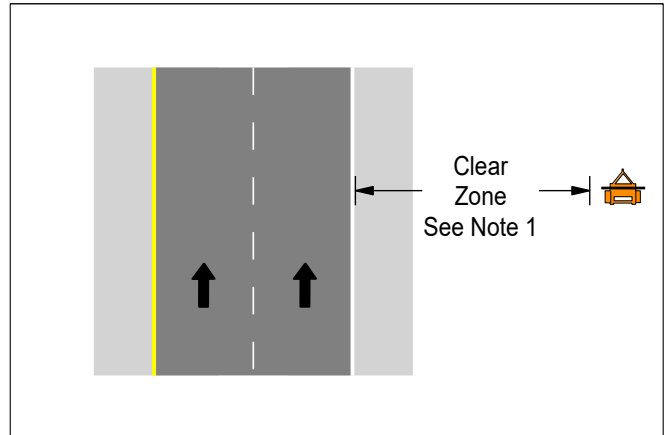

Trailer Outside Clear Zone
Delineation is Not Required

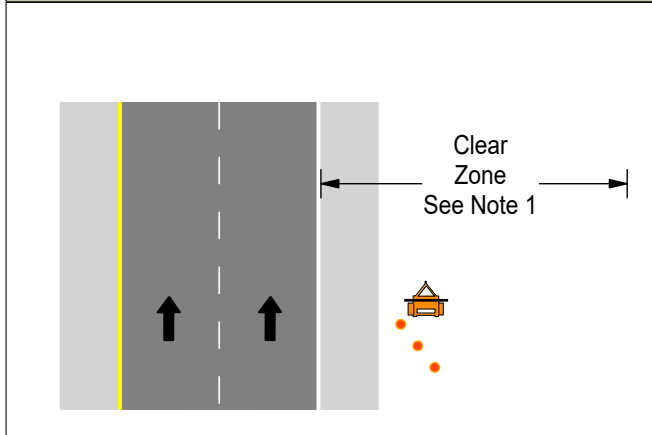

Unprotected Trailer within Clear Zone
Delineation is Required

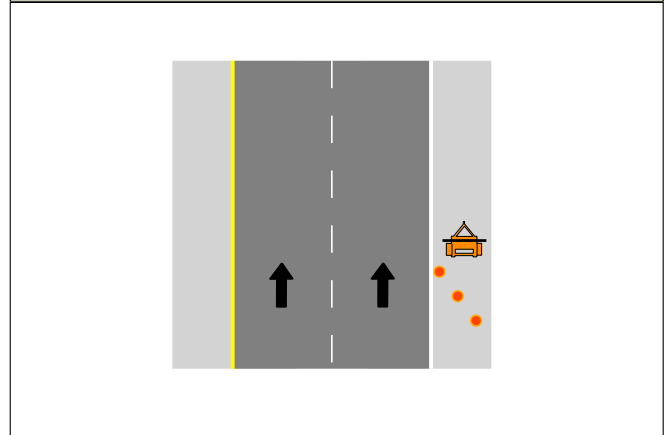

Unprotected Trailer on Shoulder
Delineation is Required

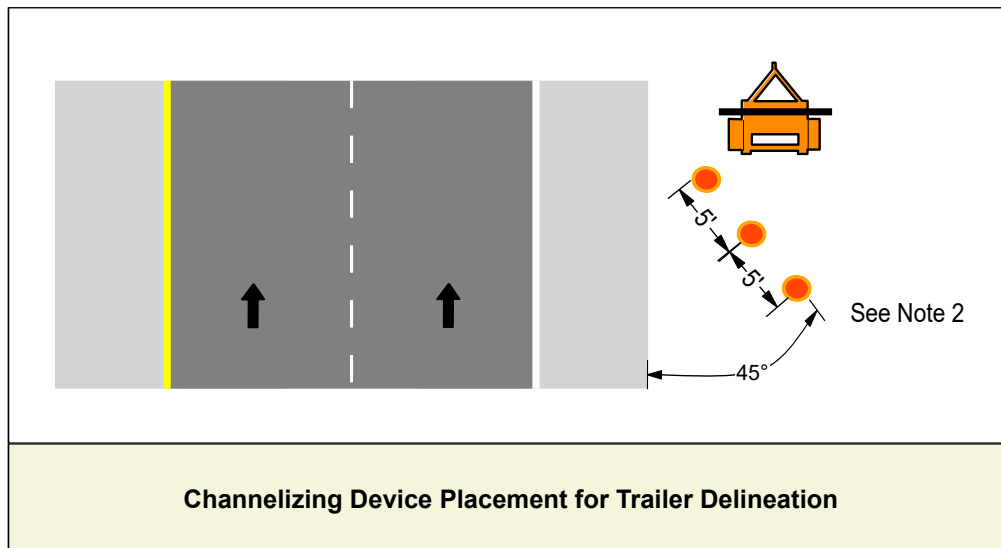

Channelizing Device Placement for Trailer Delineation

PTS 008
Inlet / Junction Box Delineation

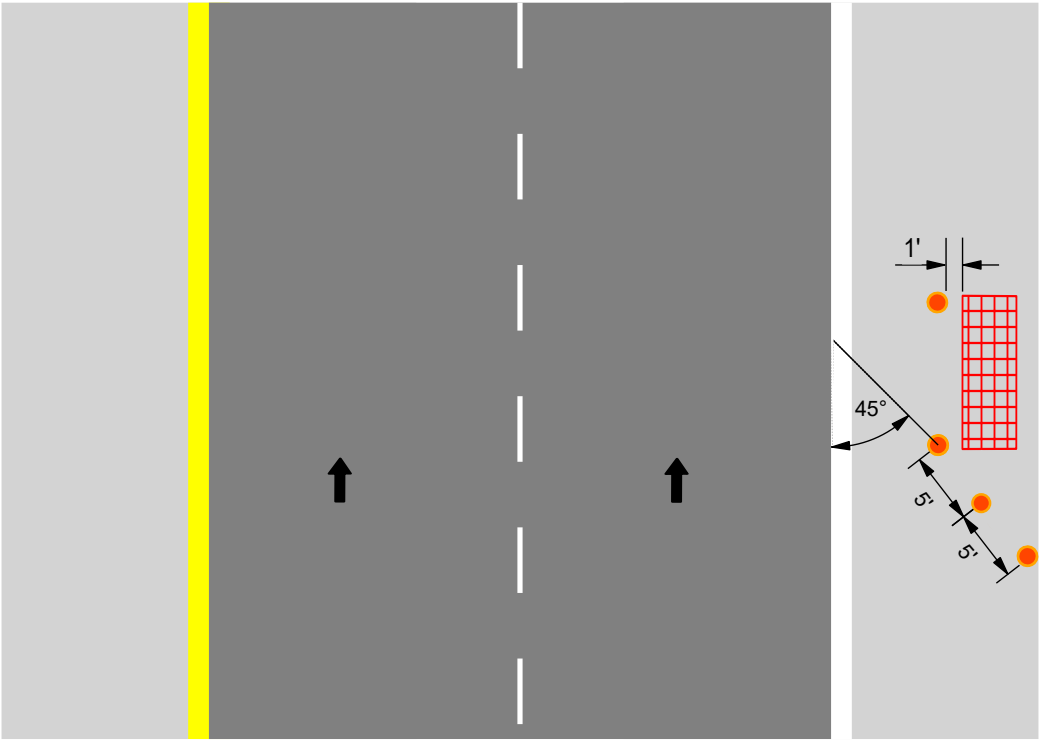

PTS 009
Temporary Impact Attenuator Delineation

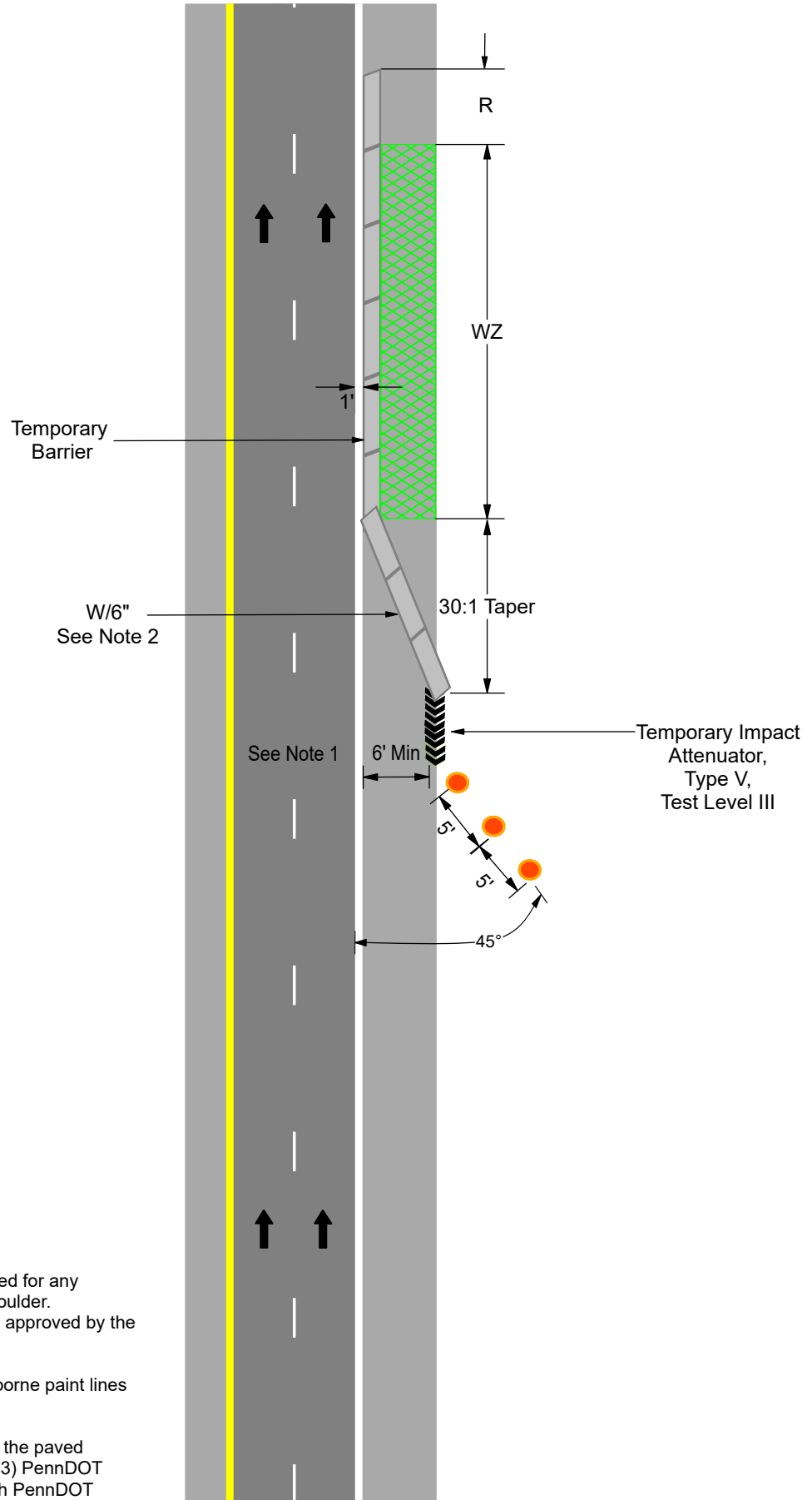

NOTES:

1. Channelizer placement is required for any attenuator placed on the paved shoulder. Any offset less than 6 feet must be approved by the Representative.
2. Provide 6 inch temporary waterborne paint lines the full length of temporary barrier.
3. Delineate attenuators placed on the paved shoulder with a minimum of three (3) PennDOT approved channelizing devices with PennDOT approved Type XI reflectorized material.

PTS 010 - Notes
Two-Lane Traffic Pace / Stoppage

1. If a ramp entrance is between Shadow Vehicle No. 1 and Shadow Vehicles No. 3 and No. 4, install a Portable Changeable Message Sign (PCMS) at the beginning of the acceleration ramp from the interchange or service plaza with the message displaying the same as Shadow Vehicle No. 1. Provide necessary number of shadow vehicles on ramp (shown as Shadow Vehicle No. 2) to completely block ramp and prevent road users from driving between shadow vehicles.
2. A 7,000 lb GVW (Gross Vehicle Weight) or larger pickup truck loaded to weigh a minimum of 5,500 lbs may be used as Shadow Vehicle No. 1.
3. Position Shadow Vehicle No. 1 so that it is visible from behind for a minimum distance of 700 feet.
4. All arrow boards are to be truck-mounted or trailer-mounted and attached to the truck and shall move with the associated shadow vehicle.
5. All queued traffic shall be cleared and any succeeding traffic pace/stoppage shall not occur until traffic flow has returned to normal pre pace/stoppage conditions.

PTS 010 Two-Lane Traffic Pace / Stoppage

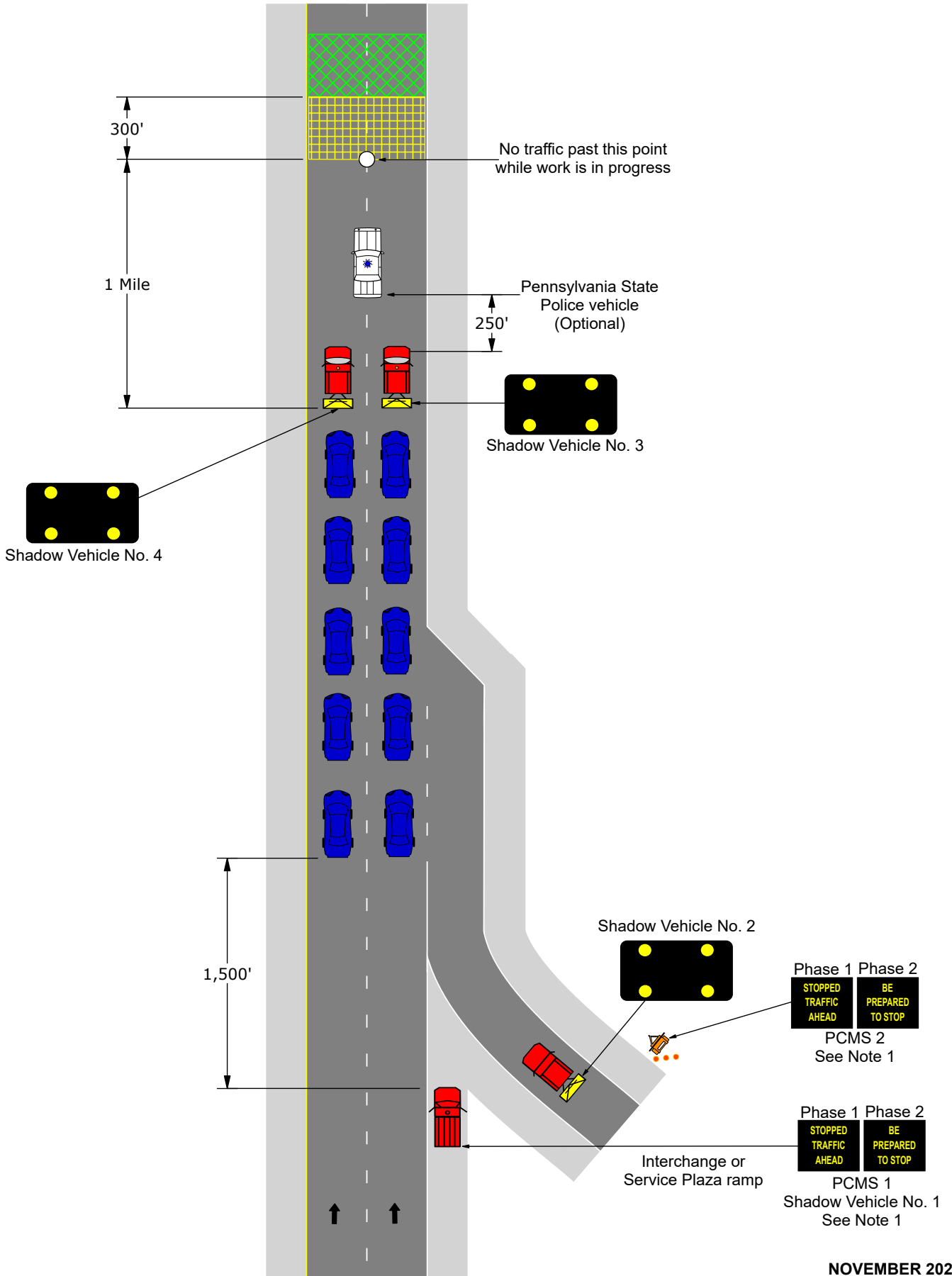

PTS 011 - Notes

Three-Lane Traffic Pace / Stoppage

1. If a ramp entrance is between Shadow Vehicle No. 1 and Shadow Vehicles No. 3, No. 4, and No. 5, install a Portable Changeable Message Sign (PCMS) at the beginning of the acceleration ramp from the interchange or service plaza with the message displaying the same as Shadow Vehicle No. 1. Provide necessary number of shadow vehicles on ramp (shown as Shadow Vehicle No. 2) to completely block ramp and prevent road users from driving between shadow vehicles.
2. A 7,000 lb GVW (Gross Vehicle Weight) or larger pickup truck loaded to weigh a minimum of 5,500 lbs may be used as Shadow Vehicle No. 1.
3. Position Shadow Vehicle No. 1 so that it is visible from behind for a minimum distance of 700 feet.
4. All arrow boards are to be truck-mounted or trailer-mounted and attached to the truck and shall move with the associated shadow vehicle.
5. All queued traffic shall be cleared and any succeeding traffic pace/stoppage shall not occur until traffic flow has returned to normal pre pace/stoppage conditions.

PTS 011 Three-Lane Traffic Pace / Stoppage

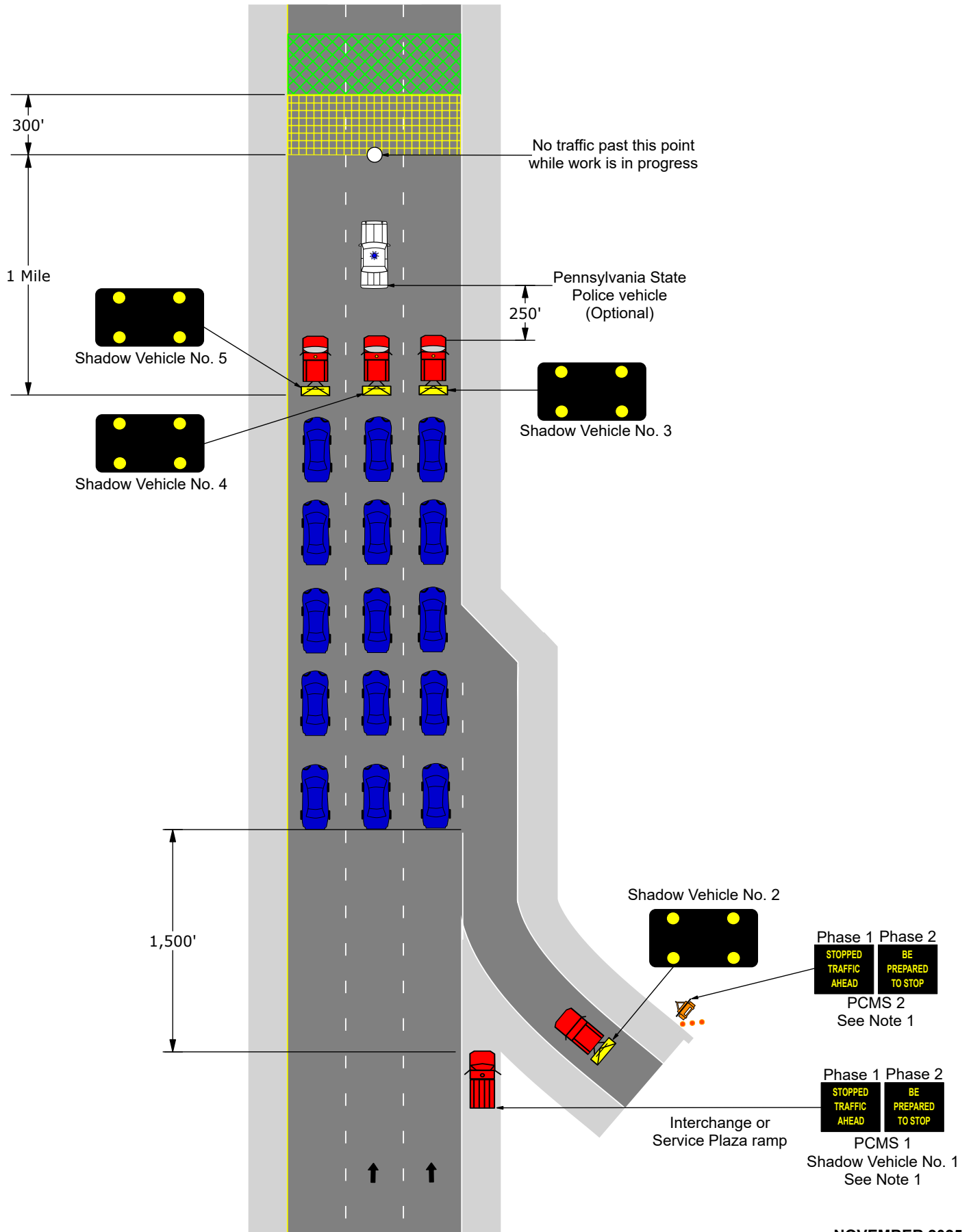

PTS 012
WZSSC Stationary Shoulder Closure with Channelizing Devices

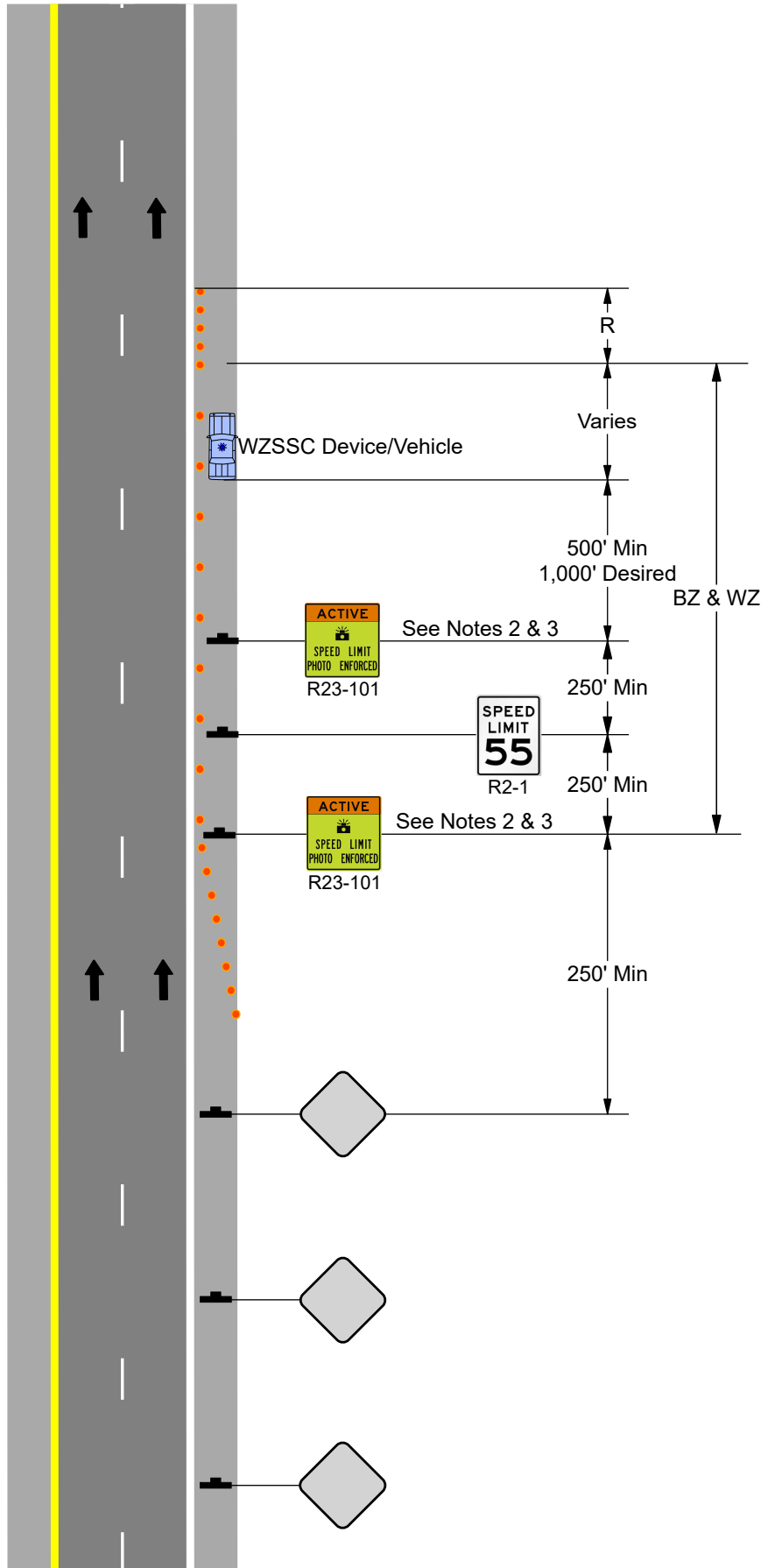

NOTES:

1. This standard is for the positioning and dimensioning of WZSSC unit and signing only. R23-101, R2-1 and WZSSC Device/Vehicle with identifying sign will be furnished, installed, maintained, and removed by WZSSC contracted System Administrator. All other traffic control will be per the appropriate standard.

2. R23-101 sign is not required to be located within the buffer zone or work zone, but minimum distance from WZSSC Device/Vehicle must be maintained.

3. For a left shoulder work zone, use the same sign spacing but with the R23-101 and WZSSC Device/Vehicle located in the closed left shoulder.

4. See Appendix A for sign descriptions and sizes.

PTS 013 WZSSC Lane Closure with Channelizing Devices

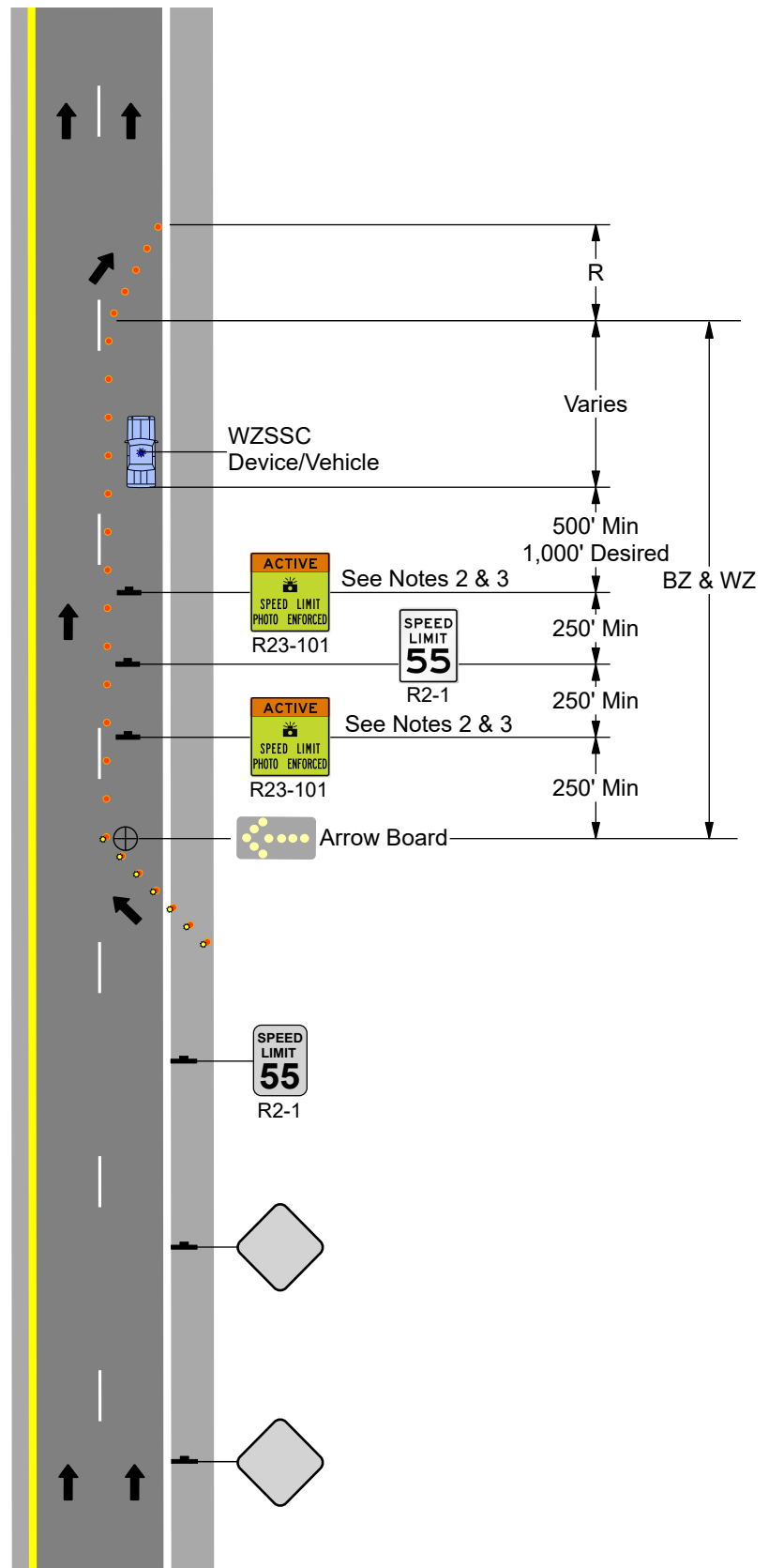

NOTES:

1. This standard is for the positioning and dimensioning of WZSSC unit and signing only. R23-101, R2-1 and WZSSC Device/Vehicle with identifying sign will be furnished, installed, maintained, and removed by WZSSC contracted System Administrator. All other traffic control will be per the appropriate standard.

2. R23-101 sign is not required to be located within the buffer zone or work zone, but minimum distance from WZSSC Device/Vehicle must be maintained.

3. For a left lane work zone, use the same sign spacing but with the R23-101 and WZSSC Device/Vehicle located in the closed left lane.

4. See Appendix A for sign descriptions and sizes.

PTS 014
WZSSC Stationary Shoulder Closure with Temporary Barrier

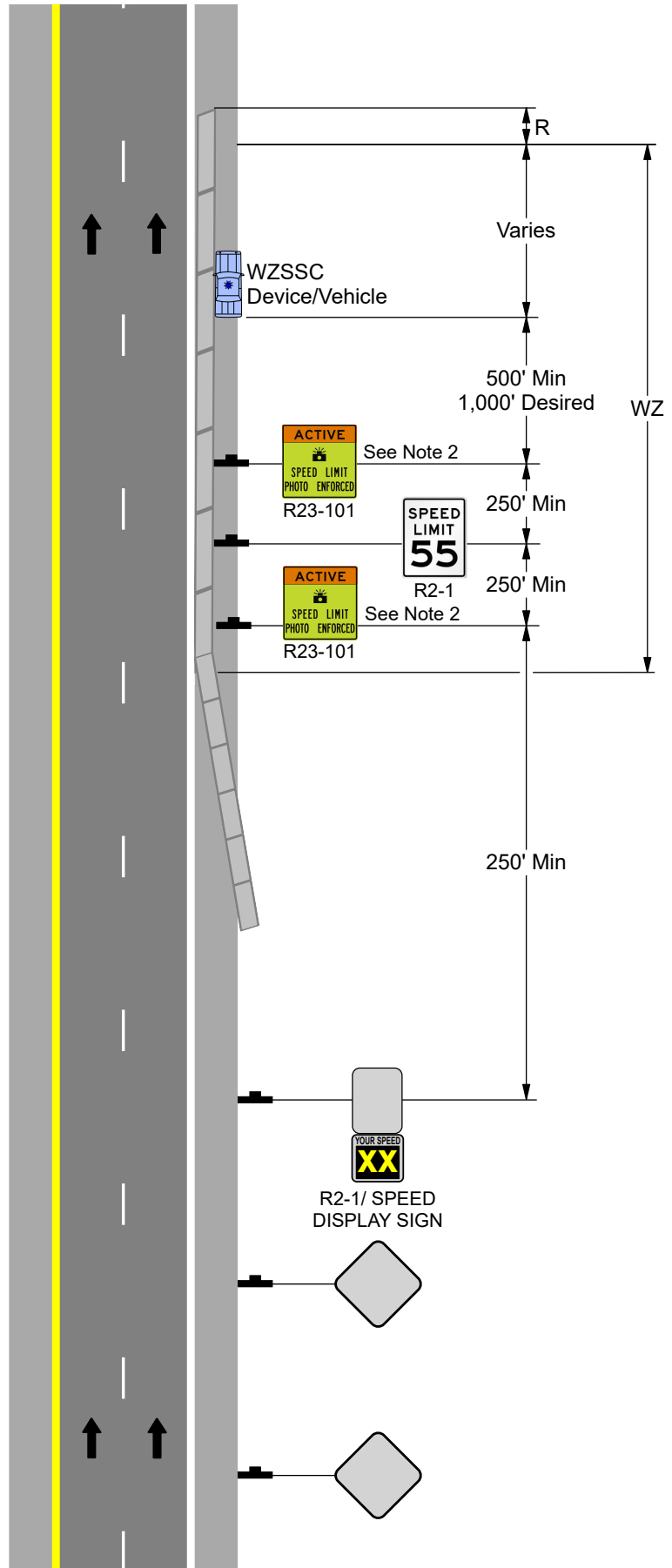

NOTES:

1. This standard is for the positioning and dimensioning of WZSSC unit and signing only. R23-101, R2-1 and WZSSC Device/Vehicle with identifying sign will be furnished, installed, maintained, and removed by WZSSC contracted System Administrator. All other traffic control will be per the appropriate standard.
2. R23-101 sign is not required to be located within the buffer zone, but minimum distance from WZSSC Device/Vehicle must be maintained.
3. This standard shall only be used if the length of the physical work zone is greater than 1 mile.
4. See Appendix A for sign descriptions and sizes.

Standards for Mobile Operations

(PTS 910 Series)

PTS 910-1 - Notes General Notes

1. Use only for mobile operations.
2. Details for the signs and devices can be found in these drawings, PennDOT Publication 236, PennDOT Publication 212 and are to be manufactured by a Department of Transportation approved manufacturer as listed in PennDOT Publication 35 (Bulletin 15).
3. Use PennDOT approved Type XI reflectorized material for signs.
4. These standards are not intended to relieve the Contractor of the responsibility for the protection of the traveling public and construction personnel. Standards specified in Section 901.3(a) are minimum and additional measures may be needed if problems are encountered during the term of the contract.

PTS 910-2 - Notes

Mobile Shoulder Operations

1. This figure applies when separating approaching drivers from an operation that will be moving continuously or intermittently at an average speed of more than 1 MPH (88 FT./MIN.) where the vehicle will not be stopped at any single location for more than fifteen (15) minutes. The operator is to be the only occupant of Shadow Vehicle No. 1. If these conditions cannot be met, use Stationary Shoulder Closure with Channelizing Devices as shown on PTS 920-2 or use Single Lane Closure with Channelizing Devices, as shown on PTS 920-3.

2. All arrow boards are to be truck-mounted or trailer-mounted and attached to the truck and shall move with the associated shadow vehicle.

3. MPT-34 sign only to be used for mobile shoulder operations. The MPT-34 sign shall not be used for operations that require Shadow Vehicle No. 1 to change from a mobile shoulder operation to a mobile lane operation as shown on PTS 910-3 or PTS 910-4.

4. Mobile shoulder operations will not be permitted when all lanes are required to be available in accordance with the allowable working hours or the specified holiday restrictions.

5. Mobile shoulder operations shall only be used where the shoulder width is a minimum of 12 feet for the entire length of the work area.

Signs



MPT-34

NOTE: See Appendix A for sign descriptions and dimensions.

PTS 910-2 Mobile Shoulder Operations

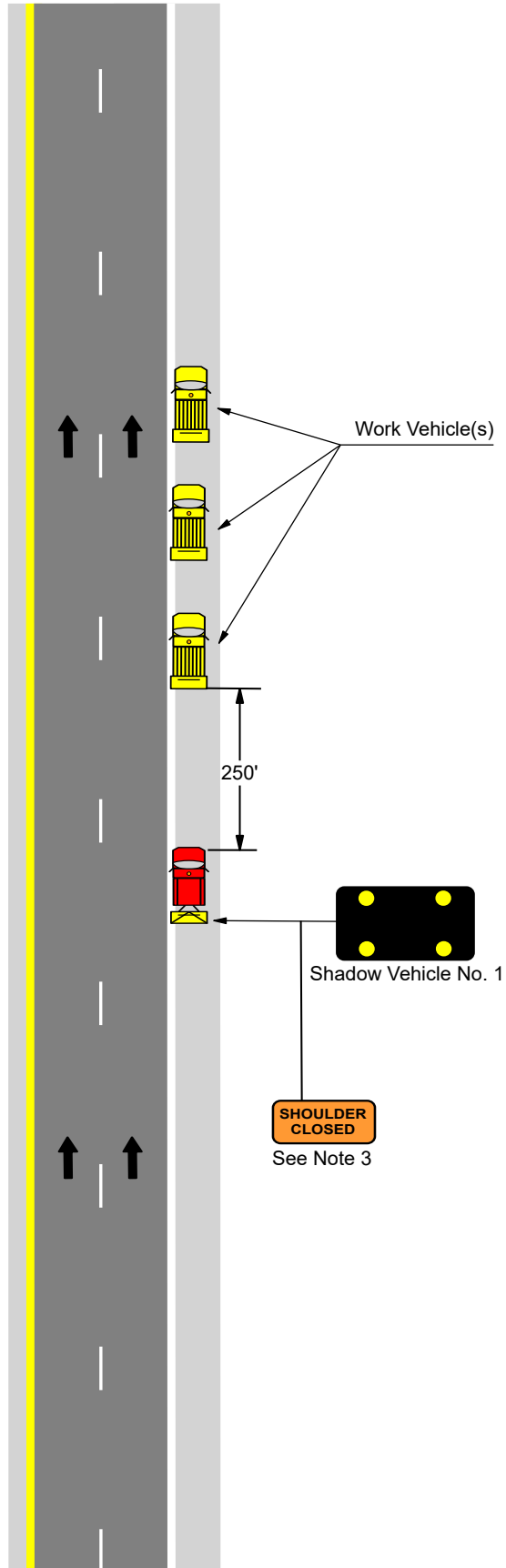

NOTES:
See PTS 910-2 - Notes for applicable notes to this drawing.

See Appendix A for sign descriptions and sizes.

PTS 910-3 - Notes

Mobile Operation for 2 Lanes

1. This figure applies when separating approaching drivers from an operation that will be moving continuously or intermittently at an average speed of more than 1 MPH (88 FT./MIN.) where the vehicle will not be stopped at any single location for more than fifteen (15) minutes. The operator is to be the only occupant of Shadow Vehicle No. 3. If these conditions cannot be met, use a Single Lane Closure with Channelizing Devices Pattern as shown on PTS 920-3.
2. A 7,000 lb GVW (Gross Vehicle Weight) or larger pickup truck loaded to weigh a minimum of 5,500 lbs may be used as Shadow Vehicles No. 1 and 2.
3. Position Shadow Vehicle No. 1 so that it is visible from behind for a minimum distance of 700 feet.
4. All arrow boards and PCMS are to be truck-mounted or trailer-mounted and attached to the truck and shall move with the associated shadow vehicle.
5. The spacing between the work vehicles and the shadow vehicles, and between each shadow vehicle should be minimized to deter road users from driving in between, based on field conditions.
6. Shadow Vehicles No. 1 and 2 may be located on the median shoulder where the median shoulder width is a minimum of 12 feet.
7. Mobile lane operations for 2 lanes will not be permitted when all lanes are required to be available in accordance with the allowable working hours or the specified holiday restrictions.

PTS 910-3A

Mobile Operation for 2 Lanes - Right Lane and Shoulder Work Zone

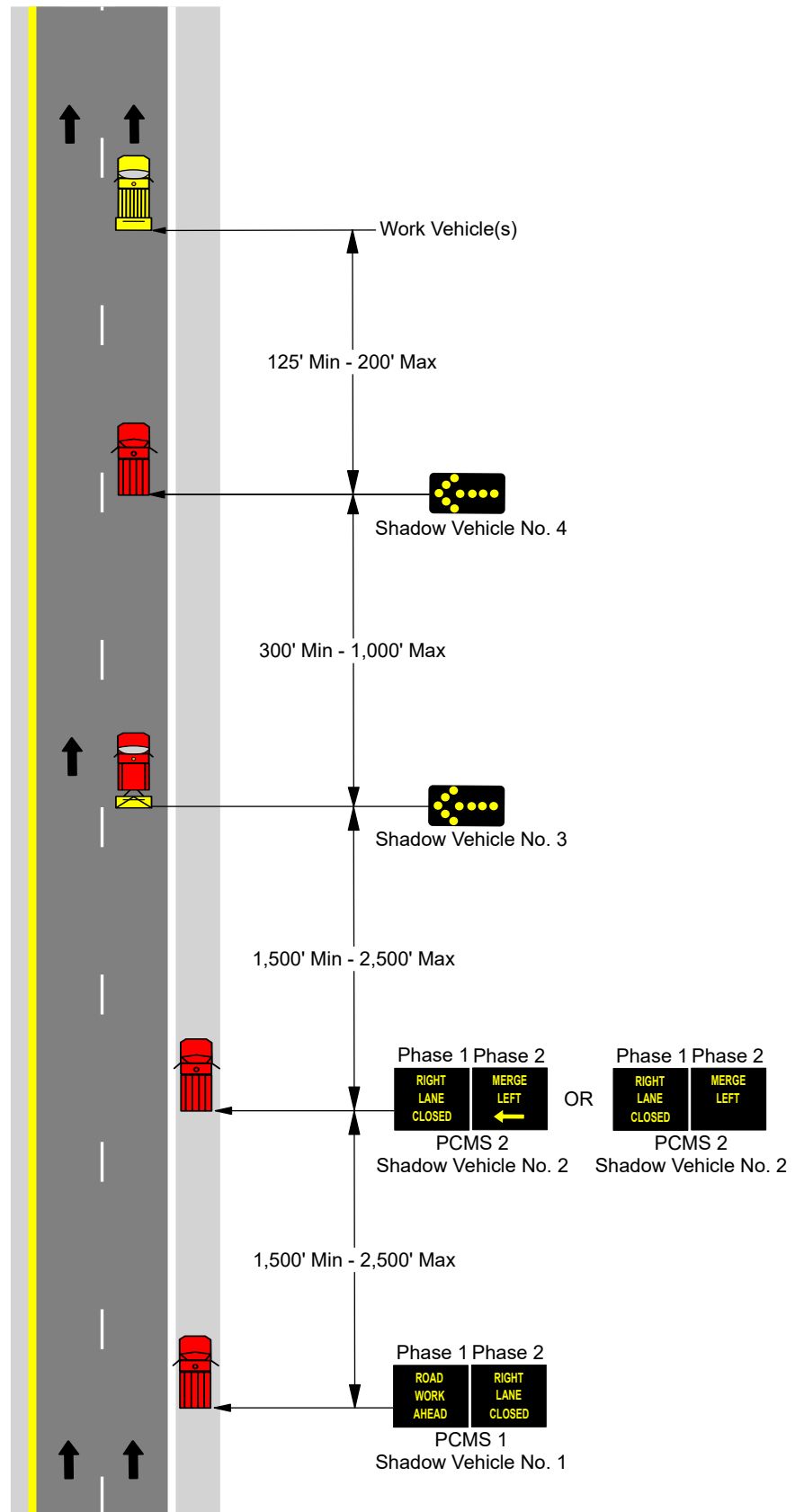

NOTE:
See PTS 910-3 - Notes for
applicable notes to this drawing.

PTS 910-3B

Mobile Operation for 2 Lanes - Left Lane and Median Work Zone

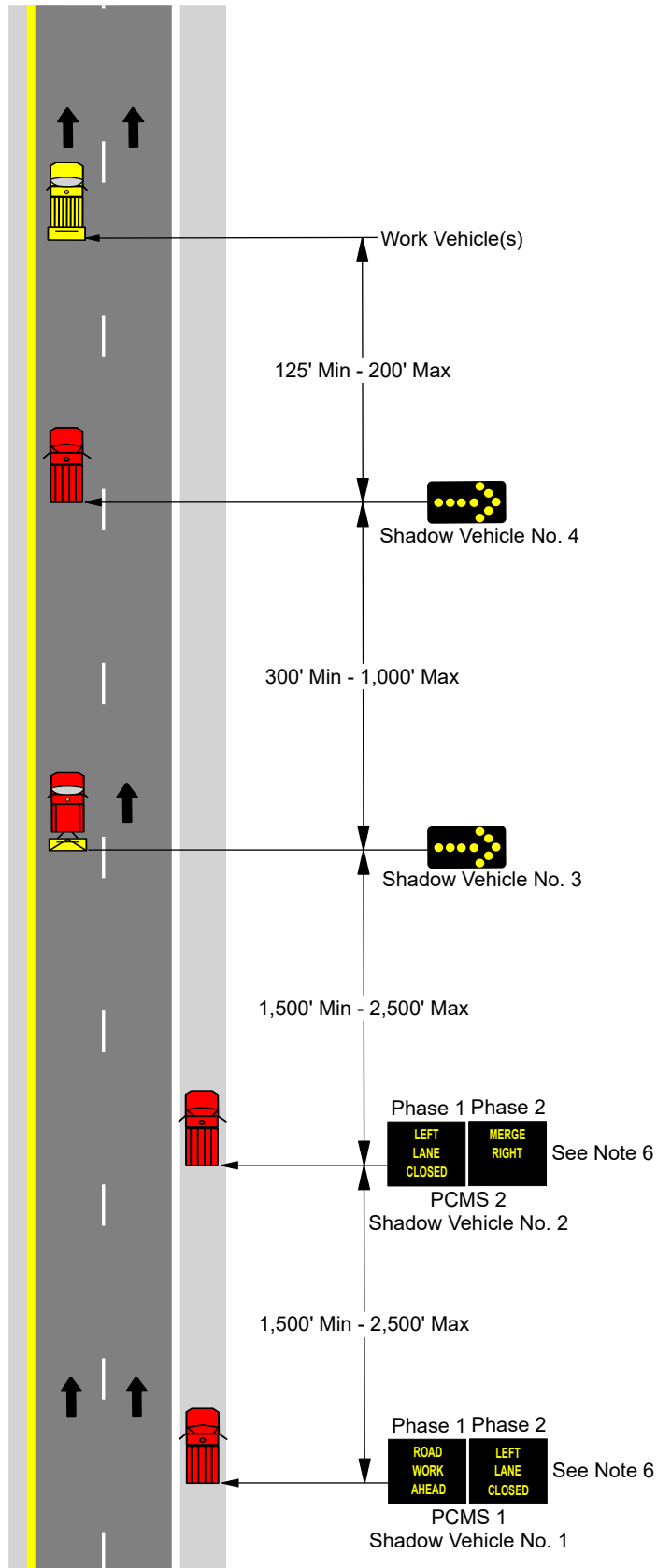

NOTE:
See PTS 910-3 - Notes for
applicable notes to this drawing.

PTS 910-4 - Notes

Mobile Operation for 3 Lanes

1. This figure applies when separating approaching drivers from an operation that will be moving continuously or intermittently at an average speed of more than 1 MPH (88 FT./MIN.) where the vehicle will not be stopped at any single location for more than fifteen (15) minutes. The operator is to be the only occupant of Shadow Vehicles No. 3 and 6. If these conditions cannot be met, use a Dual Lane Closure with Channelizing Devices as shown on PTS 920-4.
2. A 7,000 lb GVW (Gross Vehicle Weight) or larger pickup truck loaded to weigh a minimum of 5,500 lbs may be used as Shadow Vehicles No. 1 and 2.
3. Position Shadow Vehicle No. 1 so that it is visible from behind for a minimum distance of 700 feet.
4. All arrow boards and PCMS are to be truck-mounted or trailer-mounted and attached to the truck and shall move with the associated shadow vehicle.
5. The spacing between the work vehicles and the shadow vehicles, and between each shadow vehicle should be minimized to deter road users from driving in between, based on field conditions.
6. Shadow Vehicles No. 1 and 2 may be located on the median shoulder where the median shoulder width is a minimum of 12 feet.
7. Mobile operations for 3 lanes will not be permitted when all lanes are required to be available in accordance with the allowable working hours or the specified holiday restrictions.

PTS 910-4A Mobile Operation for 3 Lanes - Right and Center Lane Work Zone

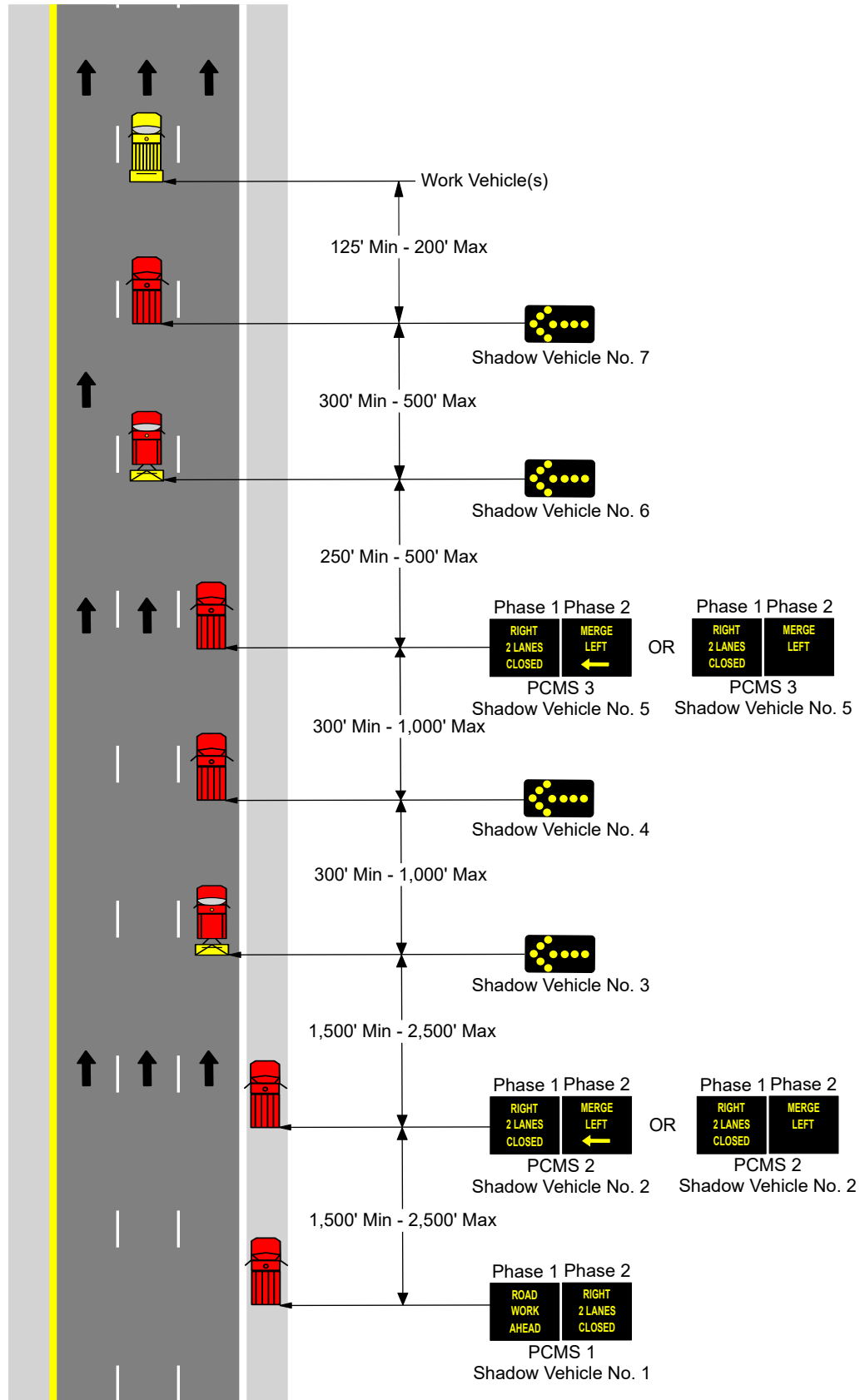

NOTE:
See PTS 910-4 - Notes for applicable notes to this drawing.

PTS 910-4B Mobile Operation for 3 Lanes - Left and Center Lane Work Zone

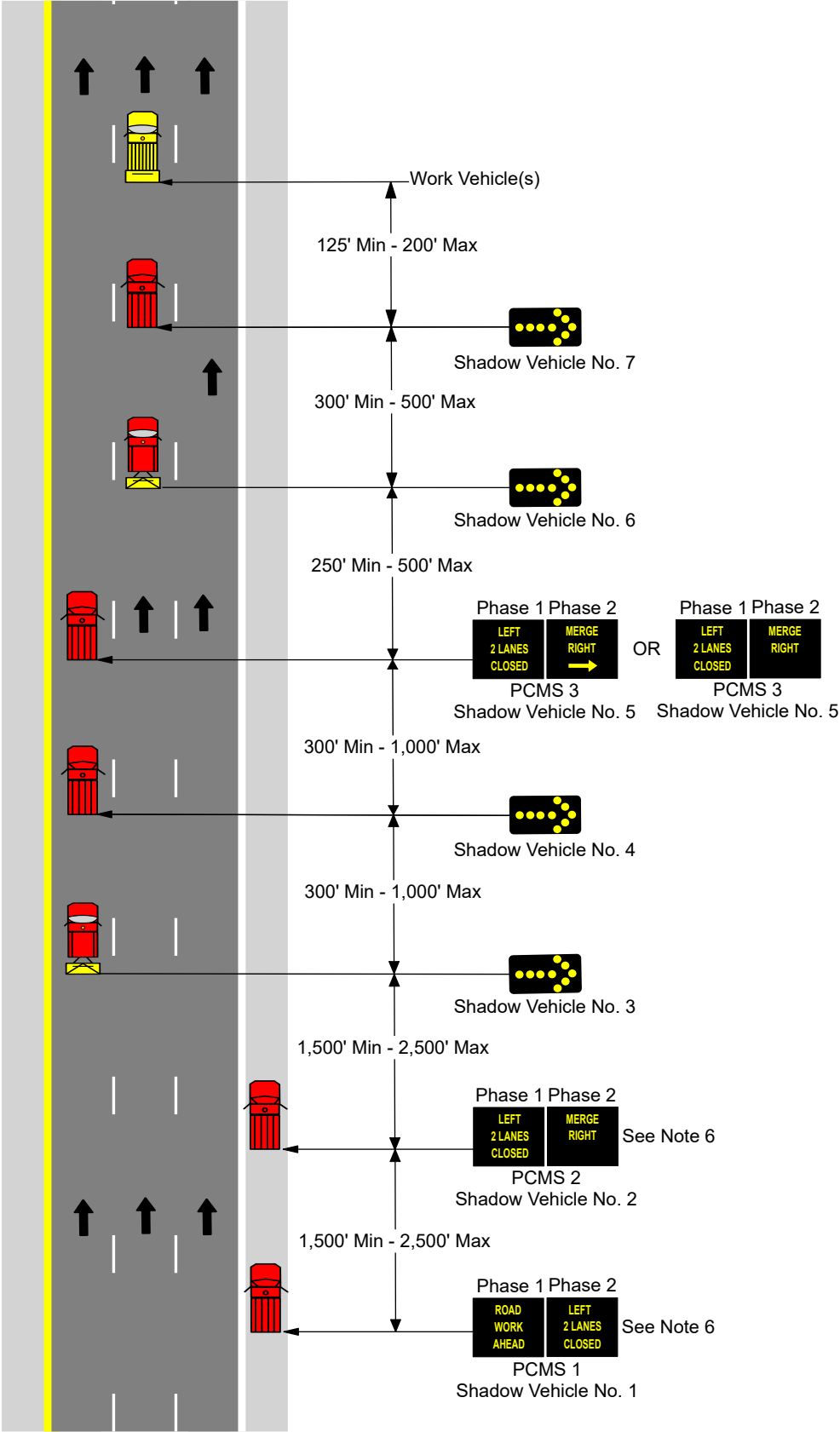

NOTE:
See PTS 910-4 - Notes for applicable notes to this drawing.

PTS 910-5 - Notes

Traffic Line Painting Operation for 2 Lanes

1. This figure applies when separating approaching drivers from an operation that will be moving continuously or intermittently at an average speed of more than 1 MPH (88 FT./MIN.) where the vehicle will not be stopped at any single location for more than fifteen (15) minutes. The operator is to be the only occupant of Shadow Vehicle No. 3. If these conditions cannot be met, use a Single Lane Closure with Channelizing Devices as shown on PTS 920-3.
2. A 7,000 lb GVW (Gross Vehicle Weight) or larger pickup truck and loaded to weigh a minimum of 5,500 lbs may be used as Shadow Vehicle No. 1 and 2.
3. Position Shadow Vehicle No. 1 so that it is visible from behind for a minimum distance of 700 feet.
4. All arrow boards and PCMS are to be truck-mounted or trailer-mounted and attached to the truck and shall move with the associated shadow vehicle.
5. The spacing between the work vehicles and the shadow vehicles, and between each shadow vehicle should be minimized to deter road users from driving in between, based on field conditions.
6. Shadow Vehicles No. 1 and 2 may be located on the median shoulder where the median shoulder width is a minimum of 12 feet.
7. Shadow Vehicles No. 3, No. 4 and No. 5 must be a single axle or tandem axle dump truck or a stake body truck. Light duty dump and light duty stake bodies are not permitted to be used as Shadow Vehicles No. 3, No. 4, and No. 5.
8. Paint Foreman's vehicle may be located:
 - A. In front of the supply vehicle, or
 - B. Behind the supply vehicle, or
 - C. As a temporary replacement for Shadow Vehicle No. 2.
9. State Police vehicle may be located:
 - A. In front of Shadow Vehicle No. 4, or
 - B. Behind Shadow Vehicle No. 4.
10. All vehicles, with exception of State Police vehicle, are to have an activated amber warning light.
11. If supply vehicle is not used, the distance from Shadow Vehicle No. 5 to Line Painting Machine should be 300 feet minimum to 1,000 feet maximum.
12. Traffic line painting operations for 2 lanes will not be permitted when all lanes are required to be available in accordance with the allowable working hours or the specified holiday restrictions.
13. All shadow vehicles are to have an arrow board or a PCMS.
14. This figure shall be used for projects using surface applied pavement markings, temporary or permanent.

PTS 910-5A Traffic Line Painting Operation for 2 Lanes - Right Lane

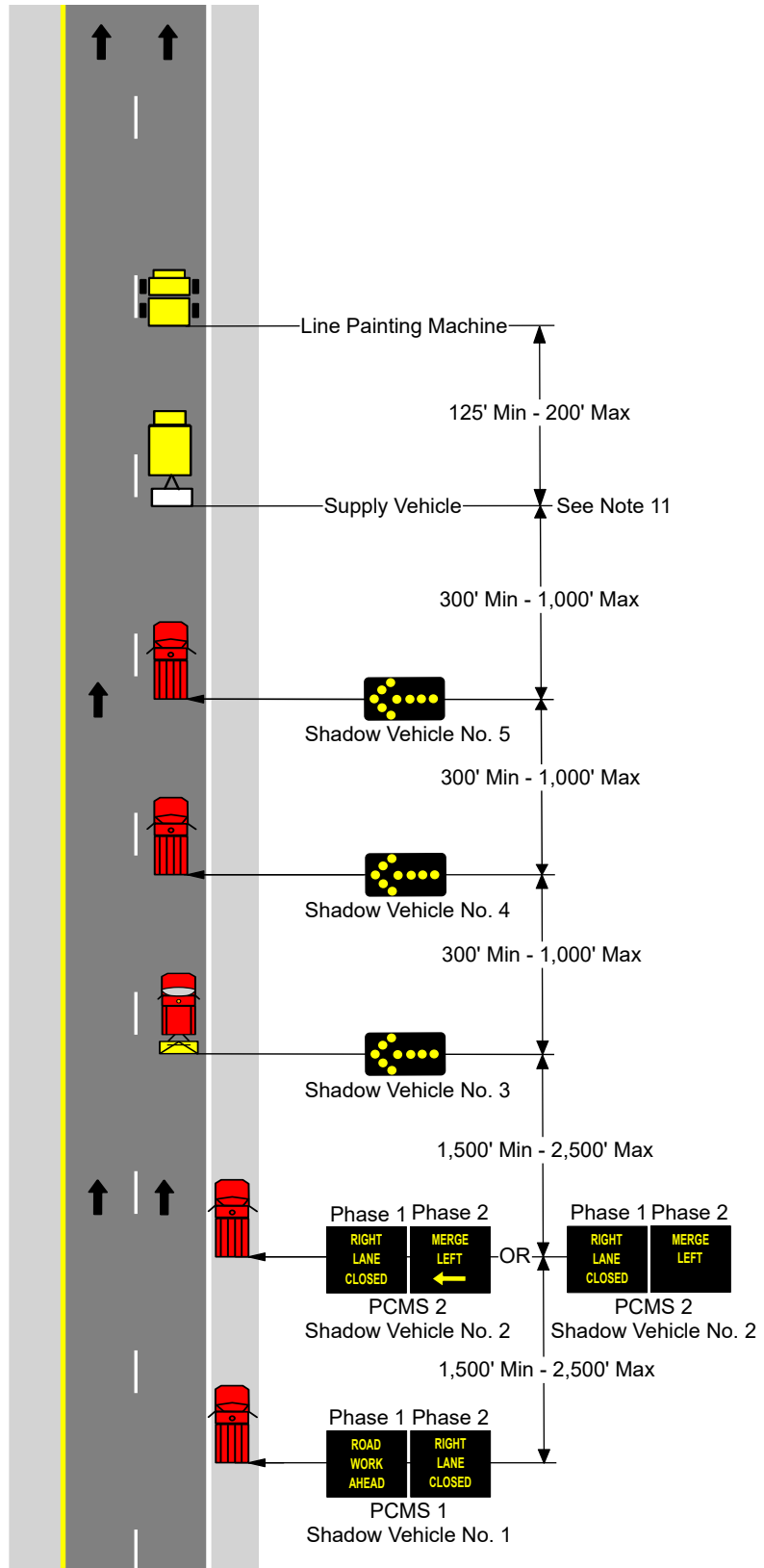

NOTES:
See PTS 910-5 - Notes for applicable notes to this drawing.

PTS 910-5B Traffic Line Painting Operation for 2 Lanes - Left Lane

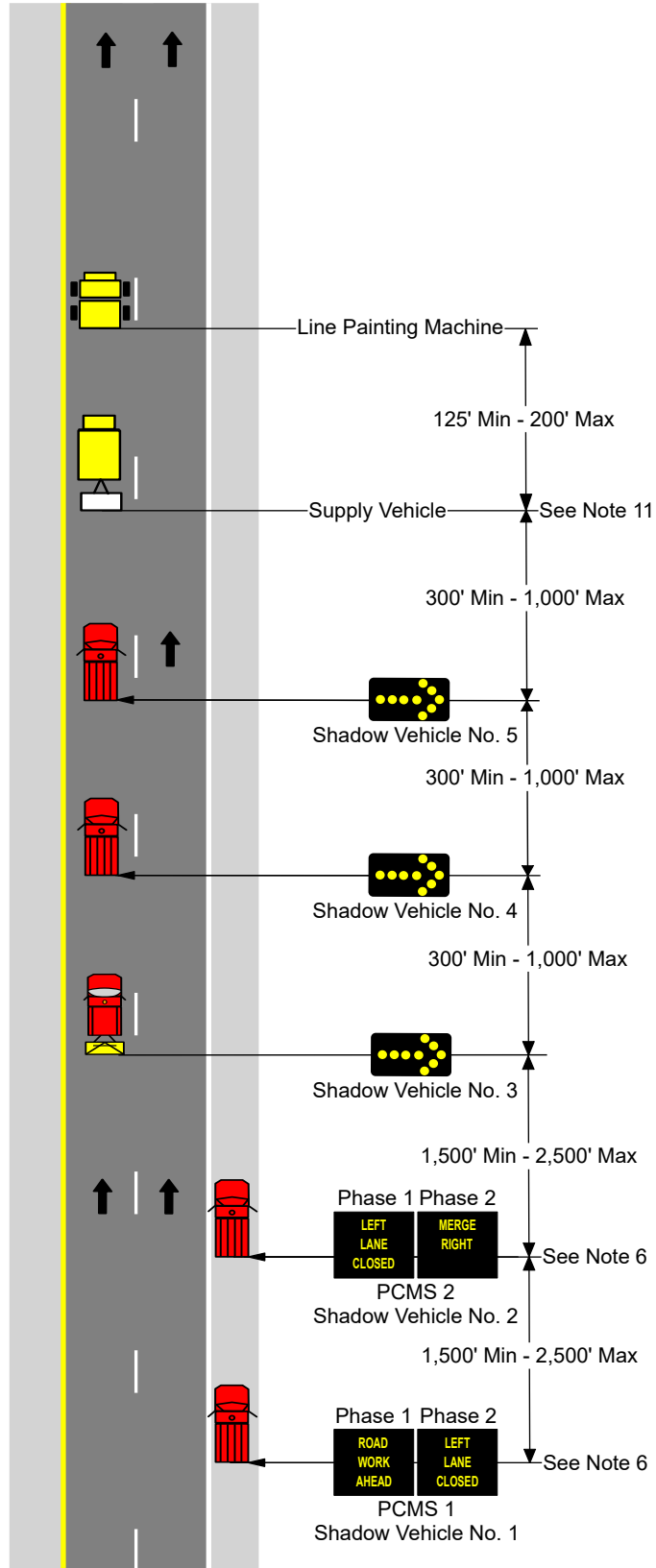

NOTES:
See PTS 910-5 - Notes for applicable notes to this drawing.

PTS 910-6 - Notes

Traffic Line Painting Operation for 3 Lanes

1. This figure applies when separating approaching drivers from an operation that will be moving continuously or intermittently at an average speed of more than 1 MPH (88 FT./MIN.) where the vehicle will not be stopped at any single location for more than fifteen (15) minutes. The operator is to be the only occupant of Shadow Vehicles No. 3 and 6. If these conditions cannot be met, use a Dual Lane Closure with Channelizing Devices as shown on PTS 920-4.
2. A 7,000 lb GVW (Gross Vehicle Weight) or larger pickup truck and loaded to weigh a minimum of 5,500 lbs may be used as Shadow Vehicle No. 1 and 2.
3. Position Shadow Vehicle No. 1 so that it is visible from behind for a minimum distance of 700 feet.
4. All arrow boards and PCMS are to be truck-mounted or trailer-mounted and attached to the truck and shall move with the associated shadow vehicle.
5. The spacing between the work vehicles and the shadow vehicles, and between each shadow vehicle should be minimized to deter road users from driving in between, based on field conditions.
6. Shadow Vehicles No. 1 and 2 may be located on the median shoulder where the median shoulder width is a minimum of 12 feet.
7. Shadow Vehicles No. 3, No. 4, No. 5, No. 6 and No. 7 must be a single axle or tandem axle dump truck or a stake body truck. Light duty dump and light duty stake bodies are not permitted to be used as Shadow Vehicles No. 3, No. 4, No. 5, No. 6 and No. 7.
8. Paint Foreman's vehicle may be located:
 - A. In front of the supply vehicle, or
 - B. Behind the supply vehicle, or
 - C. As a temporary replacement for Shadow Vehicle No. 2.
9. State Police vehicle may be located:
 - A. In front of Shadow Vehicle No. 4 or No. 7, or
 - B. Behind Shadow Vehicle No. 4 or No. 7.
10. All vehicles, with exception of State Police vehicle, are to have an activated amber warning light.
11. If supply vehicle is not used, the distance from Shadow Vehicle No. 7 to Line Painting Machine should be 300 feet minimum to 1,000 feet maximum.
12. Traffic line painting operations for 3 lanes will not be permitted when all lanes are required to be available in accordance with the allowable working hours or the specified holiday restrictions.
13. All shadow vehicles are to have an arrow board or a PCMS.
14. This figure shall be used for projects using surface applied pavement markings, temporary or permanent.

PTS 910-6A

Traffic Line Painting Operation for 3 Lanes - Right and Center Lane

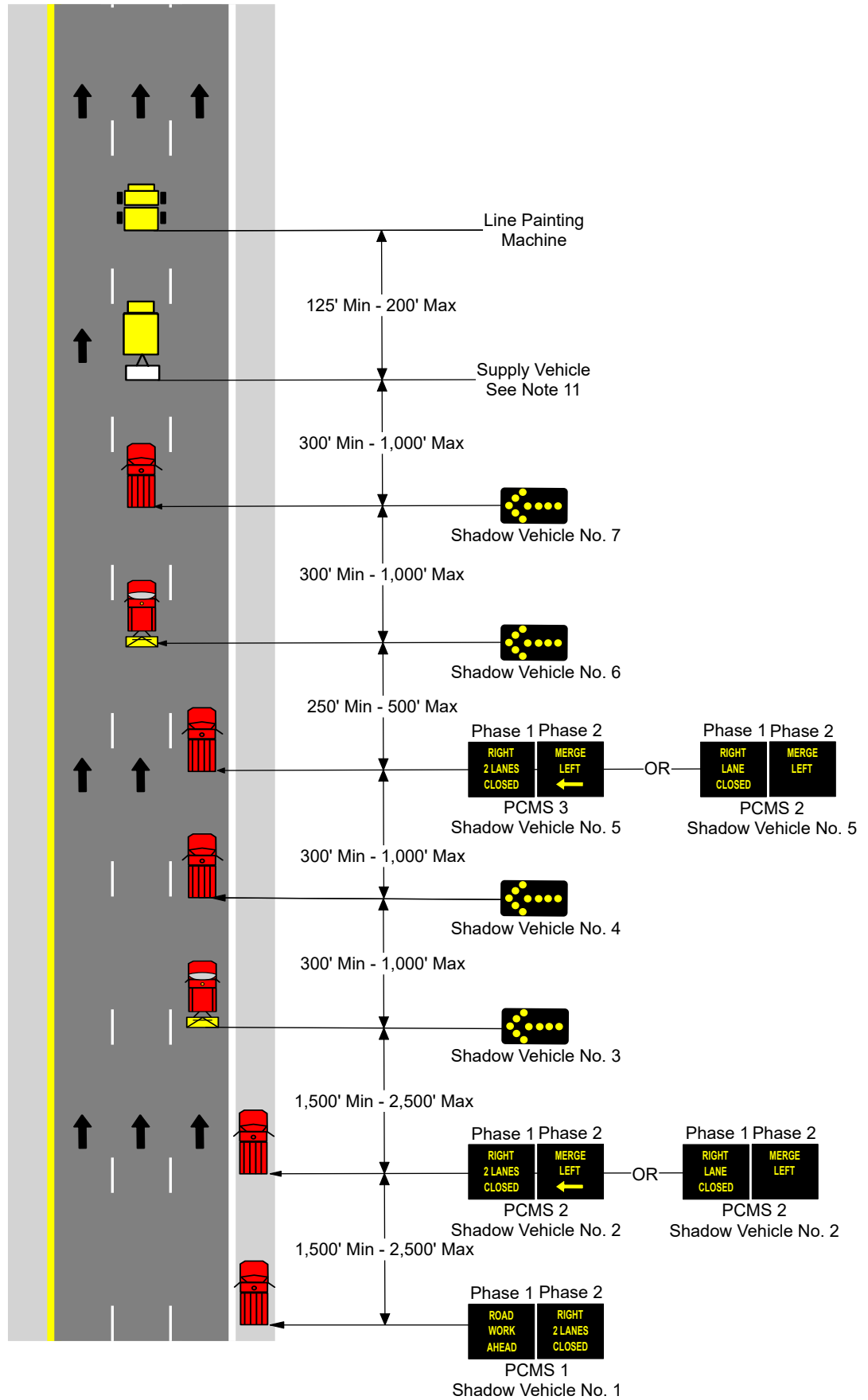

NOTES:
See PTS 910-6 - Notes for applicable notes to this drawing.

PTS 910-6B Traffic Line Painting Operation for 3 Lanes - Left and Center Lane

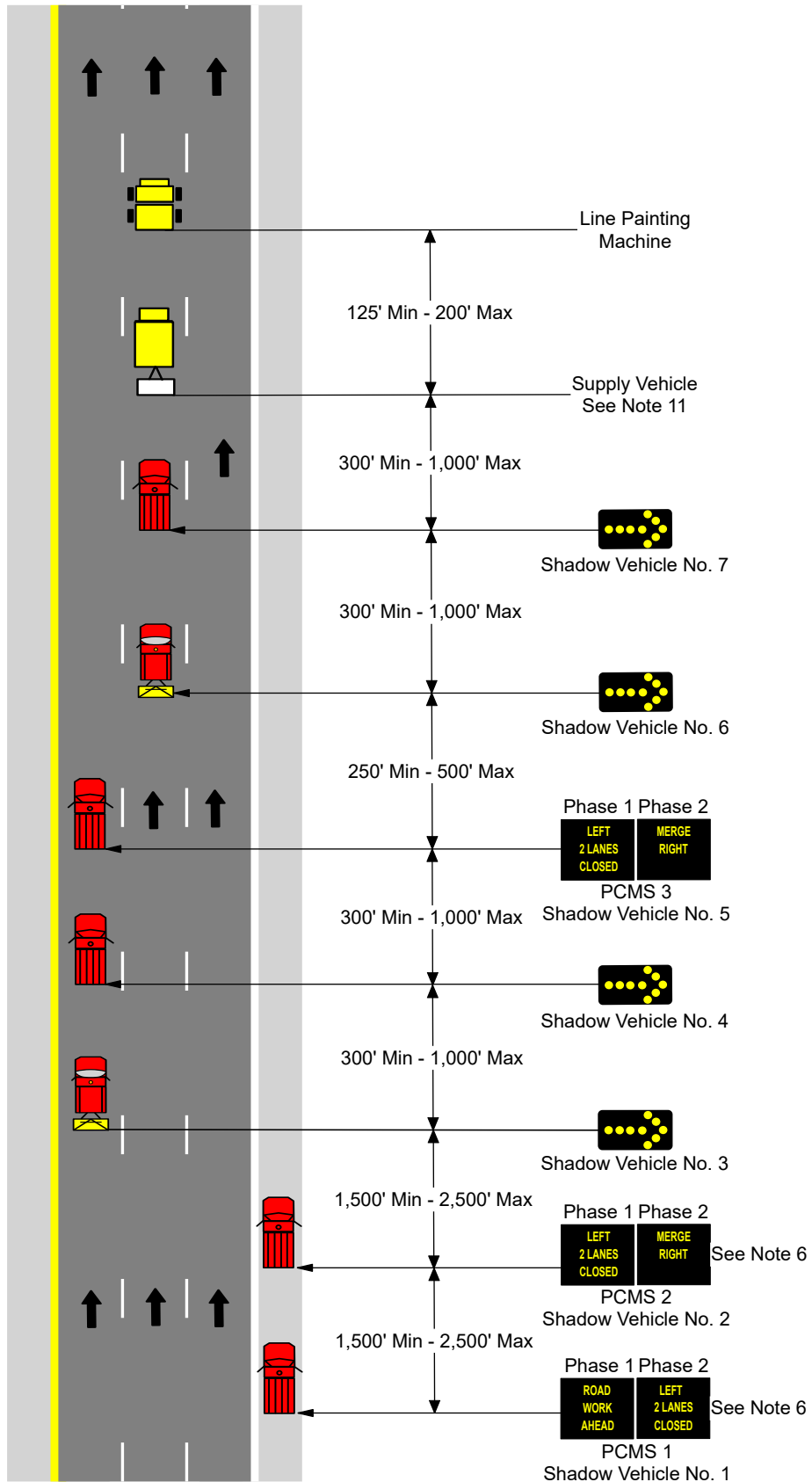

NOTES:
See PTS 910-6 - Notes for applicable notes to this drawing.

PTS 910-7 - Notes

Mowing / Litter Cleanup Operations

1. Vehicles, equipment, material, and workers are not to be located in the buffer zone.
2. All arrow boards are to be truck-mounted or trailer-mounted and attached to the truck and shall move with the associated shadow vehicle.

Signs

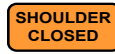

MPT-34

NOTE: See Appendix A for sign descriptions and dimensions.

**PTS 910-7
Mowing / Litter Cleanup Operations**

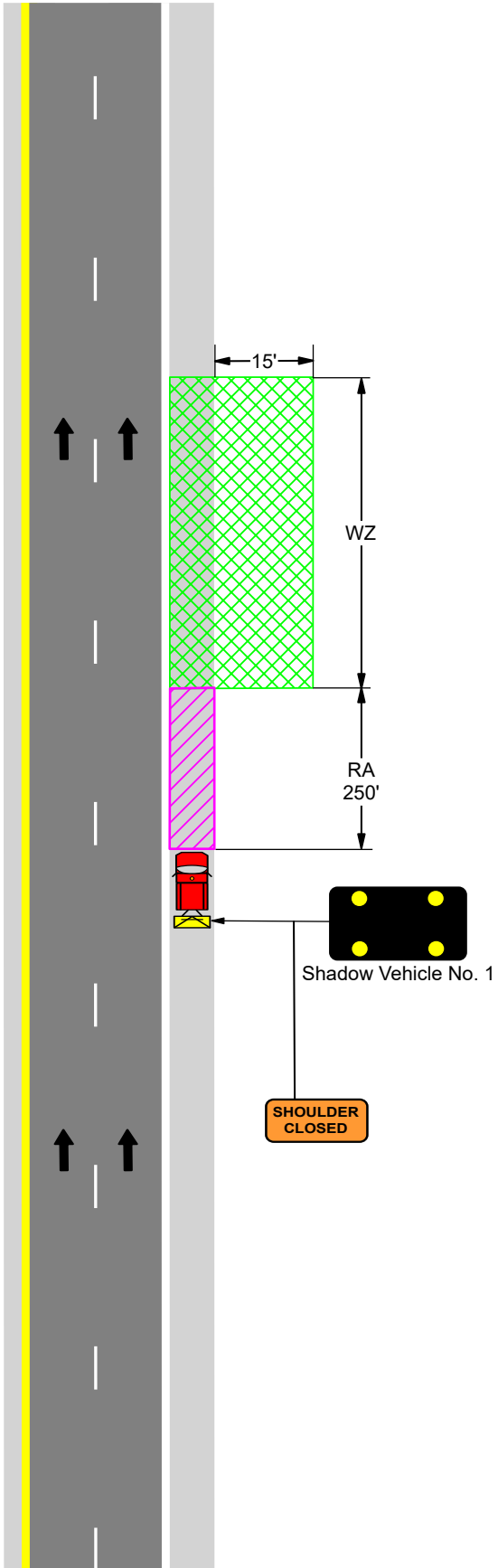

NOTES:
See PTS 910-7 - Notes for applicable notes to this drawing.

See Appendix A for sign descriptions and sizes.

Standards for Short-Term Operations

(PTS 920 Series)

PTS 920-1 - Notes General Notes

1. Use only for short-term operations which occupy a location for less than 12 hours for three (3) or less consecutive days.
2. Remove all traffic control signs and devices immediately upon the completion of the work unless otherwise specified in the special provisions.
3. Place all traffic control devices and have them inspected by the Representative before work begins.
4. Maintain a minimum spacing of 200 feet between all regulatory, warning and destination signs.
5. Provide at minimum a 40 feet width beyond the edge of the travel lane free of obstacles. Drop-offs greater than 2 inches in depth in work zone(s) during non-working hours shall be separated from motorists with temporary barrier per PTS 930. Separation of work zone(s) is incidental to the MPT.
6. Details for the signs and devices can be found in these drawings, PennDOT Publication 236, PennDOT Publication 212 and are to be manufactured by a Department of Transportation approved manufacturer as listed in PennDOT Publication 35 (Bulletin 15).
7. Use PennDOT approved Type XI reflectorized material for signs.
8. These standards are not intended to relieve the Contractor of the responsibility for the protection of the traveling public and construction personnel. Standards specified in Section 901.3(a) are minimum and additional measures may be needed if problems are encountered during the term of the contract.
9. Signs and devices may be adjusted to fit field conditions.
10. Normal posted speed limit signs within advanced signing area prior to any W3-5 sign are to remain uncovered.
11. Cover or remove work zone speed limit signs when all normal lanes and all normal median and shoulder are available for the affected direction(s).
12. Only traffic control devices are permitted within the buffer zone. Do not locate vehicles, equipment, material, or workers in this area.
13. Type B light is to be mounted on the side closest to traffic as shown on PTS 980.
14. Type B yellow flashing lights may be used in conjunction with warning signs, unless otherwise indicated on the drawing.

PTS 920-2 - Notes

Stationary Shoulder Closure with Channelizing Devices

1. Stationary shoulder closure with channelizing devices will not be permitted when all lanes are required to be available in accordance with the allowable working hours or the specified holiday restrictions. Channelizing devices to remain in place until work is completed. Maintain normal lanes of traffic.

2. For median operations where the median shoulder is less than 12 feet wide use Single Lane Closure with Channelizing Devices per PTS 920-3, left lane closed. Single lane closure traffic pattern to remain in place until work is completed.

For left shoulder work zone, use the same spacing, location, and pattern but with the signs indicating a left shoulder closure.

3. Install W3-5 sign only in areas where the normal speed limit is 70 MPH.

4. All arrow boards are to be truck-mounted or trailer-mounted and attached to the truck and shall move with the associated shadow vehicle.

5. Compute the minimum desirable shoulder taper length (1/3L) using the following formula:

$$L = S_N \times W$$

Where L = Minimum desirable merging taper length in feet

W = Width of offset in feet

S_N = Normal speed limit in miles per hour

6. R22-1 and W21-19 signs are not required for PTC Maintenance Department Operations.

7. For multiple stationary shoulder closures with temporary barrier located within 1 mile of each other, install advanced signing prior to the first stationary shoulder closure only, with distance displayed on the MPT-31 sign as the length from the beginning of the first stationary shoulder closure to the end of the last stationary shoulder closure. The G20-2 sign is to be installed after the last stationary shoulder closure.

8. MPT-31 sign shall only be used if the length of the physical work zone is greater than 1 mile.

9. If active work is being performed at multiple locations throughout the physical work zone, consider the use of additional Shadow Vehicles(s) with Truck Mounted Attenuator prior to each work location. These additional vehicles are incidental to MPT.

Signs

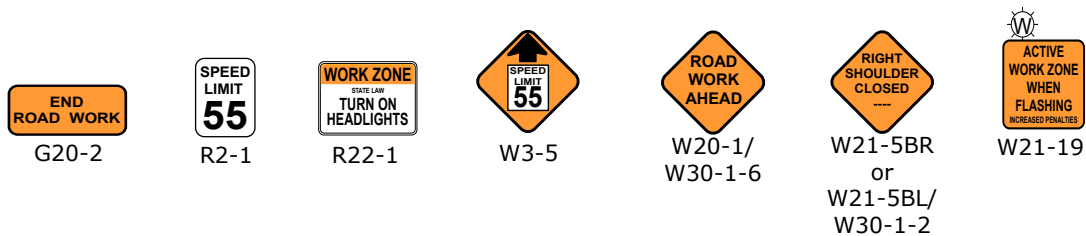

NOTE: See Appendix A for sign descriptions and dimensions.

Distance and Spacing Quick Reference Chart

SPEED	1/3 L	BZ	RA	WZ	R	Maximum Channelizing Device Spacing (Feet)		
						1/3 L	BZ, RA & WZ	R
MPH	Feet	Feet	Feet	Mile(s)	Feet	1/3 L	BZ, RA & WZ	R
55	220	250 (Min)	250	4 (Max)	100	50	100	20
70	280	250 (Min)	250	4 (Max)	100	50	100	20

1/3L = Shoulder Taper
 BZ = Buffer Zone
 RZ = Roll Ahead Space
 WZ = Work Zone
 R = Runout

PTS 920-2A Stationary Shoulder Closure with Channelizing Devices

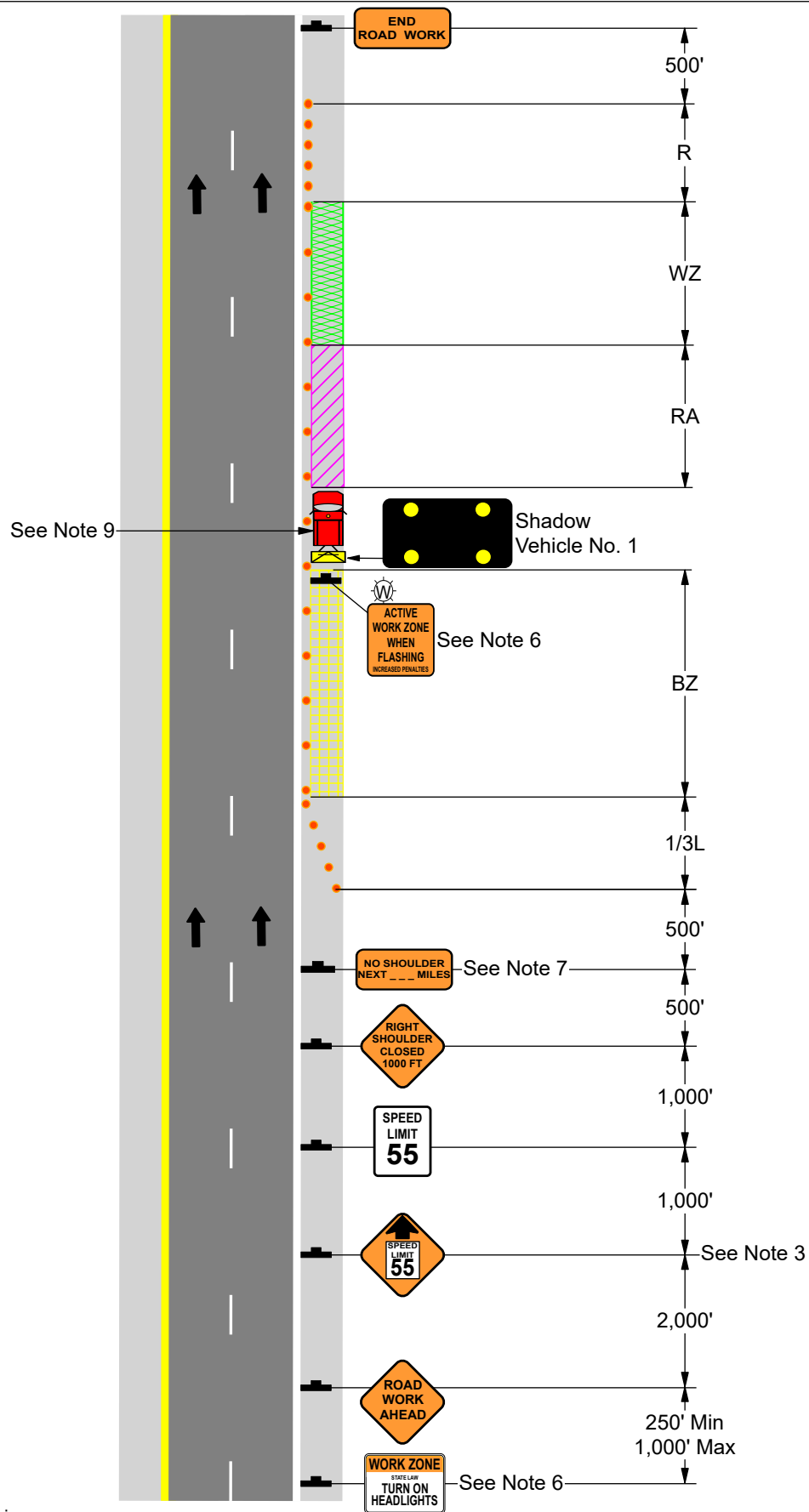

NOTES:
See PTS 920-2 - Notes for applicable notes to this drawing.

See Appendix A for sign descriptions and sizes.

PTS 920-2B Multiple Stationary Shoulder Closures with Channelizing Devices

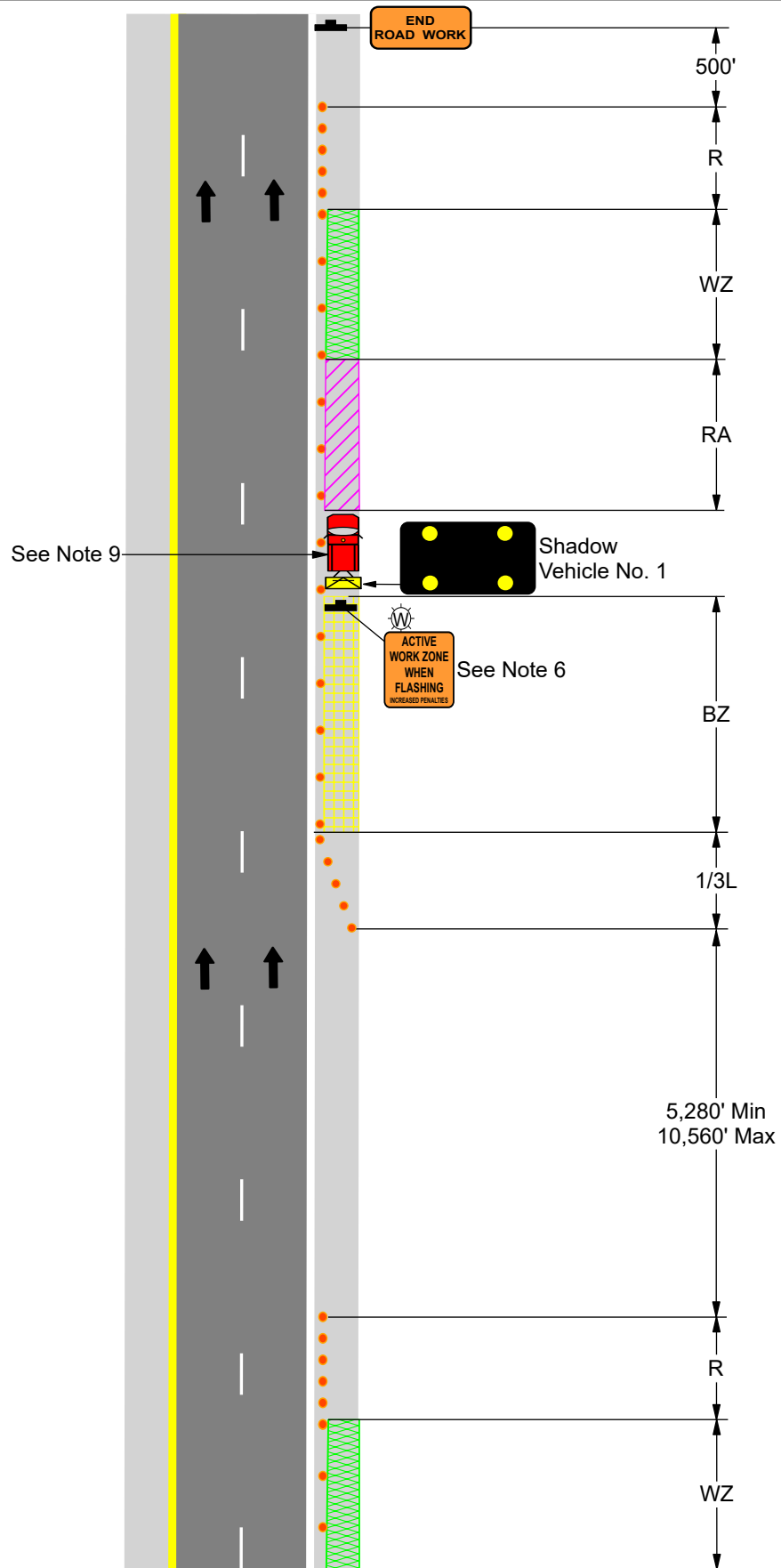

NOTES:
See PTS 920-2 - Notes for applicable notes to this drawing.

See PTS 920-2A for Advance Signing

See Appendix A for sign descriptions and sizes.

PTS 920-3 - Notes

Single Lane Closure with Channelizing Devices

1. For interchange and service plaza ramp signing within the work zone, see PTS 920-7.
2. For left lane work zone use the same sign spacing, location, and pattern but with the signs and PCMS indicating a left lane closure. Do not include arrow on Phase 2 of PCMS 3 with left lane closure.
3. Use channelizing devices with PennDOT approved sequential warning lights in the taper areas for patterns used during hours of darkness.
4. Single lane closure with channelizing devices will not be permitted when all lanes are required to be available in accordance with the allowable working hours or the specified holiday restrictions. Shorten length of single lane pattern to only the length needed for the construction operation. Do not exceed a maximum physical work zone of four (4) miles in length.
5. Single lane shall be established a minimum of 1,000 feet in advance of deceleration ramp or beyond acceleration ramp at interchanges and service plazas, or as directed by the Representative.
6. Install W3-5 sign only in areas where the normal speed limit is 70 MPH.
7. R22-1, W21-19, and Speed Display signs are not required for PTC Maintenance Department Operations.
8. Speed Display Sign shall only be used if the length of the physical work zone is greater than or equal to 500 feet.
9. If active work is being performed at multiple locations throughout the physical work zone, consider the use of additional Shadow Vehicles(s) with Truck Mounted Attenuator prior to each work location. These additional vehicles are incidental to MPT.
10. During high traffic volume periods and as directed by the Representative, change the message on the PCMS to read: PCMS 1 - Phase 1 "USE / BOTH / LANES", Phase 2 "TO / MERGE / POINT"; PCMS 2 - Phase 1 "RIGHT/ LANE / CLOSED", Phase 2 "USE / BOTH/ LANES"; PCMS 3 - Phase 1 "RIGHT / LANE / CLOSED", Phase 2 "MERGE / LEFT / 1500 FT".
11. Compute the minimum desirable merging taper length for reduction in lanes using the following formula:

$$L = S_N \times W$$

Where L = Minimum desirable merging taper length in feet
 W = Width of offset in feet
 S_N = Normal speed limit in miles per hour
12. Additional arrow boards may be used in the closed lane(s) as long as they operate in Caution Mode.
13. For a three (3) lane section of roadway, use the same sign spacing, location, and pattern.

Signs

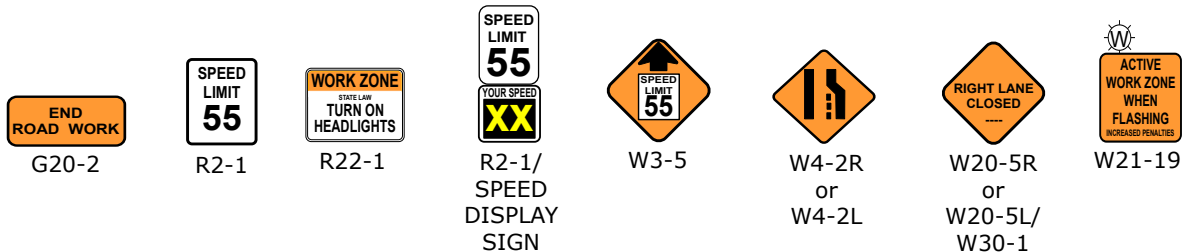

NOTE: See Appendix A for sign descriptions and dimensions.

Distance and Spacing Quick Reference Chart

SPEED	L	1/3 L	BZ	RA	WZ	R	Maximum Channelizing Device Spacing (Feet)		
							L & 1/3L	BZ, RA & WZ	R
MPH	Feet	Feet	Feet	Feet	Mile(s)	Feet			
55	660	220	500 (Min)	250	4 (Max)	100	50	100	20
70	840	280	750 (Min)	250	4 (Max)	100	50	100	20

L = Merging Taper
 1/3L = Shoulder Taper
 BZ = Buffer Zone
 RA = Roll Ahead Space
 WZ = Work Zone
 R = Runout

PTS 920-3 Single Lane Closure with Channelizing Devices

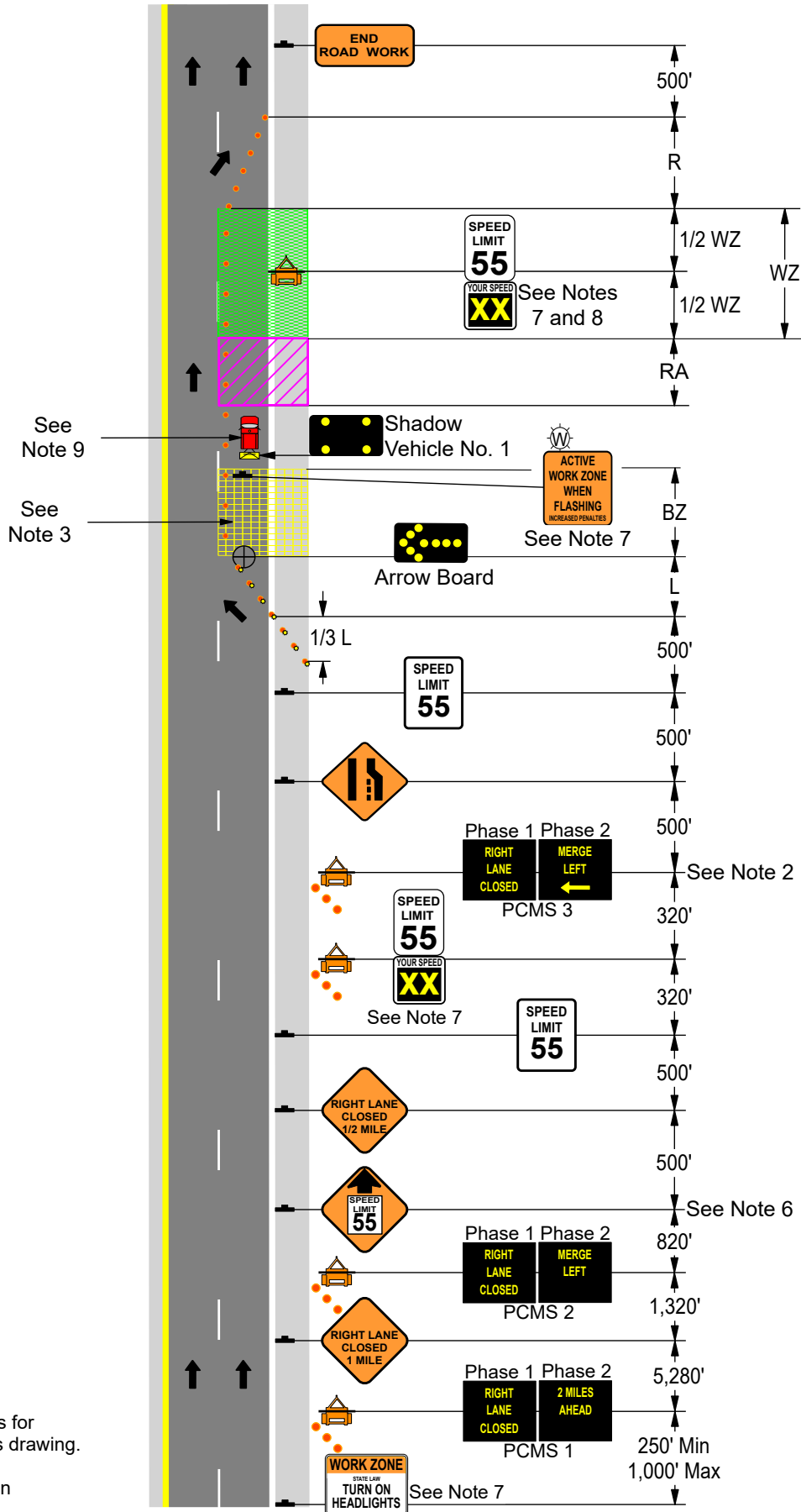

NOTES:
See PTS 920-3 - Notes for applicable notes to this drawing.

See Appendix A for sign descriptions and sizes.

PTS 920-4 - Notes

Dual Lane Closure with Channelizing Devices

1. For interchange and service plaza ramp signing within the work zone, see PTS 920-7.
2. For left and center lane work zone, use the same spacing, location, and pattern but with the signs and PCMS indicating a left and center lane closure. Do not include arrow on Phase 2 of PCMS 3 with left lane closure.
3. Use channelizing devices with PennDOT approved sequential warning lights in the taper areas for patterns used during hours of darkness.
4. Dual lane closure with channelizing devices will not be permitted when all lanes are required to be available in accordance with the allowable working hours or the specified holiday restrictions. Shorten length of single lane pattern to only the length needed for the construction operation. Do not exceed a maximum physical work zone of four (4) miles in length.
5. Single lane shall be established a minimum of 1,000 feet in advance of deceleration ramp or beyond acceleration ramp at interchanges and service plazas, or as directed by the Representative.
6. Install W3-5 sign only in areas where the normal speed limit is 70 MPH.
7. R22-1, W21-19, and Speed Display signs are not required for PTC Maintenance Department Operations.
8. Speed Display Sign shall only be used if the length of the physical work zone is greater than or equal to 500 feet.
9. During high traffic volume periods and as directed by the Representative, change the message on the PCMS to read: PCMS 1 - Phase 1 "USE / ALL / LANES", Phase 2 "TO / MERGE / POINT"; PCMS 2 - Phase 1 "RIGHT / 2 LANES / CLOSED", Phase 2 "USE / ALL / LANES"; PCMS 3 - Phase 1 "RIGHT / 2 LANES / CLOSED", Phase 2 "MERGE / LEFT / 1500 FT".
10. Additional arrow boards may be used in the closed lane(s) as long as they operate in Caution Mode.
11. If active work is being performed at multiple locations throughout the physical work zone, consider the use of additional Shadow Vehicles(s) with Truck Mounted Attenuator prior to each work location. These additional vehicles are incidental to MPT.
12. Compute the minimum desirable merging taper length for reduction in lanes using the following formula:

$$L = S_N \times W$$

Where L = Minimum desirable merging taper length in feet
W = Width of offset in feet
 S_N = Normal speed limit in miles per hour

Signs

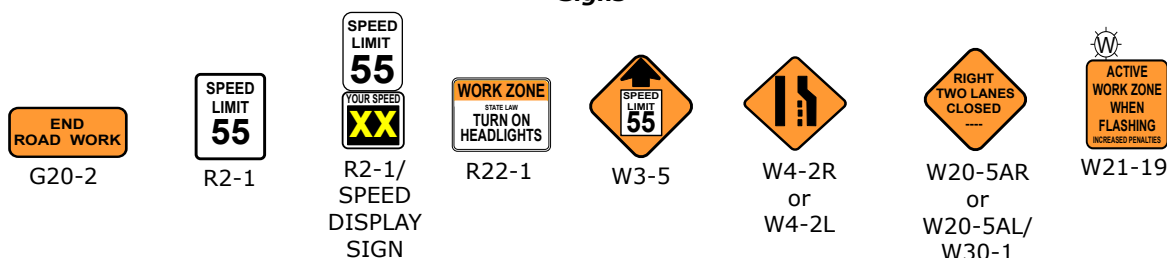

NOTE: See Appendix A for sign descriptions and dimensions.

Distance and Spacing Quick Reference Chart

SPEED	L	1/3 L	BZ 1	BZ 2	RA	WZ	R	Maximum Channelizing Device Spacing (Feet)		
								L & 1/3L	BZ 1, BZ 2, RA & WZ	R
MPH	Feet	Feet	Feet	Feet	Feet	Mile(s)	Feet			
55	660	220	1,320 (Min)	500 (Min)	250	4 (Max)	100	50	100	20
70	840	280	1,680 (Min)	750 (Min)	250	4 (Max)	100	50	100	20

L = Merging Taper
1/3 L = Shoulder Taper
BZ 1 = Buffer Zone 1
BZ 2 = Buffer Zone 2
RA = Roll Ahead Space
WZ = Work Zone
R = Runout

PTS 920-4 Dual Lane Closure with Channelizing Devices

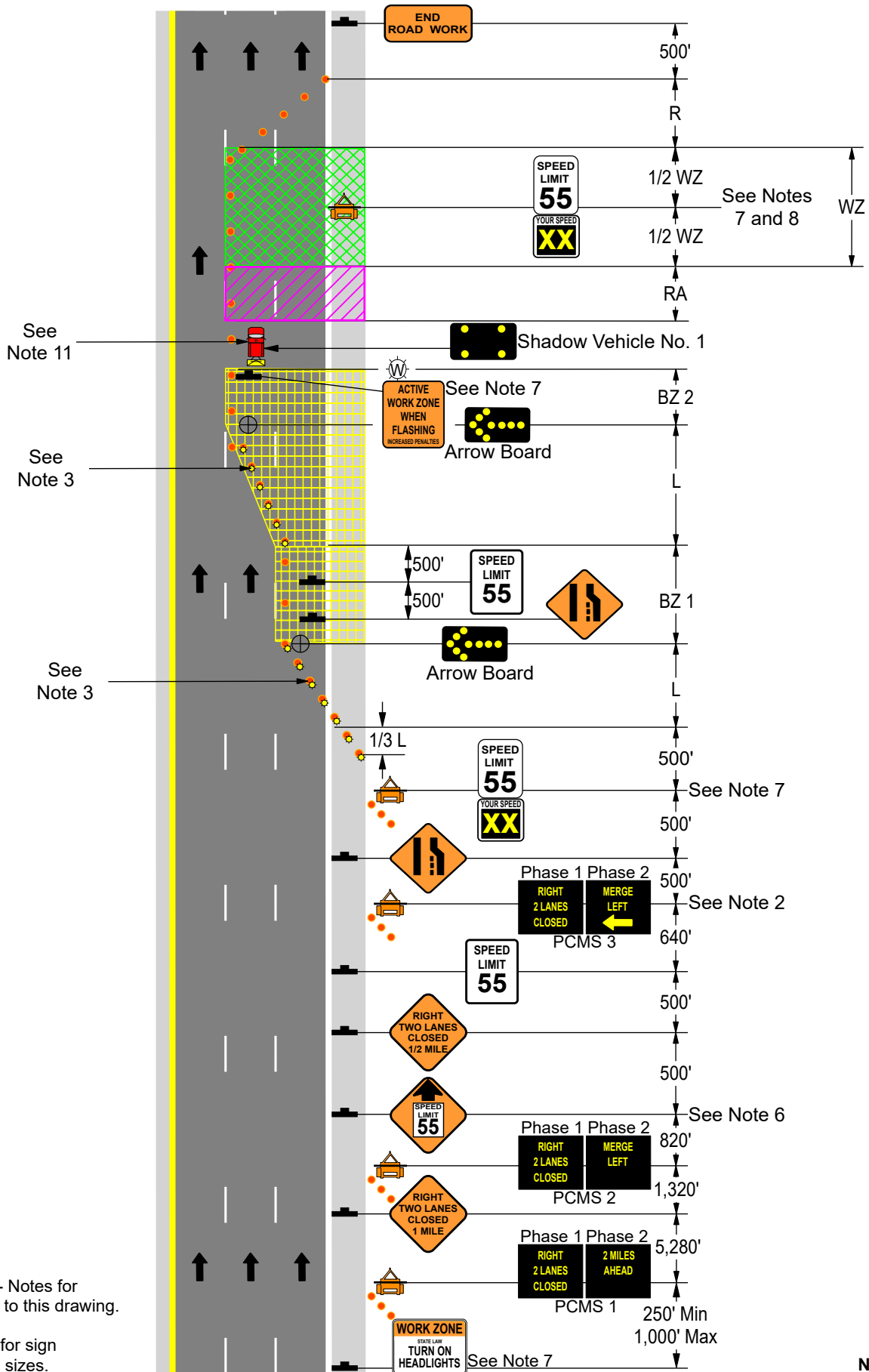

NOTES:
See PTS 920-4 - Notes for applicable notes to this drawing.
See Appendix A for sign descriptions and sizes.

PTS 920-5 - Notes

Right Lane Closure within Transition from 2 to 3 Lanes

1. For interchange and service plaza ramp signing within the work zone, see PTS 920-7.
2. Right lane closure within transition from 2 to 3 lanes will not be permitted when all lanes are required to be available in accordance with the allowable working hours or the specified holiday restrictions. Shorten length of single lane pattern to only the length needed for the construction operation. Do not exceed a maximum physical work zone of four (4) miles in length.
3. Install W3-5 sign only in areas where the normal speed limit is 70 mph.
4. Speed Display Sign shall only be used if the length of the physical work zone is greater than or equal to 500 feet.
5. R22-1, W21-19, and Speed Display signs are not required for PTC Maintenance Department Operations.
6. Compute the minimum desirable shoulder taper length ($1/3L$) for reduction in lanes using the following formula:

$$L = S_N \times W$$
 Where L = Minimum desirable merging taper length in feet
 W = Width of offset in feet
 S_N = Normal speed limit in miles per hour
7. Additional arrow boards may be used in the closed lane(s) as long as they operate in Caution Mode.
8. If active work is being performed at multiple locations throughout the physical work zone, consider the use of additional Shadow Vehicles(s) with Truck Mounted Attenuator prior to each work location. These additional vehicles are incidental to MPT.

Signs

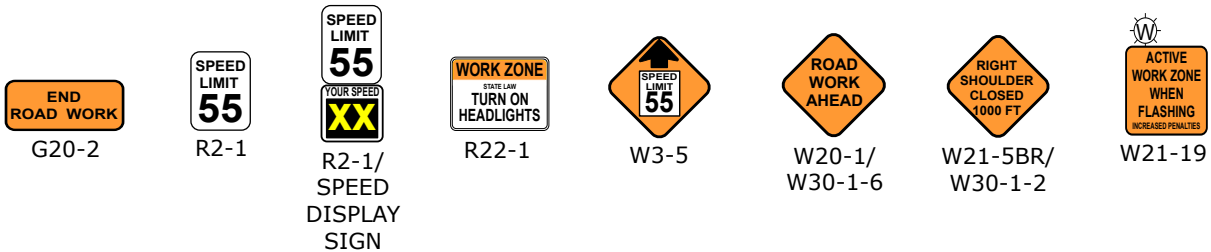

NOTE: See Appendix A for sign descriptions and dimensions.

Distance and Spacing Quick Reference Chart

SPEED	1/3 L	BZ	RA	WZ	R	Maximum Channelizing Device Spacing (Feet)		
						1/3 L	BZ, RA & WZ	R
MPH	Feet	Feet	Feet	Mile(s)	Feet	1/3 L	BZ, RA & WZ	R
55	220	500 (Min)	250	4 (Max)	100	50	100	20
70	280	750 (Min)	250	4 (Max)	100	50	100	20

$1/3L$ = Shoulder Taper
 BZ = Buffer Zone
 RA = Roll Ahead Space
 WZ = Work Zone
 R = Runout

PTS 920-5 Right Lane Closure within Transition from 2 to 3 Lanes

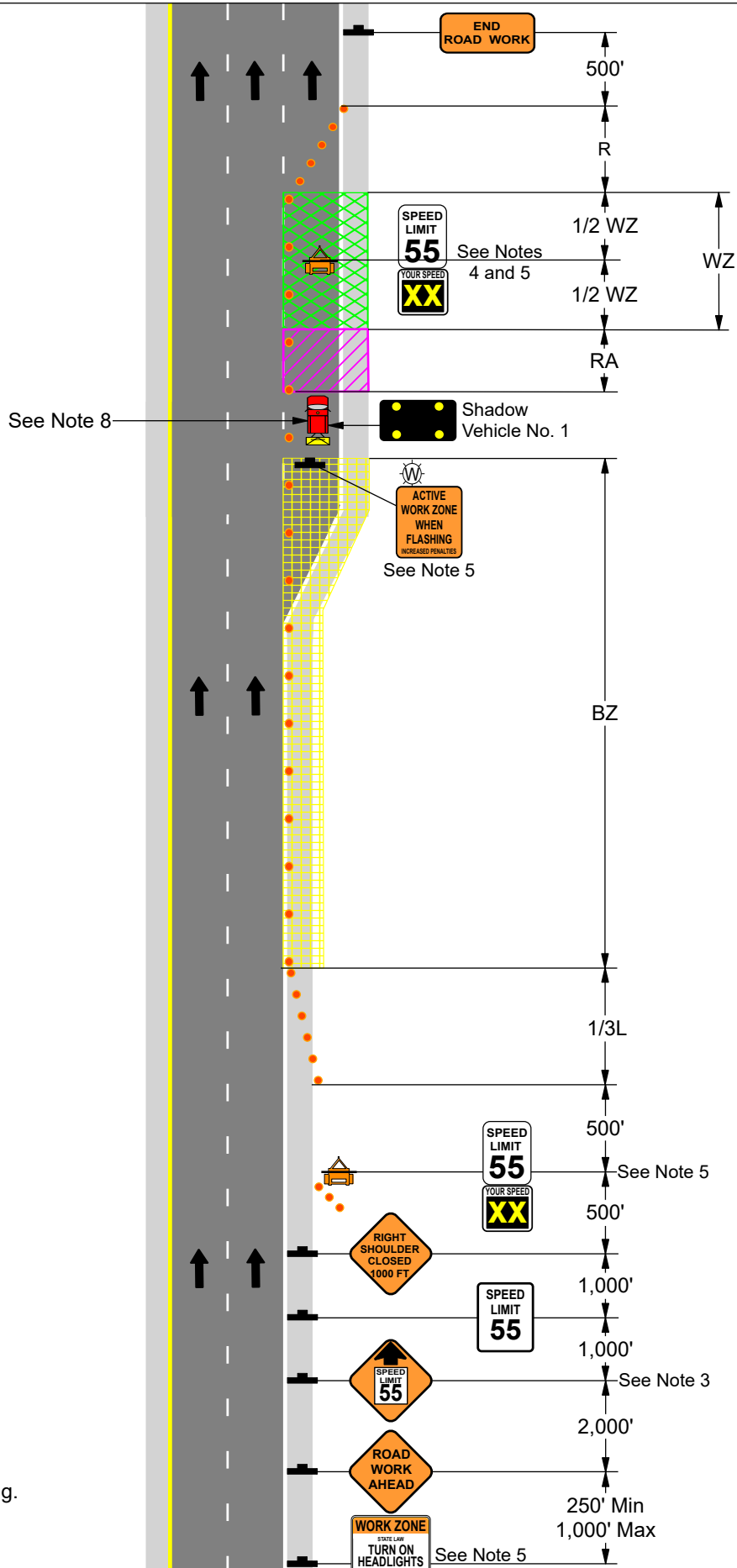

NOTES:
See PTS 920-5 - Notes for applicable notes to this drawing.

See Appendix A for sign descriptions and sizes.

PTS 920-6 - Notes

Center / Right Lane Closure within Transition from 2 to 3 Lanes

1. For interchange and service plaza ramp signing within the work zone, see PTS 920-7.
2. Use channelizing devices with PennDOT approved sequential warning lights in the taper area for patterns used during hours of darkness.
3. Center/right lane closure within transition from 2 to 3 lanes will not be permitted when all lanes are required to be available in accordance with the allowable working hours or the specified holiday restrictions. Shorten length of single lane pattern to only the length needed for the construction operation. Do not exceed a maximum physical work zone of four (4) miles in length.
4. Single lane shall be established a minimum of 1,000 feet in advance of deceleration ramp or beyond acceleration ramp at interchanges or service plazas, or as directed by the Representative.
5. Install W3-5 sign only in areas where the normal speed limit is 70 mph.
6. Speed Display Sign shall only be used if the length of the physical work zone is greater than or equal to 500 feet.
7. R22-1, W21-19, and Speed Display signs are not required for PTC Maintenance Department Operations.
8. During high traffic volume periods and as directed by the Representative, change the message on the PCMS to read: PCMS 1 - Phase 1 "USE / BOTH / LANES", Phase 2 "TO / MERGE / POINT"; PCMS 2 - Phase 1 "RIGHT / LANE / CLOSED", Phase 2 "USE / BOTH / LANES"; PCMS 3 - Phase 1 "RIGHT / LANE / CLOSED", Phase 2 "MERGE / LEFT / 1500 FT".
9. Compute the minimum merging taper length for reduction in lanes using the following formula:

$$L = S_N \times W$$

Where L = Minimum desirable merging taper length in feet
 W = Width of offset in feet
 S_N = Normal speed limit in miles per hour
10. Additional arrow boards may be used in the closed lane(s) as long as they operate in Caution Mode.
11. If active work is being performed at multiple locations throughout the physical work zone, consider the use of additional Shadow Vehicles(s) with Truck Mounted Attenuator prior to each work location. These additional vehicles are incidental to MPT.

Signs

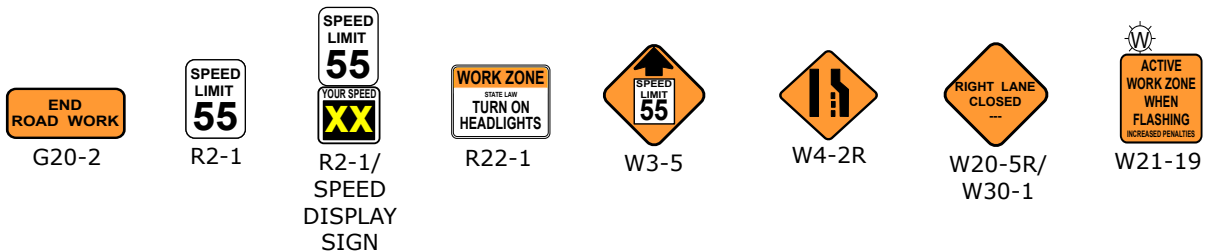

NOTE: See Appendix A for sign descriptions and dimensions.

Distance and Spacing Quick Reference Chart

SPEED MPH	L Feet	1/3 L Feet	BZ Feet	RA Feet	WZ Mile(s)	R Feet	Maximum Channelizing Device Spacing (Feet)		
							L & 1/3L	BZ, RA & WZ	R
55	660	220	500 (Min)	250	4 (Max)	100	50	100	20
70	840	280	750 (Min)	250	4 (Max)	100	50	100	20

L = Merging Taper
 1/3L = Shoulder Taper
 BZ = Buffer Zone
 RA = Roll Ahead Space
 WZ = Work Zone
 R = Runout

PTS 920-6 Center / Right Lane Closure within Transition from 2 to 3 Lanes

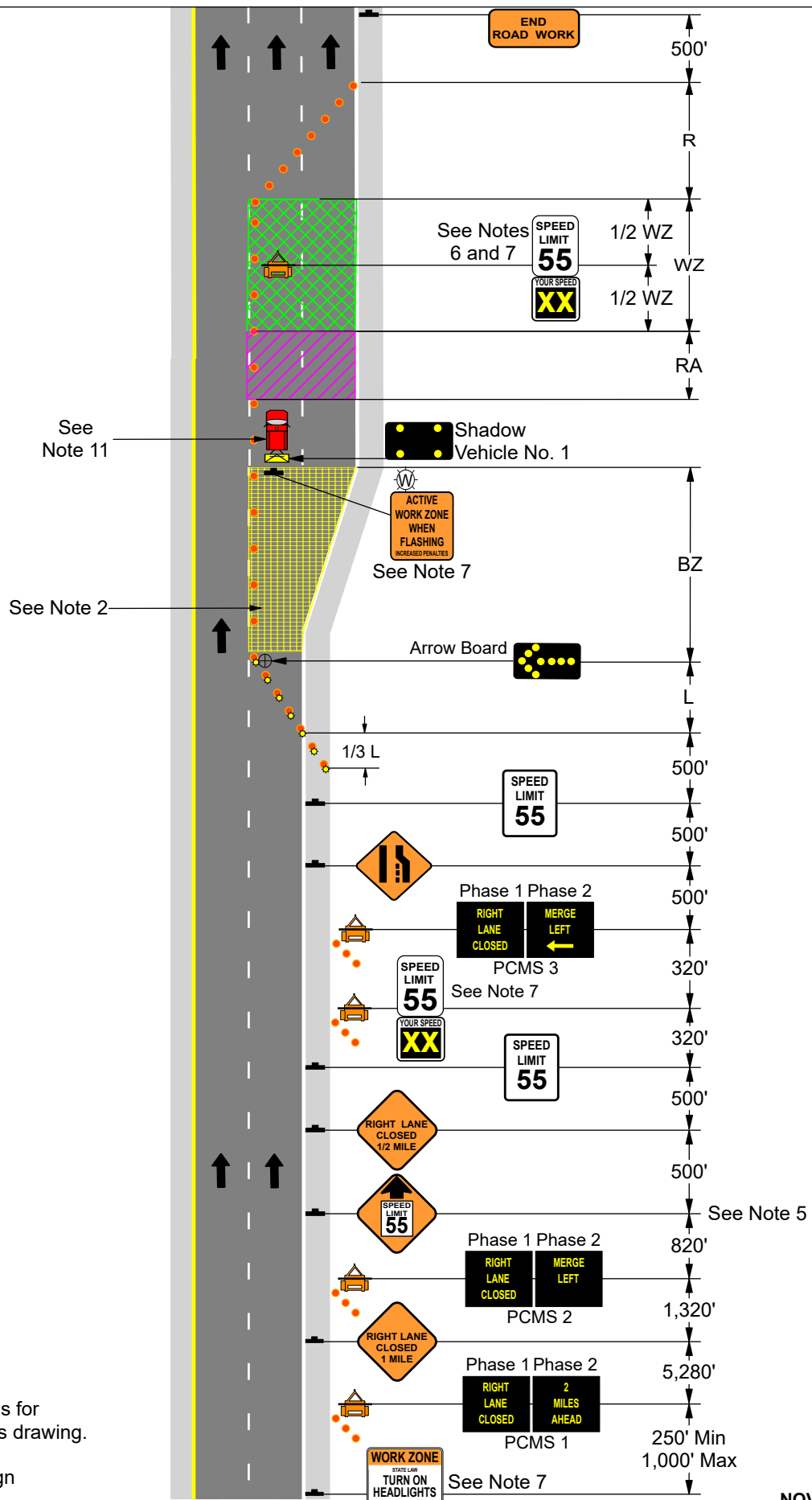

NOTES:
See PTS 920-6 - Notes for applicable notes to this drawing.

See Appendix A for sign descriptions and sizes.

PTS 920-7 - Notes

Lane Closure Traffic Pattern for Interchange and Service Plaza Areas

1. Single lane shall be established per PTS 920-3 or PTS 920-4 a minimum of 1,000 feet in advance of deceleration ramp or beyond acceleration ramp at interchanges and service plazas, or as directed by the Representative.
2. MPT-06 sign:
 - A. Use for interchange ramp only.
 - B. Cover or remove from the site when not in use.
3. MPT-08 sign:
 - A. Use for service plaza ramp only.
 - B. Cover or remove from the site when not in use.
4. Lane closure traffic pattern for interchanges and service plazas will not be permitted when all lanes are required to be available in accordance with the allowable working hours or the specified holiday restrictions.
5. Channelizing devices spaced at 100 feet except where noted.
6. Space signs evenly at 200 feet minimum spacing, or as conditions warrant.
7. R22-1 and W21-19 signs are not required for PTC Maintenance Department Operations.
8. Display Exit Number or Service Plaza on Phase 1 of PCMS if space allows.
9. PTS 920-7A, Lane Closure Traffic Pattern for Interchange and Service Plaza Areas with Yield Control, to be used unless work zone is in the right lane and within 1,080' of beginning of acceleration lane. If 780' of acceleration lane and 300' of taper cannot be provided use PTS 920-7B, Lane Closure Traffic Pattern for Interchange and Service Plaza Areas with Stop Control.
10. PCMS is incidental to MPT.

Signs

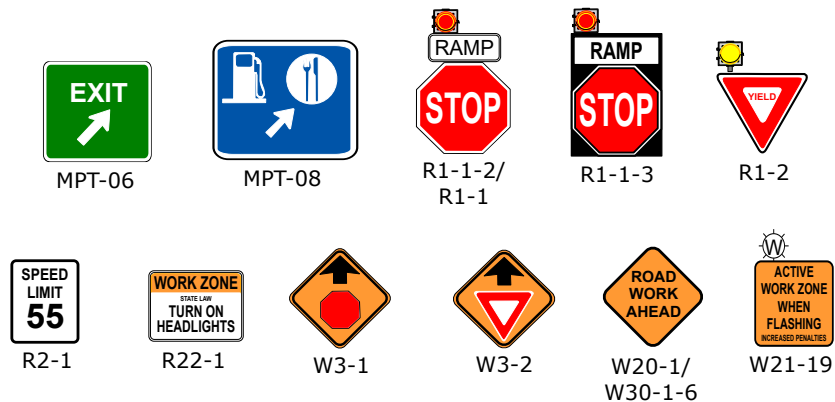

NOTE: See Appendix A for sign descriptions and dimensions.

PTS 920-7A Lane Closure Traffic Pattern for Interchange and Service Plaza Areas with Yield Control

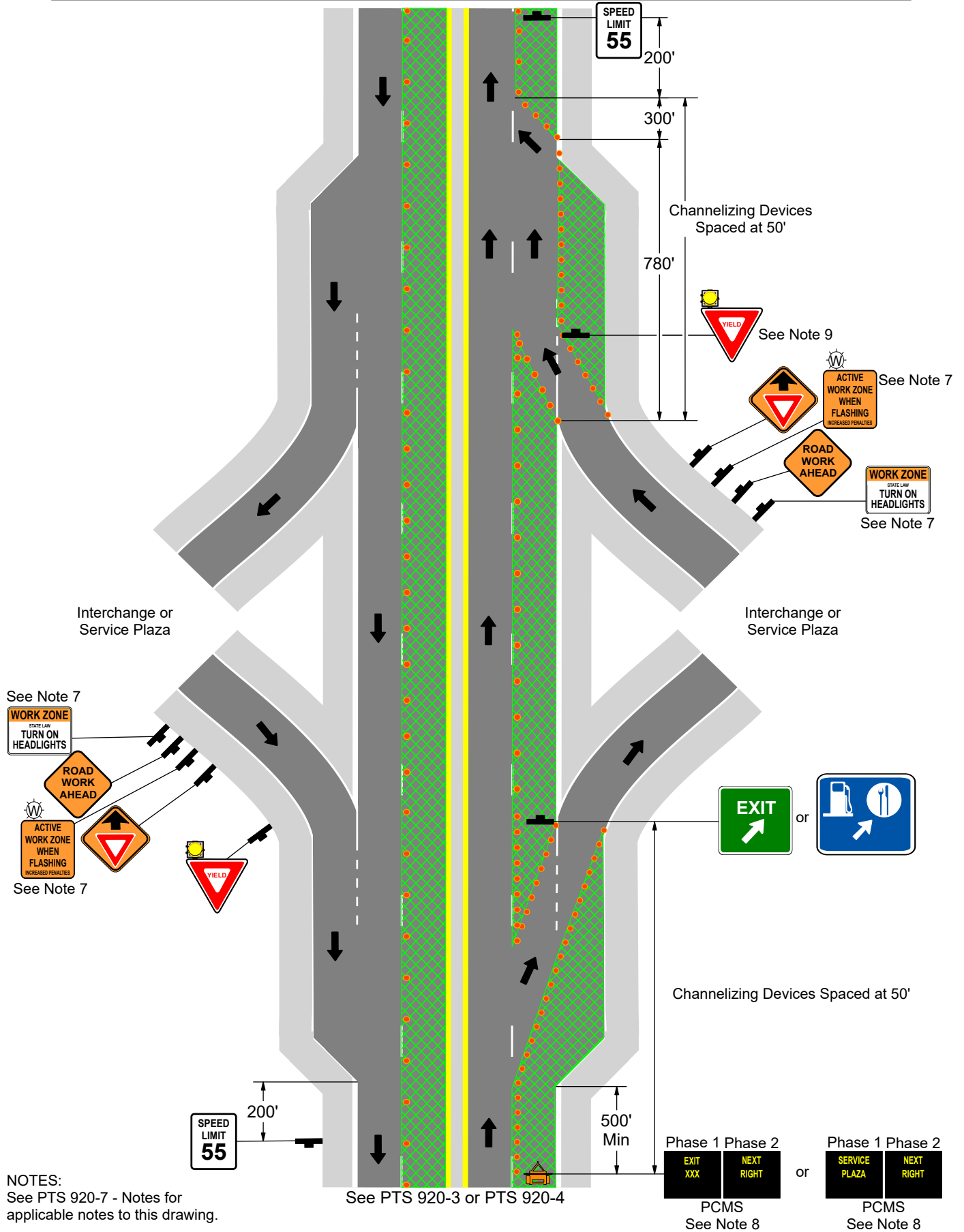

NOTES:
See PTS 920-7 - Notes for applicable notes to this drawing.

See Appendix A for sign descriptions and sizes.

PTS 920-7B Lane Closure Traffic Pattern for Interchange and Service Plaza Areas with Stop Control

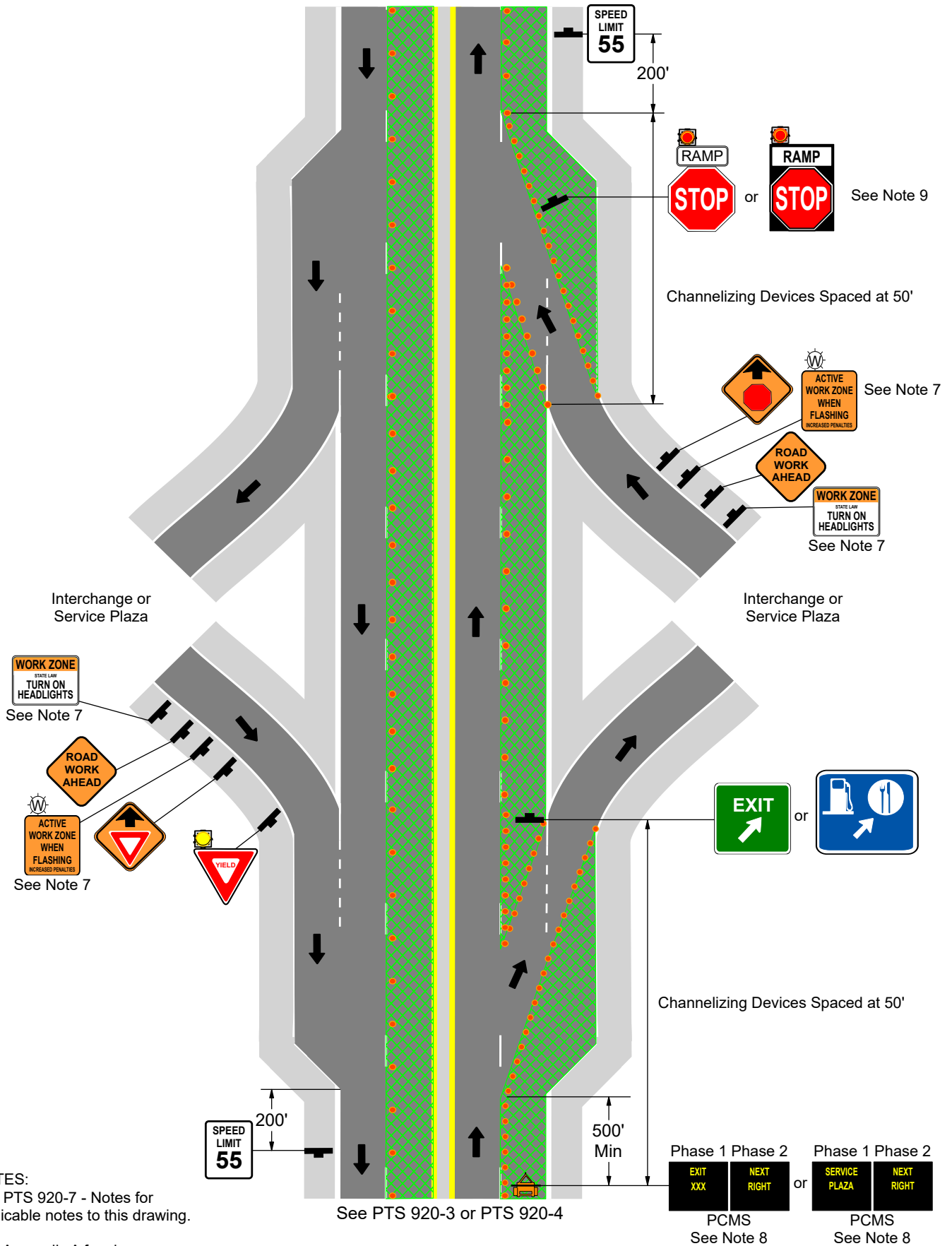

NOTES:
See PTS 920-7 - Notes for applicable notes to this drawing.

See Appendix A for sign descriptions and sizes.

PTS 920-8 - Notes

Multiple Single Lane Closure Traffic Patterns

1. For interchange and service plaza ramp signing within the work zone, see PTS 920-7.
2. For left lane work zone, use the same sign spacing, location and pattern but with the signs and PCMS indicating the left lane is closed. Do not include arrow on Phase 2 of PCMS 5 with left lane closure.
3. For advanced signing, see PTS 920-3.
4. Use channelizing devices with PennDOT approved sequential warning lights in the taper area for patterns used during hours of darkness.
5. Multiple traffic patterns will not be permitted when all lanes are required to be available in accordance with the available working hours or the specified holiday restrictions. Shorten length of single lane pattern to only the length needed for construction operation. Do not exceed a maximum physical work zone four (4) miles in length for each single lane traffic pattern.
6. Single lane shall be established a minimum of 1,000 feet in advance of deceleration ramp or beyond acceleration ramp at interchanges and service plazas, or as directed by the Representative.
7. Install W3-5 sign only in the areas where the normal speed limit is 70 MPH.
8. Speed Display Sign shall only be used if the length of the physical work zone is greater than or equal to 500 feet.
9. Compute the minimum desirable merging taper length for reduction in lanes using the following formula:

$$L = S_N \times W$$

Where L = Minimum desirable merging taper length in feet
 W = Width of offset in feet
 S_N = Normal speed limit in miles per hour
10. W21-19 and Speed Display signs are not required for PTC Maintenance Department Operations.
11. If active work is being performed at multiple locations throughout the physical work zone, consider the use of additional Shadow Vehicles(s) with Truck Mounted Attenuator prior to each work location. These additional vehicles are incidental to MPT.

Signs

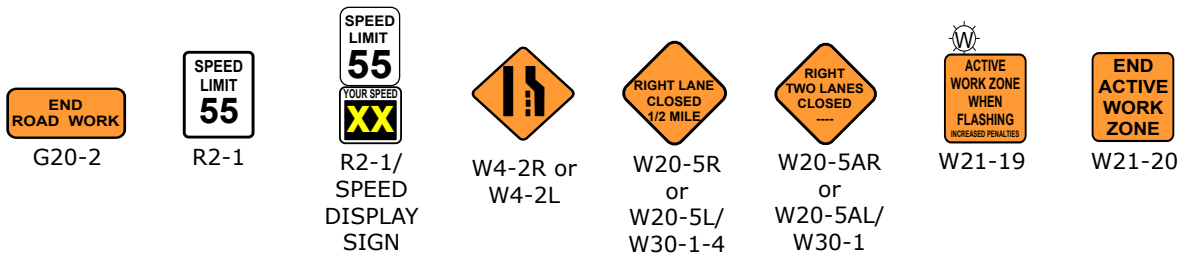

NOTE: See Appendix A for sign descriptions and dimensions.

Distance and Spacing Quick Reference Chart

SPEED	L	1/3 L	BZ	RA	WZ	R	Maximum Channelizing Device Spacing (Feet)		
							L & 1/3L	BZ, RA & WZ	R
MPH	Feet	Feet	Feet	Feet	Mile(s)	Feet			
55	660	220	500 (Min)	250	4 (Max)	100	50	100	20
70	840	280	750 (Min)	250	4 (Max)	100	50	100	20

L = Merging Taper
 1/3L = Shoulder Taper
 BZ = Buffer Zone
 RA = Roll Ahead Space
 WZ = Work Zone
 R = Runout

PTS 920-8 Multiple Single Lane Closure Traffic Patterns

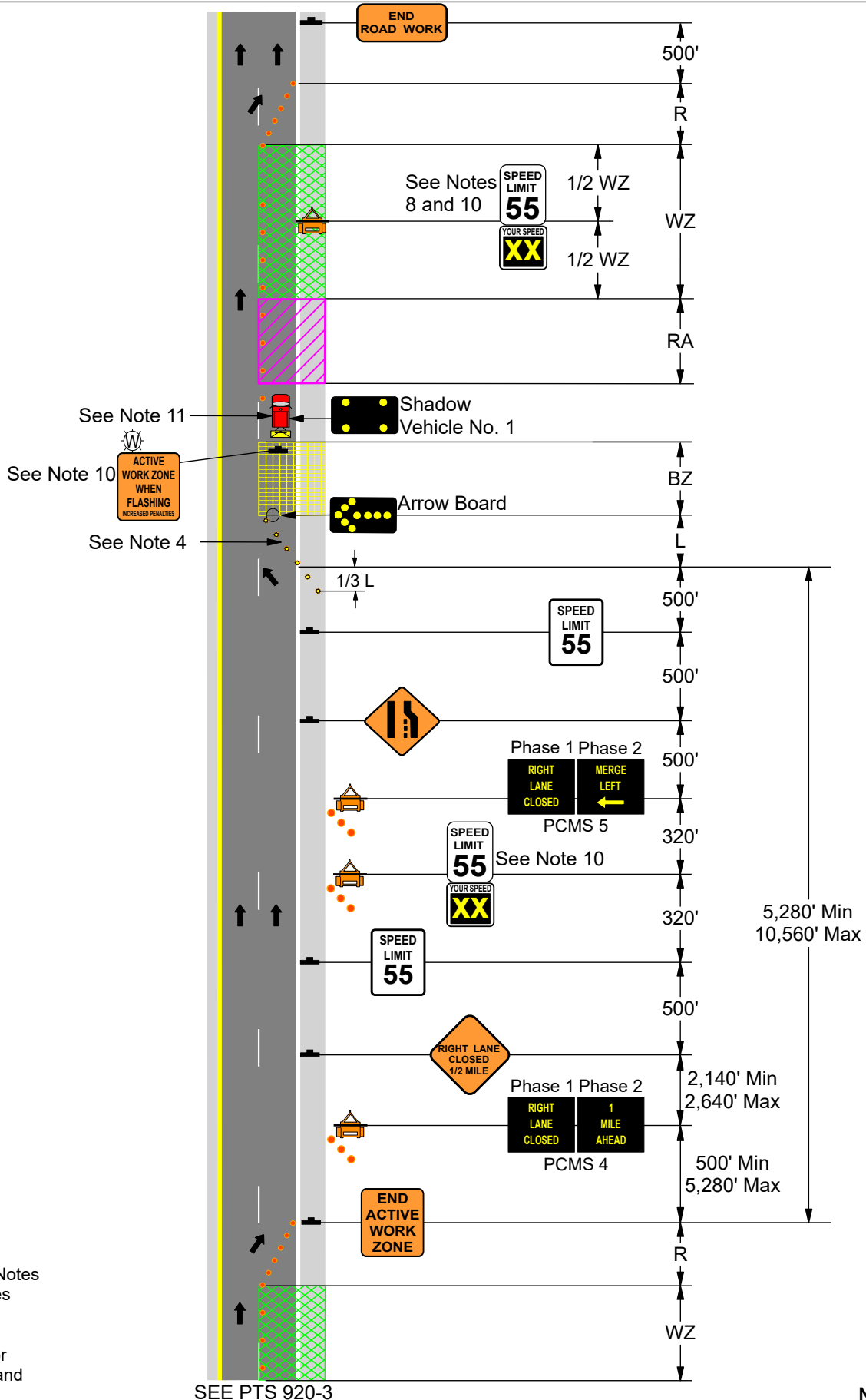

NOTES:
See PTS 920-8 - Notes
for applicable notes
to this drawing.

See Appendix A for
sign descriptions and
sizes.

SEE PTS 920-3

PTS 920-9 - Notes

Multiple Dual Lane Closure Traffic Patterns

1. For interchange and service plaza ramp signing within the work zone, see PTS 920-7.
2. For left lane work zone, use the same sign spacing, location and pattern but with the signs and PCMS indicating the left lane is closed. Do not include arrow on Phase 2 of PCMS 5 with left lane closure.
3. For advanced signing, see PTS 920-4.
4. Use channelizing devices with PennDOT approved sequential warning lights in the taper area for patterns used during hours of darkness.
5. Multiple traffic patterns will not be permitted when all lanes are required to be available in accordance with the available working hours or the specified holiday restrictions. Shorten length of single lane pattern to only the length needed for construction operation. Do not exceed a maximum physical work zone four (4) miles in length for each dual lane traffic pattern.
6. Single lane shall be established a minimum of 1,000 feet in advance of deceleration ramp or beyond acceleration ramp at interchanges and service plazas, or as directed by the Representative.
7. Install W3-5 sign only in the areas where the normal speed limit is 70 MPH.
8. Speed Display Sign shall only be used if the length of the physical work zone is greater than or equal to 500 feet.
9. Compute the minimum desirable merging taper length for reduction in lanes using the following formula:

$$L = S_N \times W$$
 Where L = Minimum desirable merging taper length in feet
 W = Width of offset in feet
 S_N = Normal speed limit in miles per hour
10. W21-19 and Speed Display signs are not required for PTC Maintenance Department Operations.
11. If active work is being performed at multiple locations throughout the physical work zone, consider the use of additional Shadow Vehicles(s) with Truck Mounted Attenuator prior to each work location. These additional vehicles are incidental to MPT.

Signs

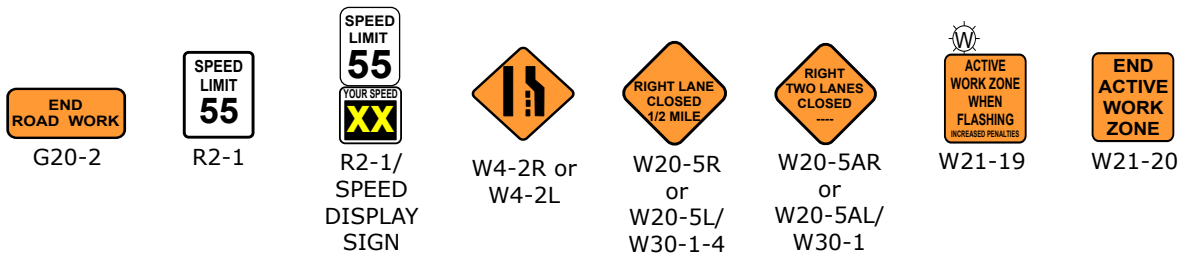

NOTE: See Appendix A for sign descriptions and dimensions.

Distance and Spacing Quick Reference Chart

SPEED	L	1/3 L	BZ 1	BZ 2	RA	WZ	R	Maximum Channelizing Device Spacing (Feet)		
								L & 1/3L	BZ 1, BZ 2, RA & WZ	R
MPH	Feet	Feet	Feet	Feet	Feet	Mile(s)	Feet			
55	660	220	1,320 (Min)	500 (Min)	250	4 (Max)	100	50	100	20
70	840	280	1,680 (Min)	750 (Min)	250	4 (Max)	100	50	100	20

L = Merging Taper
 1/3L = Shoulder Taper
 BZ 1 = Buffer Zone 1
 BZ 2 = Buffer Zone 2
 RA = Roll Ahead Space
 WZ = Work Zone
 R = Runout

PTS 920-9 Multiple Dual Lane Closure Traffic Patterns

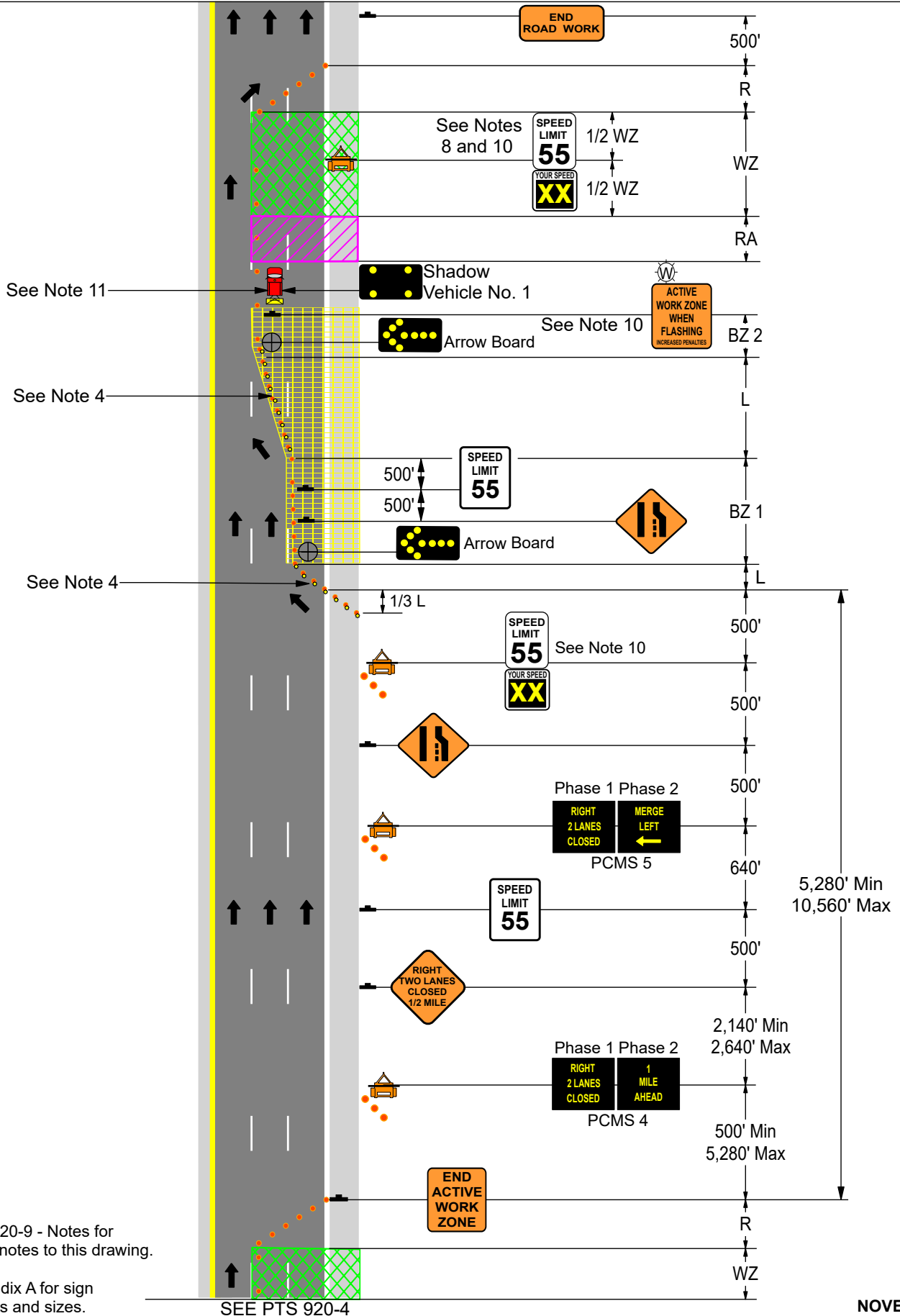

NOTES:
See PTS 920-9 - Notes for applicable notes to this drawing.

See Appendix A for sign descriptions and sizes.

PTS 920-10 - Notes Allegheny Tunnel Crossover Pattern

1. Use existing "DO NOT CROSS CENTER LINE" sign and existing traffic control signal at portal.
2. Use channelizing devices with PennDOT approved sequential warning lights in the taper areas for patterns used during hours of darkness.
3. Tunnel crossover pattern will not be permitted when all lanes are required to be available in accordance with the allowable working hours or the specified holiday restrictions.
4. Utilize existing CMS and place one (1) PCMS in each direction 1/2 mile to 1 mile in advance of the lane closure when utilizing the Tunnel Crossover Pattern with the following Message:

Phase 1:	Phase 2:
TRUCKS	NARROW
USE	LANE IN
CAUTION	TUNNEL

PCMS not required for PTC Maintenance Operations.

5. During high traffic volume periods and as directed by the Representative, change the message on the PCMS to read: PCMS 1 - Phase 1 "USE / ALL / LANES", Phase 2 "TO / MERGE / POINT"; PCMS 2 - Phase 1 "LEFT / 2 LANES / CLOSED", Phase 2 "USE / ALL / LANES"; PCMS 3 - Phase 1 "LEFT / 2 LANES / CLOSED", Phase 2 "MERGE / RIGHT / 1500 FT"; PCMS 7 - Phase 1 "LEFT / LANE / CLOSED", Phase 2 "USE / BOTH / LANES"; PCMS 8 - Phase 1 "USE / BOTH / LANES", Phase 2 "TO / MERGE / POINT";

6. Compute the minimum desirable merging taper length for reduction in lanes using the following formula:

$$L = S_N \times W$$

Where L = Minimum desirable merging taper length in feet
W = Width of offset in feet
 S_N = Normal speed limit in miles per hour

7. R22-1 and Speed Display Sign not required for PTC Maintenance Department Operations.

Signs

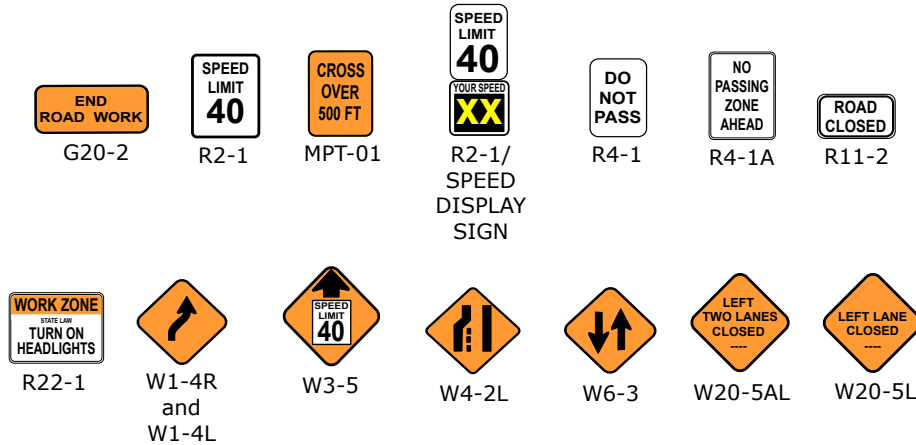

NOTE: See Appendix A for sign descriptions and dimensions.

Distance and Spacing Quick Reference Chart

SPEED	L	1/3 L	BZ 1	BZ 2	R	Maximum Channelizing Device Spacing (Feet)					
						L	1/3 L	BZ 1	BZ 2	WZ	R
MPH	Feet	Feet	Feet	Feet	Feet	L	1/3 L	BZ 1	BZ 2	WZ	R
55	660	220	1,320 (Min)	500 (Min)	100	50	50	100	100	100	20

L = Merging Taper
1/3 L = Shoulder Taper
BZ 1 = Buffer Zone 1
BZ 2 = Buffer Zone 2
RA = Roll Ahead Space
WZ = Work Zone
R = Runout

PTS 920-10 Allegheny Tunnel Crossover Pattern (Drawing 1 of 3)

SEE PTS 920-10
(Drawing 2 of 3)

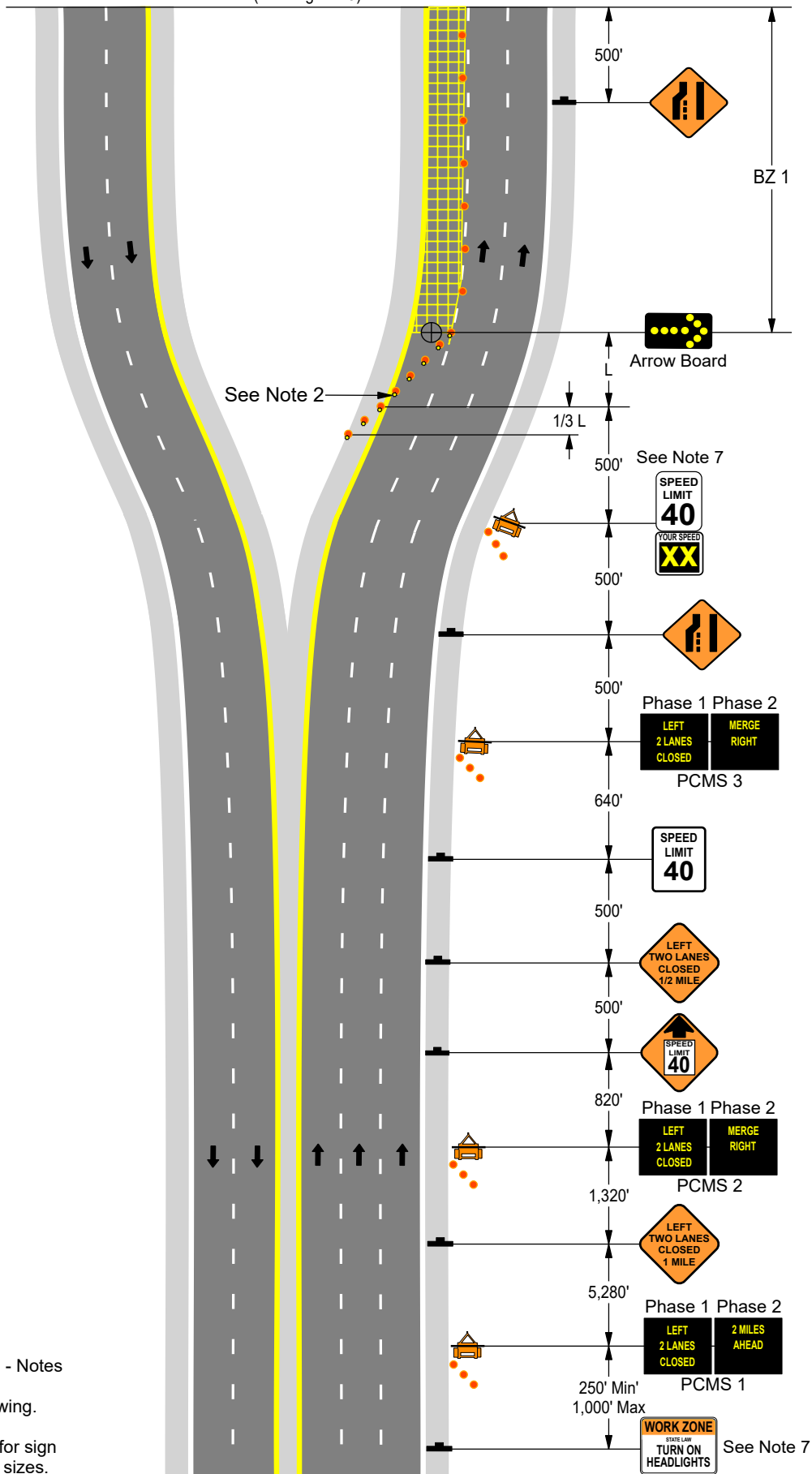

NOTES:
See PTS 920-10 - Notes
for applicable
notes to this drawing.

See Appendix A for sign
descriptions and sizes.

See Note 7

PTS 920-10 Allegheny Tunnel Crossover Pattern (Drawing 2 of 3)

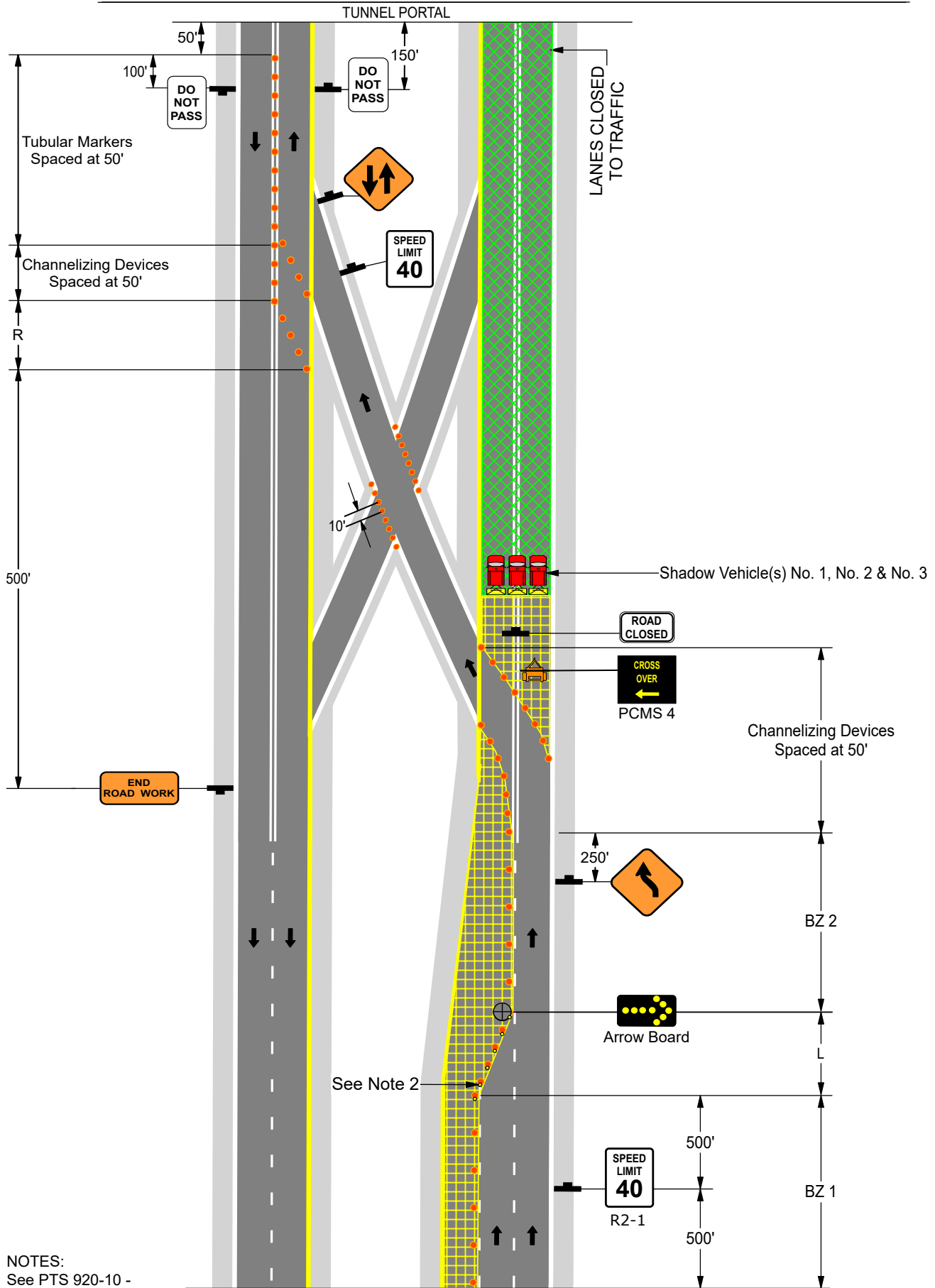

NOTES:
See PTS 920-10 -
Notes for applicable
notes to this drawing

SEE PTS 920-10
(Drawing 1 of 3)

PTS 920-10 Allegheny Tunnel Crossover Pattern (Drawing 3 of 3)

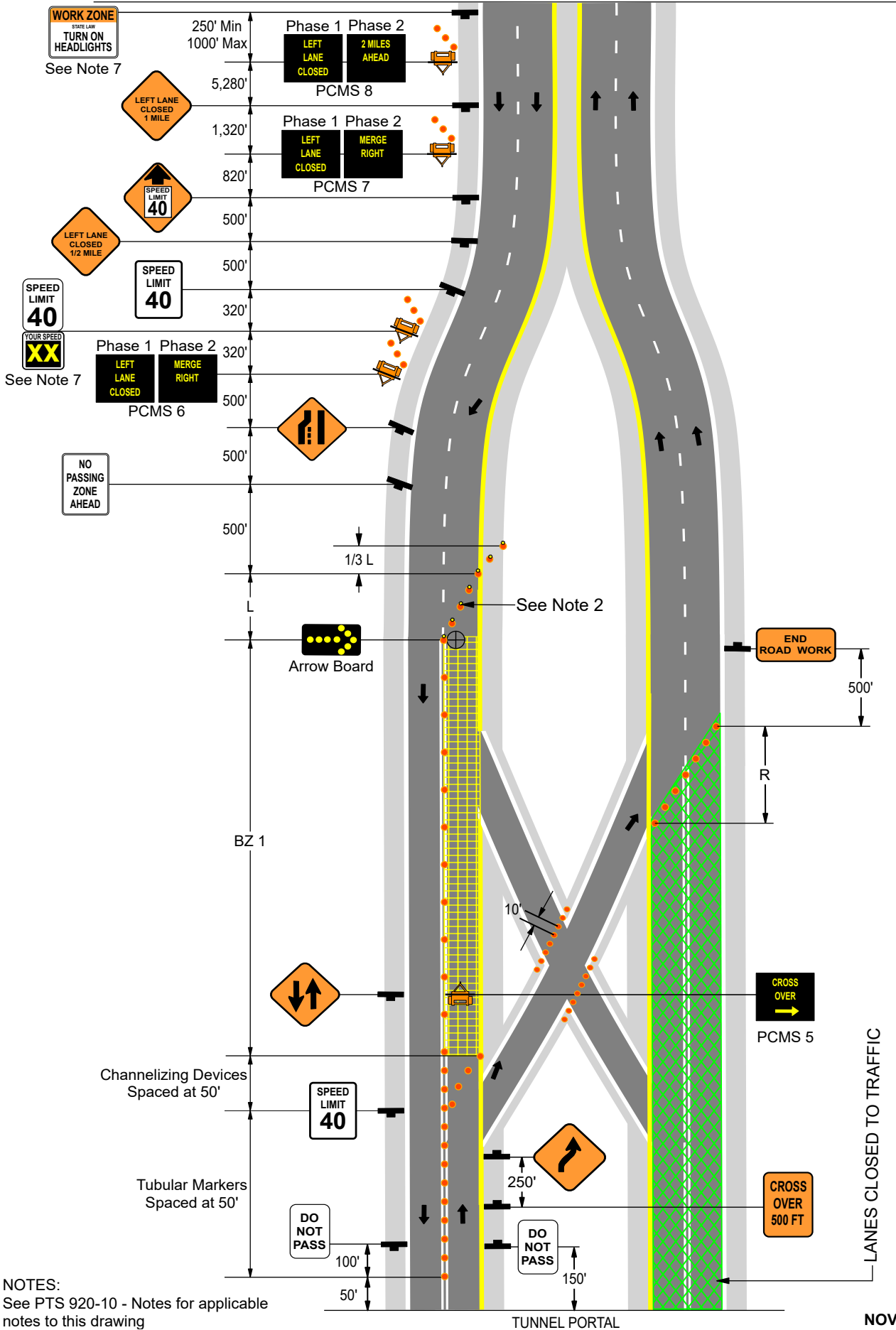

NOTES:
See PTS 920-10 - Notes for applicable notes to this drawing

PTS 920-11 - Notes

Tuscarora Tunnel Crossover Pattern

1. Use existing "DO NOT CROSS CENTER LINE" sign and existing traffic control signal at portal.
2. Use channelizing devices with PennDOT approved sequential warning lights in the taper areas for patterns used during hours of darkness.
3. Utilize existing CMS and place one (1) PCMS in each direction 1/2 mile to 1 mile in advance of the lane closure when utilizing the Tunnel Crossover Pattern with the following Message:

Phase 1:	Phase 2:
TRUCKS	NARROW
USE	LANE IN
CAUTION	TUNNEL

PCMS not required for PTC Maintenance Operations.

4. Tunnel crossover pattern will not be permitted when all lanes are required to be available in accordance with the allowable working hours or the specified holiday restrictions.

5. During high traffic volume periods and as directed by the Representative, change the message on the PCMS to read: PCMS 1 and 8 - Phase 1 "USE / BOTH / LANES", Phase 2 "TO / MERGE / POINT"; PCMS 2 - Phase 1 "LEFT / LANE / CLOSED", Phase 2 "USE / BOTH / LANES"; PCMS 3 - Phase 1 "LEFT / LANE / CLOSED", Phase 2 "MERGE / RIGHT / 1500 FT"; PCMS 7 - Phase 1 "LEFT / LANE / CLOSED", Phase 2 "USE / BOTH / LANES"; PCMS 6 - Phase 1 "LEFT / LANE / CLOSED", Phase 2 "MERGE / RIGHT / 1500 FT".

6. R22-1 and Speed Display signs are not required for PTC Maintenance Department Operation.

Signs

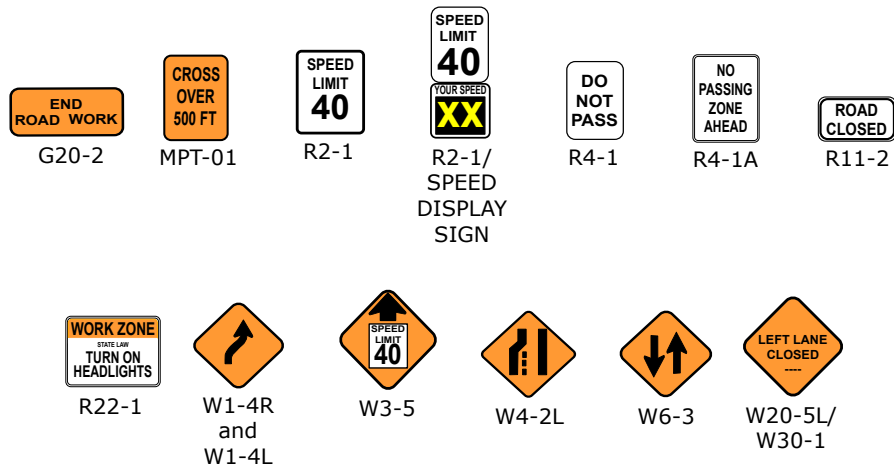

NOTE: See Appendix A for sign descriptions and dimensions.

Distance and Spacing Quick Reference Chart

SPEED	BZ	R	Maximum Channelizing Device Spacing (Feet)	
			BZ	R
MPH	Feet	Feet		
55	1,320 (Min)	100	50	20

R = Runout
BZ = Buffer Zone

PTS 920-11 Tuscarora Tunnel Crossover Pattern (Drawing 1 of 2)

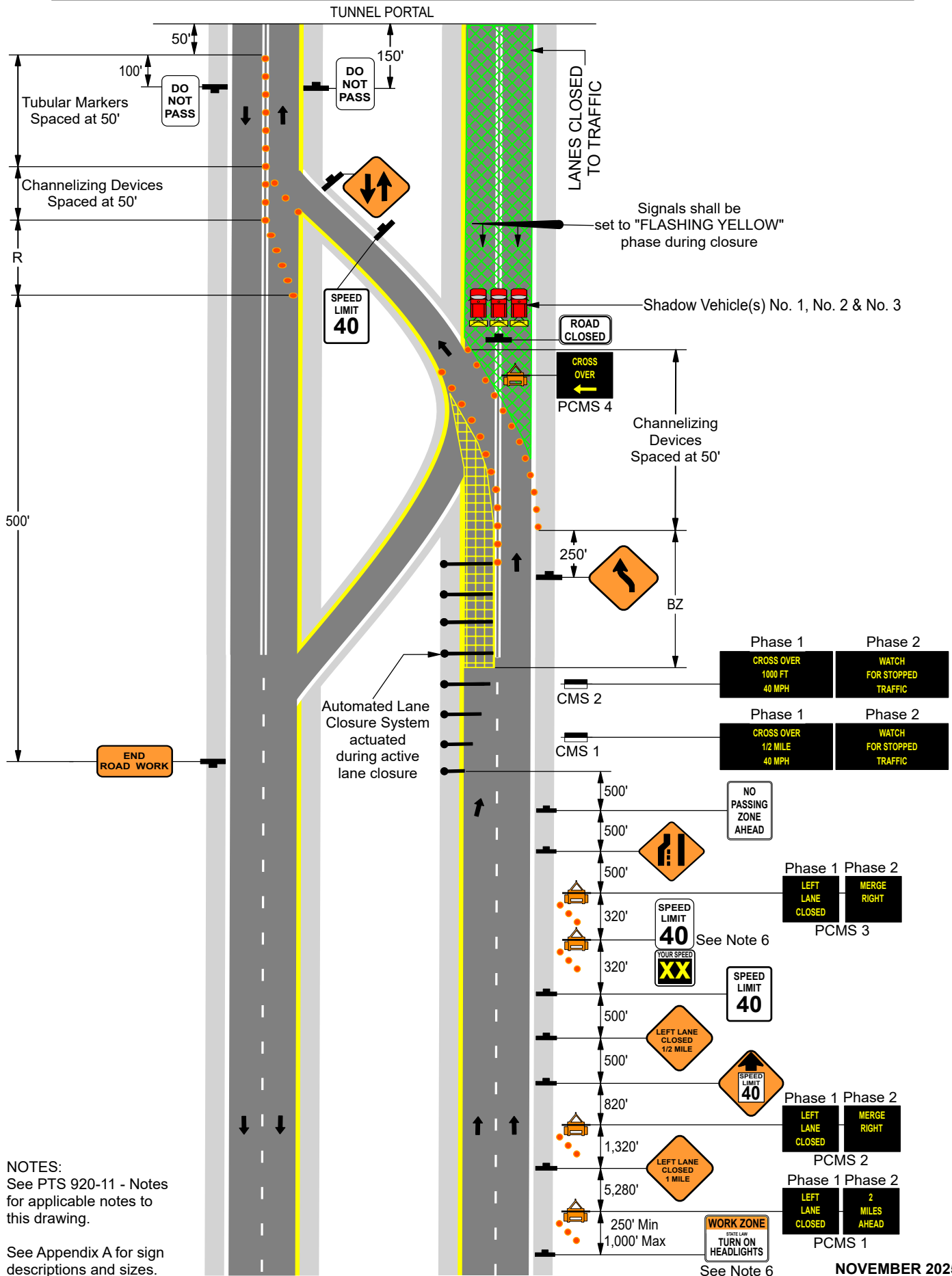

NOTES:
See PTS 920-11 - Notes for applicable notes to this drawing.

See Appendix A for sign descriptions and sizes.

PTS 920-11 Tuscarora Tunnel Crossover Pattern (Drawing 2 of 2)

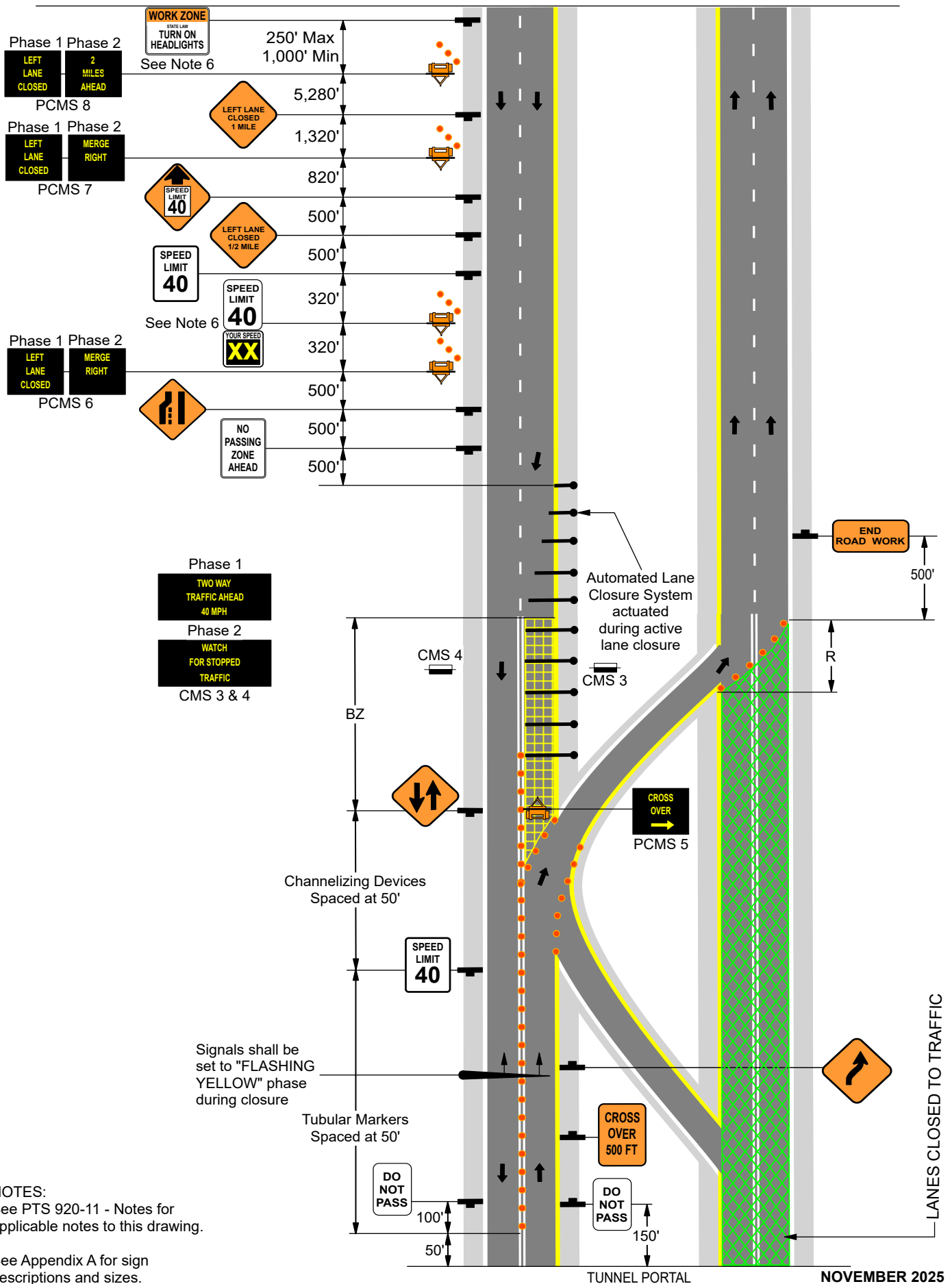

NOTES:
See PTS 920-11 - Notes for applicable notes to this drawing.

See Appendix A for sign descriptions and sizes.

TUNNEL PORTAL

NOVEMBER 2025

PTS 920-12 - Notes Blue Mountain / Kittatinny Tunnel Crossover Pattern

1. Use existing "DO NOT CROSS CENTER LINE" sign and existing traffic control signal at portal.
2. Use channelizing devices with PennDOT approved sequential warning lights in the taper areas for patterns used during hours of darkness.
3. Tunnel crossover pattern will not be permitted when all lanes are required to be available in accordance with the allowable working hours or the specified holiday restrictions.
4. Utilize existing CMS and place one (1) PCMS in each direction 1/2 mile to 1 mile in advance of the lane closure when utilizing the Tunnel Crossover Pattern with the following Message:

Phase 1:	Phase 2:
TRUCKS	NARROW
USE	LANE IN
CAUTION	TUNNEL

PCMS not required for PTC Maintenance Operations.

5. During high traffic volume periods and as directed by the Representative, change the message on the PCMS to read: PCMS 1 and 8 - Phase 1 "USE / BOTH / LANES", Phase 2 "TO / MERGE / POINT"; PCMS 2 - Phase 1 "RIGHT / LANE / CLOSED", Phase 2 "USE / BOTH / LANES"; PCMS 3 - Phase 1 "RIGHT / LANE / CLOSED", Phase 2 "MERGE / LEFT / 1500 FT"; PCMS 7 - Phase 1 "LEFT / LANE / CLOSED", Phase 2 "USE / BOTH / LANES"; PCMS 6 - Phase 1 "LEFT / LANE / CLOSED", Phase 2 "MERGE / RIGHT / 1500 FT".

6. R22-1 and Speed Display signs are not required for PTC Maintenance Department Operation.

Signs

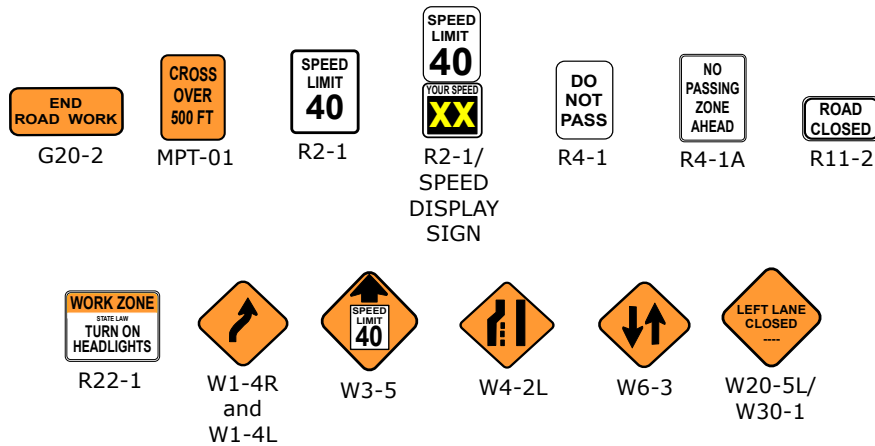

NOTE: See Appendix A for sign descriptions and dimensions.

Distance and Spacing Quick Reference Chart

SPEED	BZ	R	Maximum Channelizing Device Spacing (Feet)	
			BZ	R
MPH	Feet	Feet		
55	1,320 (Min)	100	50	20

R = Runout
BZ = Buffer Zone

PTS 920-12
Blue Mountain / Kittatinny Tunnel Crossover Pattern

TRAFFIC CONTROL BETWEEN
BLUE MOUNTAIN AND KITTATINNY TUNNELS

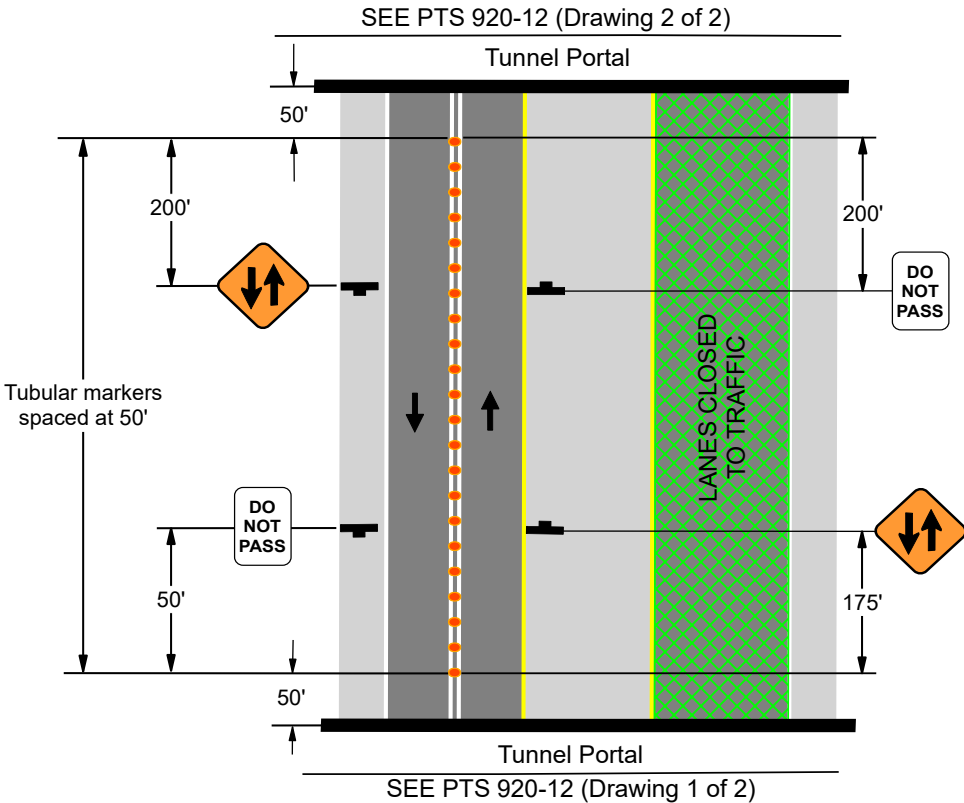

PTS 920-12

Blue Mountain / Kittatinny Tunnel Crossover Pattern (Drawing 2 of 2)

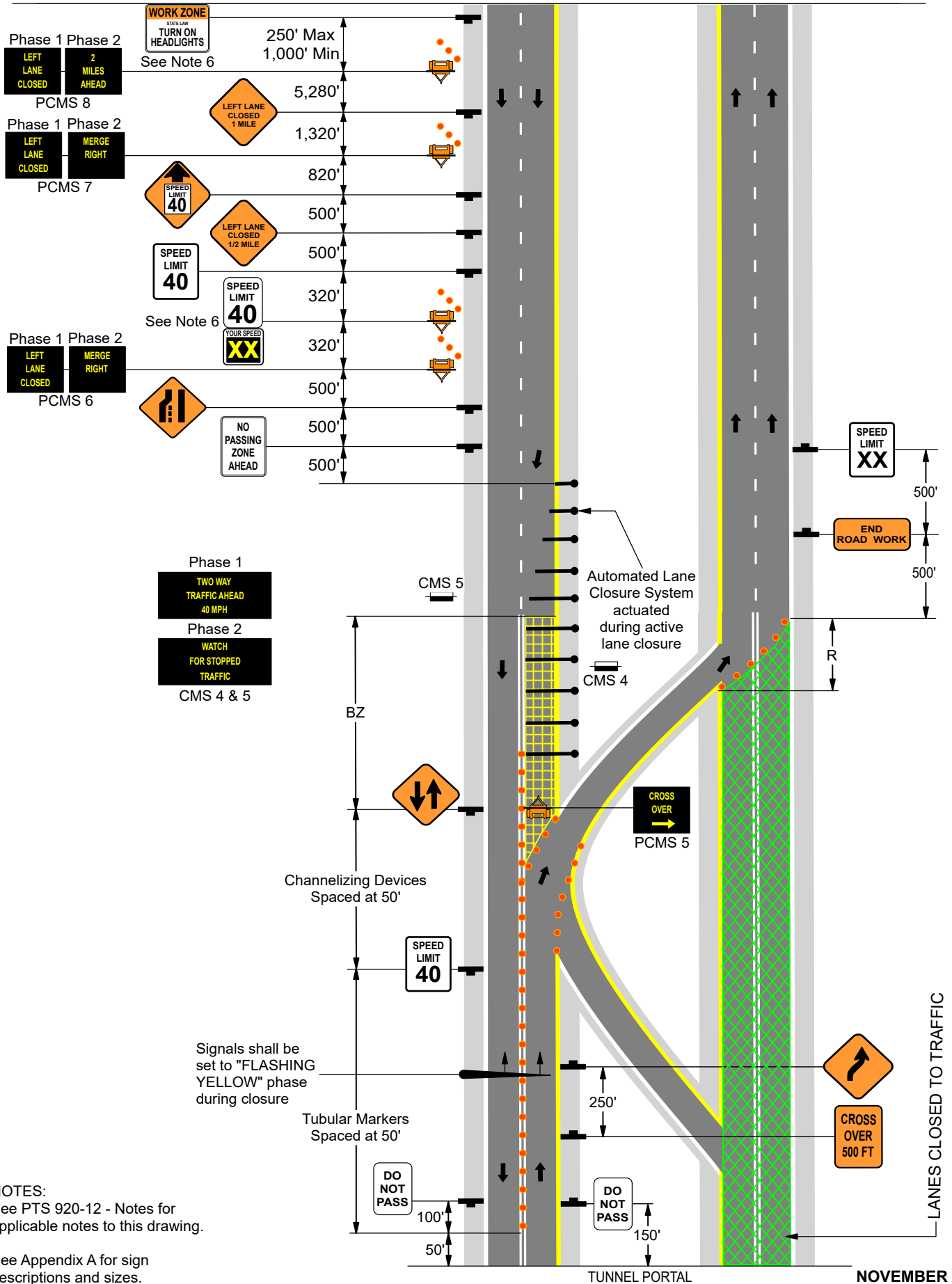

NOTES:
See PTS 920-12 - Notes for applicable notes to this drawing.

See Appendix A for sign descriptions and sizes.

PTS 920-13 - Notes Lehigh Tunnel Crossover Pattern

1. Use existing "DO NOT CROSS CENTER LINE" sign and existing traffic control signal at portal.
2. Use channelizing devices with PennDOT approved sequential warning lights in the taper areas for patterns used during hours of darkness.
3. Tunnel crossover pattern will not be permitted when all lanes are required to be available in accordance with the allowable working hours or the specified holiday restrictions.
4. Utilize existing CMS and place one (1) PCMS in each direction 1/2 mile to 1 mile in advance of the lane closure when utilizing the Tunnel Crossover Pattern with the following Message:

Phase 1:	Phase 2:
TRUCKS	NARROW
USE	LANE IN
CAUTION	TUNNEL

PCMS not required for PTC Maintenance Operations.

5. During high traffic volume periods and as directed by the Representative, change the message on the PCMS to read: PCMS 1 and 8 - Phase 1 "USE / BOTH / LANES", Phase 2 "TO / MERGE / POINT"; PCMS 2 - Phase 1 "LEFT / LANE / CLOSED", Phase 2 "USE / BOTH / LANES"; PCMS 3 - Phase 1 "LEFT / LANE / CLOSED", Phase 2 "MERGE / RIGHT / 1500 FT"; PCMS 7 - Phase 1 "LEFT / LANE / CLOSED", Phase 2 "USE / BOTH / LANES"; PCMS 6 - Phase 1 "LEFT / LANE / CLOSED", Phase 2 "MERGE / RIGHT / 1500 FT".

6. Compute the minimum desirable merging taper length for reduction in lanes using the following formula:

$$L = S_N \times W$$

Where L = Minimum desirable merging taper length in feet

W = Width of offset in feet

S_N = Normal speed limit in miles per hour

7. R22-1 and Speed Display signs are not required for PTC Maintenance Department Operation.

Signs

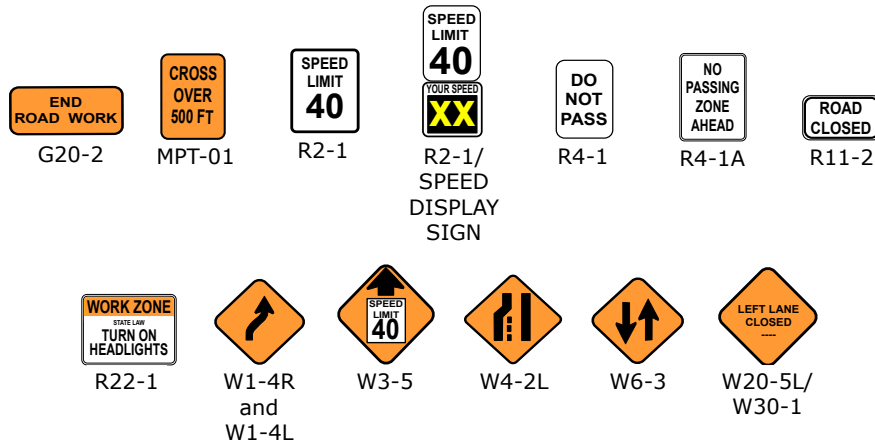

NOTE: See Appendix A for sign descriptions and dimensions.

Distance and Spacing Quick Reference Chart

SPEED	L	1/3 L	BZ	R	Maximum Channelizing Device Spacing (Feet)			
					L	1/3 L	BZ	R
MPH	Feet	Feet	Feet	Feet	L	1/3 L	BZ	R
55	660	220	1,320 (Min)	100	50	50	100	20

L = Merging Taper
 1/3L = Shoulder Taper
 BZ = Buffer Zone
 R = Runout

PTS 920-13 Lehigh Tunnel Crossover Pattern (Drawing 1 of 2)

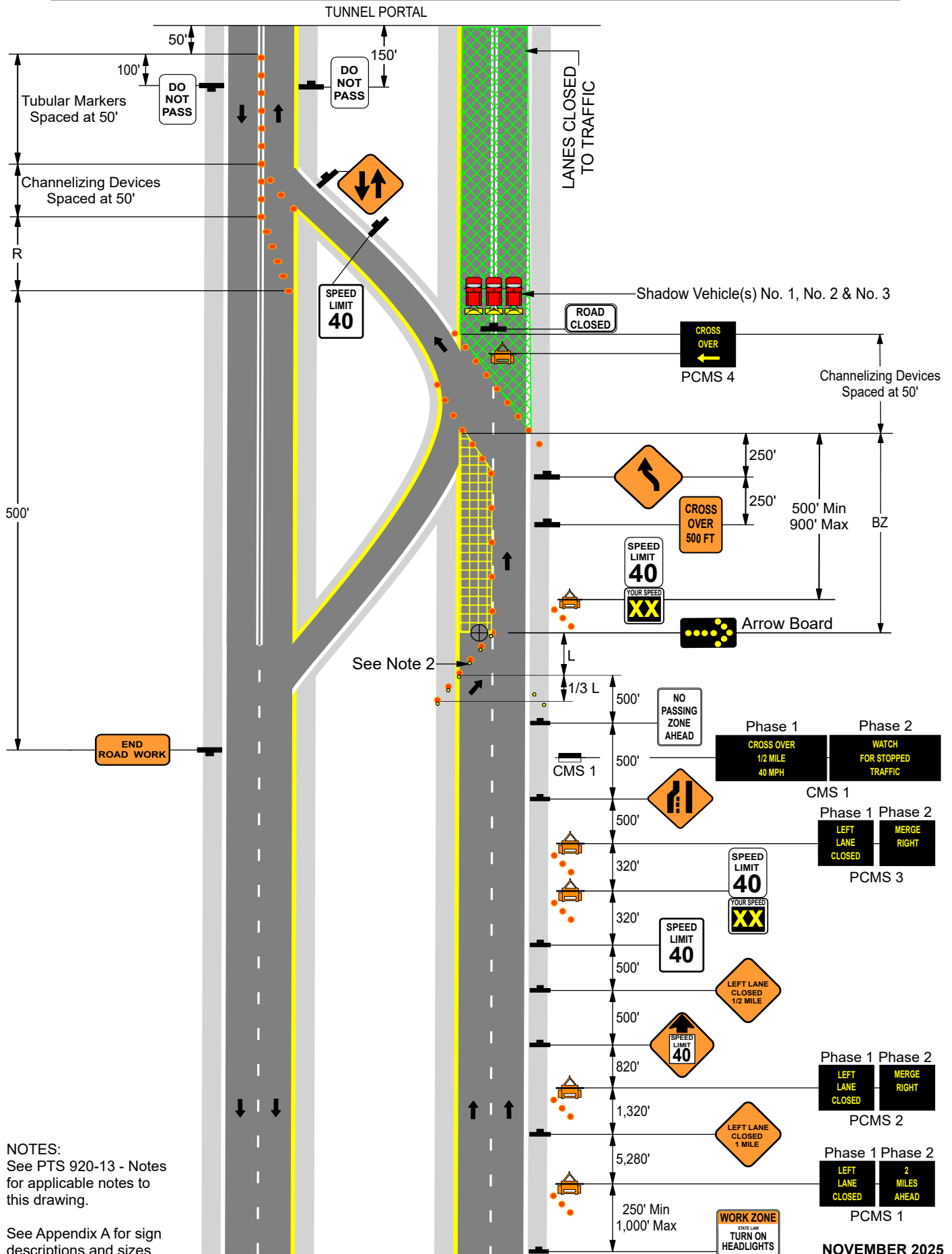

NOTES:
See PTS 920-13 - Notes for applicable notes to this drawing.

See Appendix A for sign descriptions and sizes.

PTS 920-13 Lehigh Tunnel Crossover Pattern (Drawing 2 of 2)

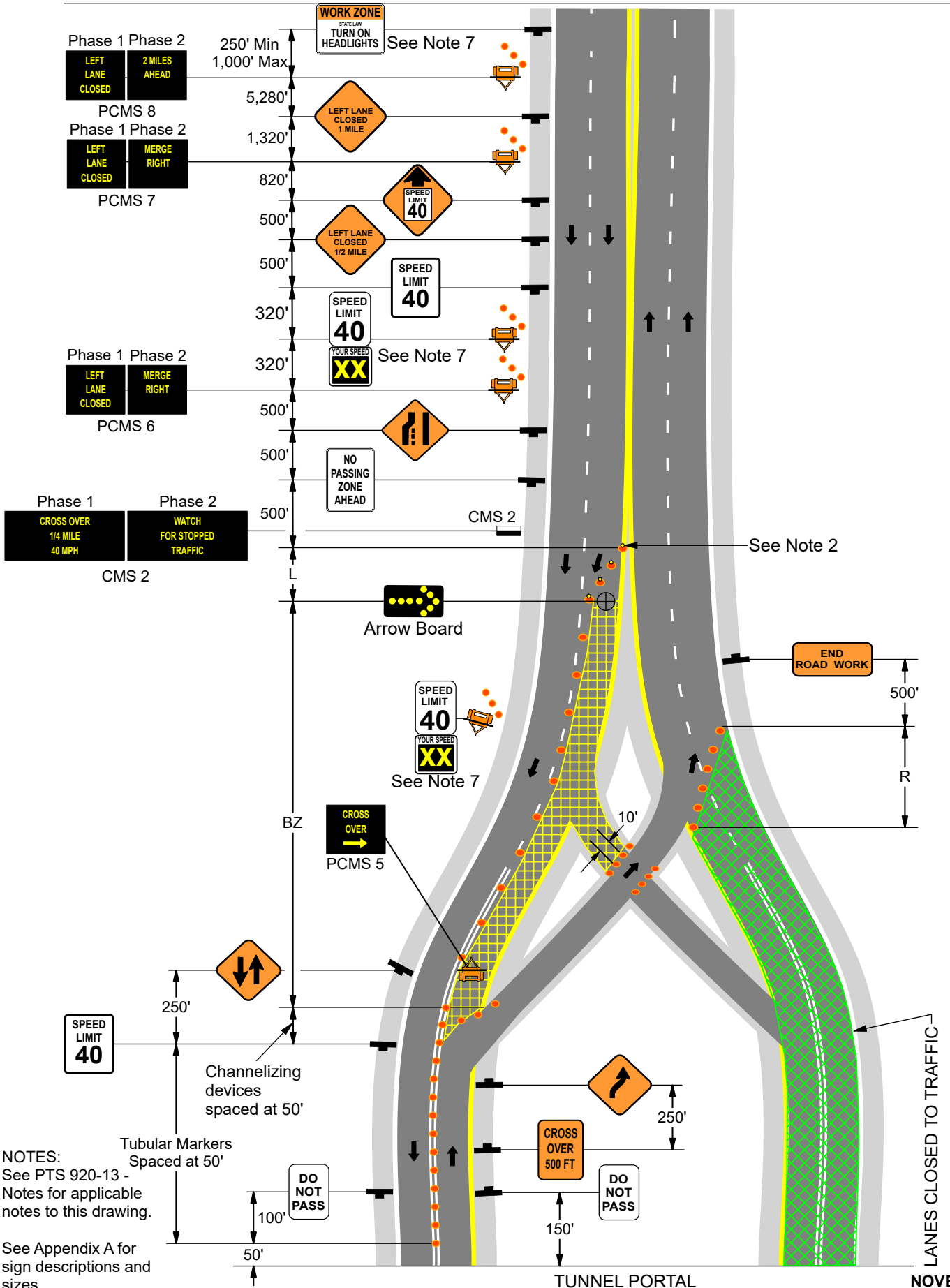

NOTES:
See PTS 920-13 -
Notes for applicable
notes to this drawing.

See Appendix A for
sign descriptions and
sizes.

PTS 920-14 - Notes Survey Work Along Shoulder

1. Vehicles, equipment, material and workers are not to be located in the buffer zone.
2. The figure applies when the survey work is a minimum of 15 minutes.
3. The survey work on shoulder operation may be used on the median shoulder where the median shoulder width is a minimum of 12 feet.
4. For any survey operation where workers are within two (2) feet of any travel lane, use Single Lane Closure with Channelizing Devices per PTS 920-3. Single lane closure with channelizing devices will not be permitted when all lanes are required to be available in accordance with the allowable working hours or the specified holiday restrictions.
5. Signs shall be mounted on PennDOT approved portable x-frame supports that are tested and approved for MASH Test Level 3 criteria, with a minimum height of 1 foot from the pavement surface to the bottom of the signs.

Signs

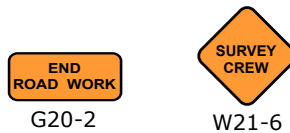

NOTE: See Appendix A for sign descriptions and dimensions.

PTS 920-14 Survey Work Along Shoulder

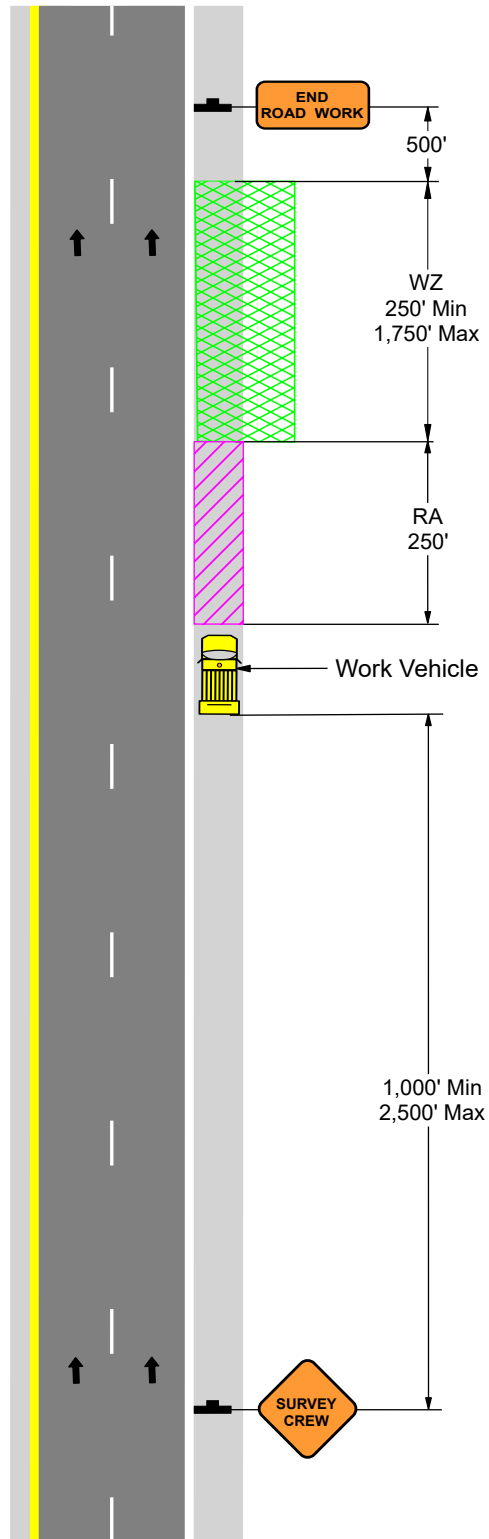

NOTES:
See PTS 920-14 - Notes for applicable notes to this drawing.

See Appendix A for sign descriptions and sizes.

PTS 920-15 - Notes

Utility Work Along Shoulder

1. Vehicles, equipment, material and workers are not to be located in the buffer zone.
2. The utility work along shoulder operation may be used on the median shoulder where the median shoulder width is a minimum of 12 feet.
3. Channelizing devices to remain in place until work is complete. Maintain normal lanes of traffic.
4. For any utility work along shoulder operation where the physical work zone is on the paved shoulder, use Stationary Shoulder Closure with Channelizing Devices per PTS 920-2. Utility work along shoulder and stationary shoulder closure will not be permitted when all lanes are required to be available in accordance with the allowable working hours or the specified holiday restrictions.
5. All arrow boards are to be truck-mounted or trailer-mounted and attached to the truck and shall move with the associated shadow vehicle.
6. Signs shall be mounted on PennDOT approved x-frame supports that are tested and approved for MASH Test Level 3 criteria, with a minimum height of 1 foot from the pavement surface to the bottom of the signs.

Signs

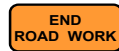

G20-2



W21-7

NOTE: See Appendix A for sign descriptions and dimensions.

PTS 920-15 Utility Work Along Shoulder

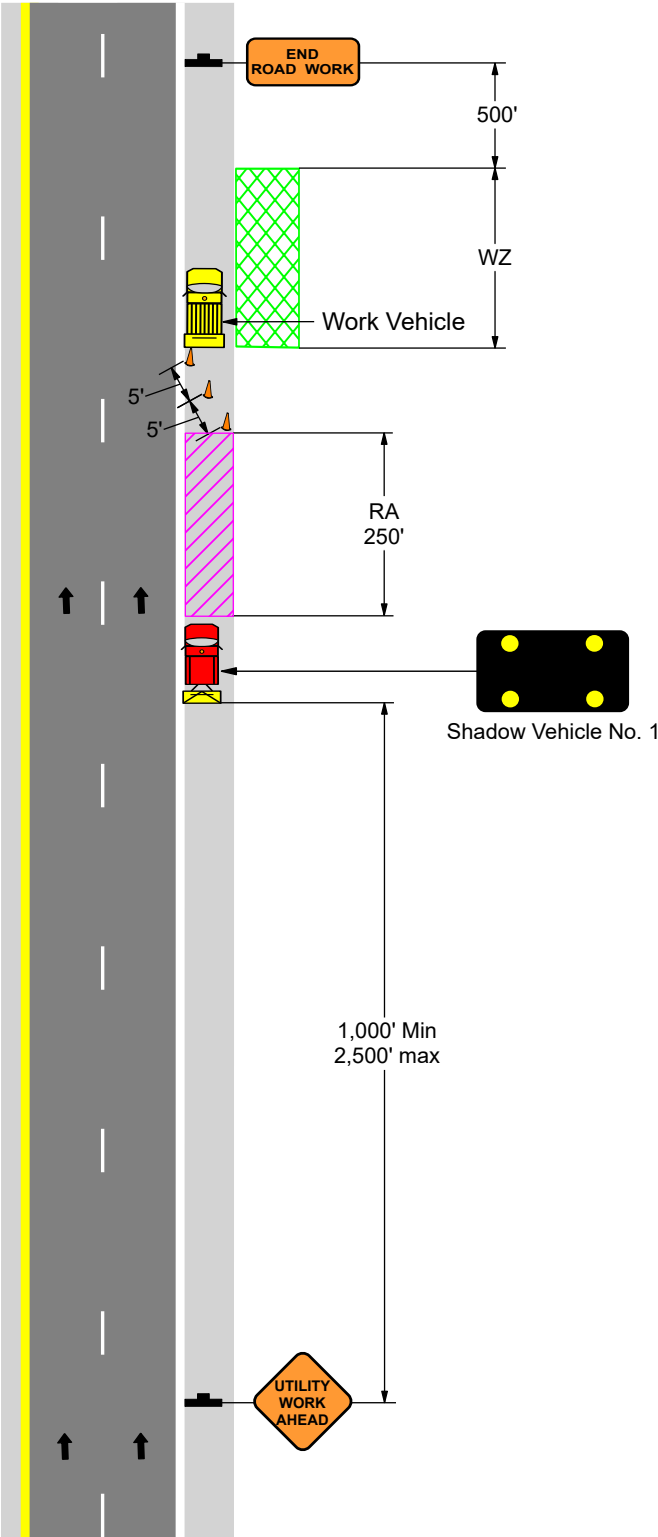

NOTES:
See PTS 920-15 - Notes for applicable notes to this drawing.

See Appendix A for sign descriptions and sizes.

Standards for Long-Term Operations

(PTS 930 Series)

PTS 930-1 - Notes General Notes

1. Remove all traffic control signs and devices immediately upon the completion of the work unless otherwise specified in the special provisions.
2. Place all traffic control devices and have them inspected by the Representative before work begins.
3. Maintain a minimum spacing of 200 feet between all regulatory, warning and destination signs.
4. Provide at minimum a 40 feet width beyond the edge of the travel lane free of obstacles. Drop-offs greater than 2 inches in depth in work zone(s) during non-working hours shall be separated from motorists with temporary barrier. Separation of work zone(s) is incidental to the MPT.
5. Details for the signs and devices can be found in these drawings, PennDOT Publication 236, PennDOT Publication 212 and are to be manufactured by a Department of Transportation approved manufacturer as listed in PennDOT Publication 35 (Bulletin 15).
6. Use PennDOT approved Type XI reflectorized material for signs.
7. These standards are not intended to relieve the Contractor of the responsibility for protection of the traveling public and construction personnel. Standards specified in Section 901.3(a) are minimum and additional measures may be needed if problems are encountered during the term of the contract.
8. Signs and devices may be adjusted to fit field conditions.
9. Concrete barrier details are to be according to PennDOT Standards for Roadway Construction, RC-57M, RC-59M, and PTC Standards for Roadway Construction.
10. Normal posted speed limit signs within advanced signing area prior to any W3-5 sign are to remain uncovered.
11. Cover or remove work zone speed limit signs when all normal lanes and all normal median and shoulder are available for the affected direction(s). Cover or remove work zone speed limit signs when temporary barrier closes the median or shoulder when the length of the physical work zone is less than 1 mile.
12. Only traffic control devices are permitted within the buffer zone. Do not locate vehicles, equipment, material, or workers in this area.
13. Type B light is to be mounted on the side closest to traffic as shown on PTS-980.
14. Type B yellow flashing warning lights may be used in conjunction with warning signs, unless otherwise indicated on the drawing.

PTS 930-2 - Notes

Stationary Shoulder Closure with Channelizing Devices

1. Channelizing devices to remain in place until work is completed. Maintain normal lanes of traffic.
 2. For median operations where the median shoulder is less than 12 feet wide, use Single Lane Closure with Channelizing Devices per PTS 930-3, left lane closed. Single lane closure traffic pattern shall remain in place until work is completed.
- For left shoulder work zone, use the same spacing, location, and pattern but with the signs indicating a left shoulder closure.
3. Install W3-5 sign only in areas where the normal speed limit is 70 MPH.
 4. All arrow boards are to be truck-mounted or trailer-mounted and attached to the truck and shall move with the associated shadow vehicle.
 5. Compute the minimum desirable shoulder taper length (1/3L) using the following formula:

$$L = S_N \times W$$
 Where L = Minimum desirable merging taper length in feet
 W = Width of offset in feet
 S_N = Normal speed limit in miles per hour
 6. Stationary shoulder closure with channelizing devices will not be permitted when all lanes are required to be available in accordance with the allowable working hours or the specified holiday restrictions.
 7. For multiple stationary shoulder closures with temporary barrier located within 1 mile of each other, install advanced signing prior to the first stationary shoulder closure only, with distance displayed on the MPT-31 sign as the length from the beginning of the first stationary shoulder closure to the end of the last stationary shoulder closure. The G20-2 sign is to be installed after the last stationary shoulder closure.
 8. MPT-31 sign shall only be used if the length of the physical work zone is greater than 1 mile.
 9. If active work is being performed at multiple locations throughout the physical work zone, consider the use of additional Shadow Vehicles(s) with Truck Mounted Attenuator prior to each work location. These additional vehicles are incidental to MPT.

Signs

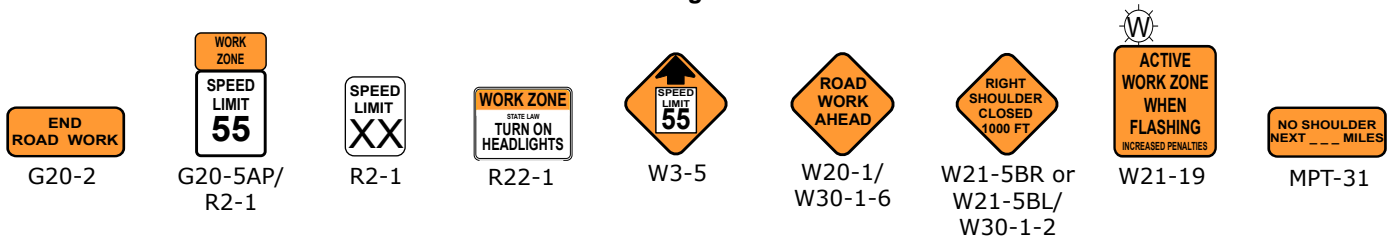

NOTE: See Appendix A for sign descriptions and dimensions.

Distance and Spacing Quick Reference Chart

SPEED	1/3 L	BZ	RA	WZ	R	Maximum Channelizing Device Spacing (Feet)		
						1/3 L	BZ, RA & WZ	R
MPH	Feet	Feet	Feet	Mile(s)	Feet			
55	220	250 (Min)	250	4 (Max)	100	50	100	20
70	280	250 (Min)	250	4 (Max)	100	50	100	20

1/3L = Shoulder Taper
 BZ = Buffer Zone
 RA = Roll Ahead Space
 WZ = Work Zone
 R = Runout

PTS 930-2A Stationary Shoulder Closure with Channelizing Devices

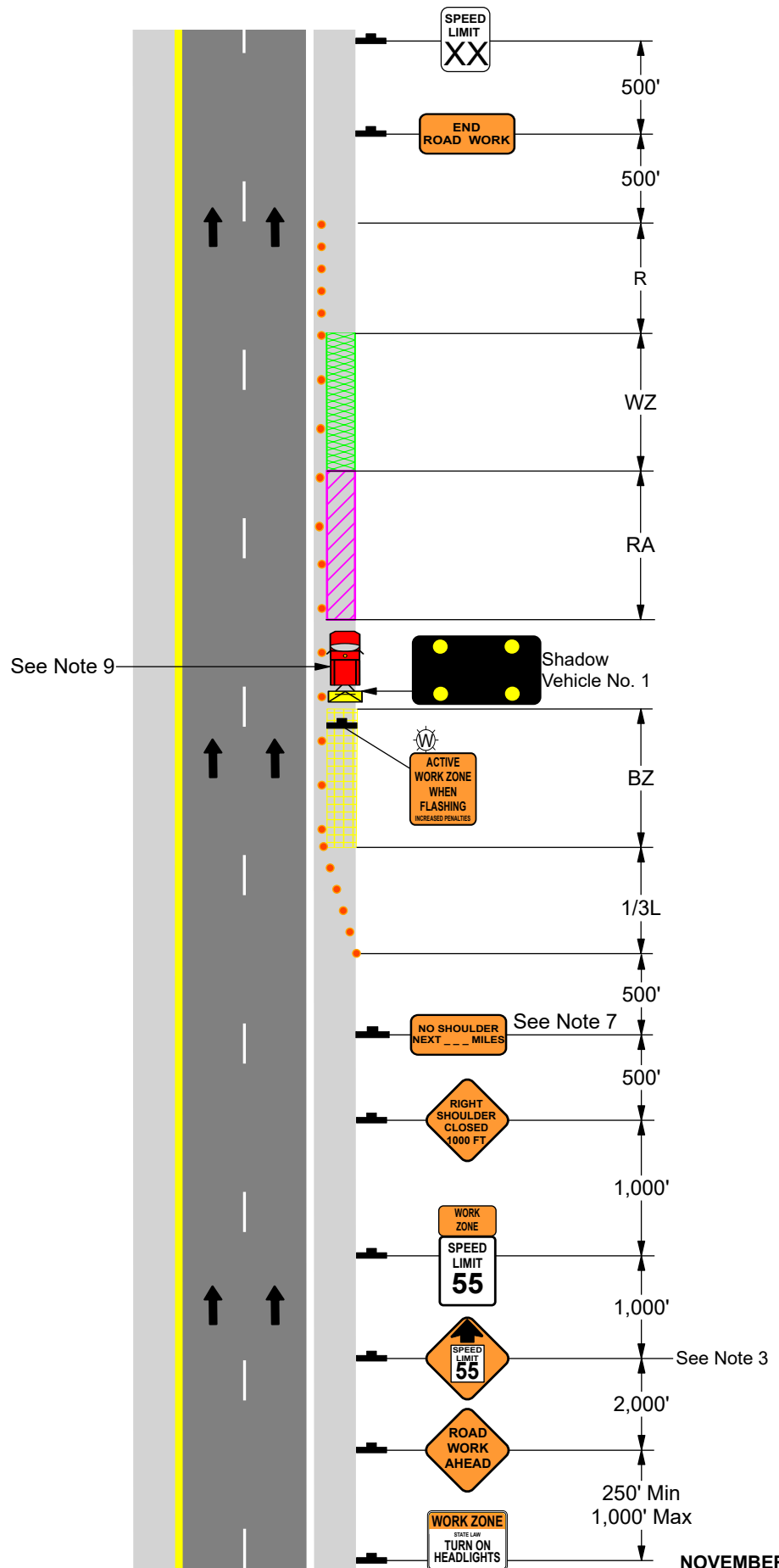

NOTES:
See PTS 930-2 - Notes for applicable notes to this drawing.

See Appendix A for sign descriptions and sizes.

PTS 930-2B Stationary Shoulder Closure with Channelizing Devices

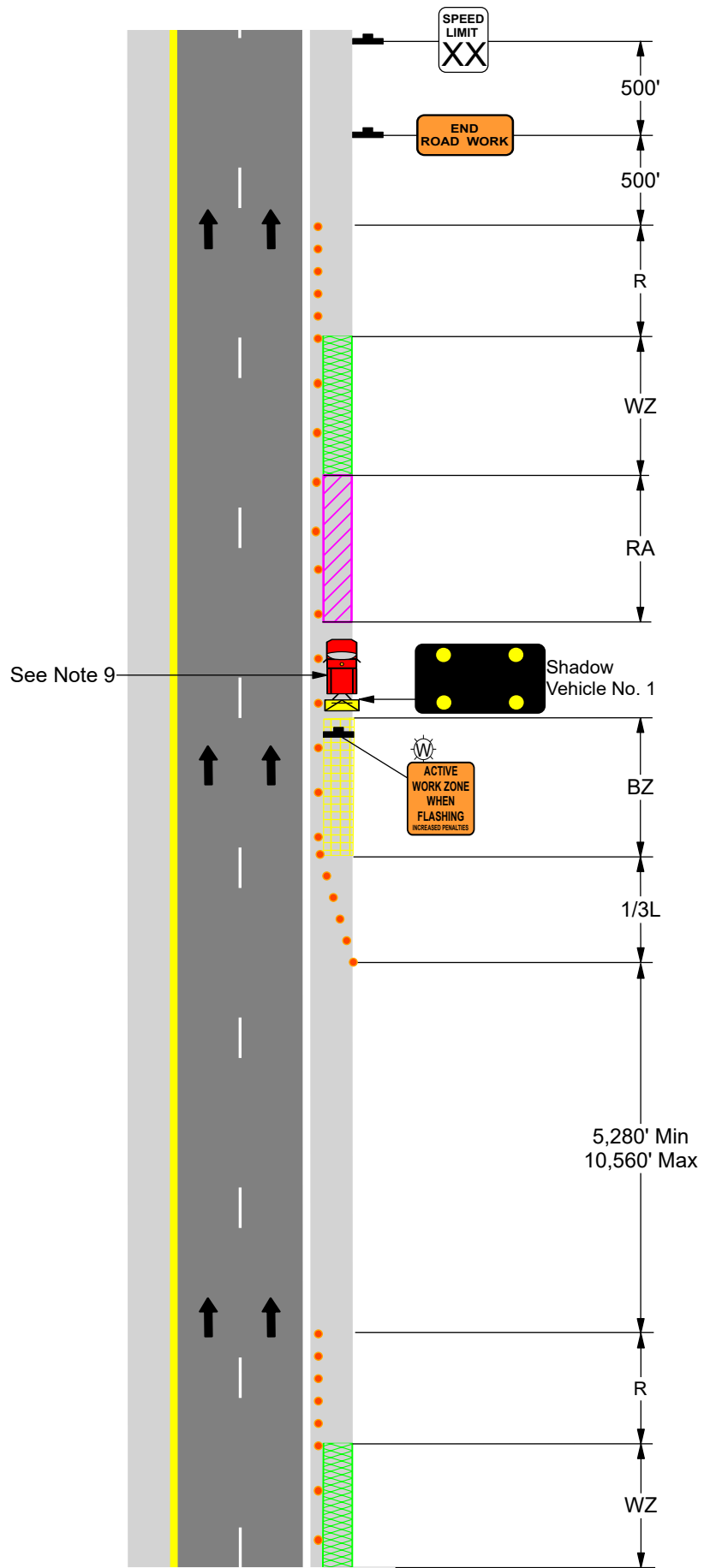

NOTES:
See PTS 930-2 - Notes for applicable notes to this drawing.

See Appendix A for sign descriptions and sizes.

See PTS 930-2A for Advance Signing

NOVEMBER 2025

PTS 930-3 - Notes

Single Lane Closure with Channelizing Devices

1. For interchange and service plaza ramp signing within the work zone, see PTS 930-7.
2. For left lane work zone, use the same sign spacing, location, and pattern but with the signs and PCMS indicating a left lane closure. Do not include arrow on Phase 2 of PCMS 3 with left lane closure.
3. Use channelizing devices with PennDOT approved sequential warning lights in the taper areas for patterns used during hours of darkness.
4. Single lane closure with channelizing devices will not be permitted when all lanes are required to be available in accordance with the allowable working hours or the specified holiday restrictions. Shorten length of single lane pattern to only the length needed for construction operation. Do not exceed a maximum physical work zone of four (4) miles in length.
5. Single lane shall be established a minimum of 1,000 feet in advance of deceleration ramp or beyond acceleration ramp at interchanges and service plazas, or as directed by the Representative.
6. Install W3-5 sign only in the areas where the normal speed limit is 70 MPH.
7. Speed Display Sign shall only be used if the length of the physical work zone is greater than or equal to 500 feet.
8. Compute the minimum desirable merging taper length for reduction in lanes using the following formula:

$$L = S_N \times W$$

Where L = Minimum desirable merging taper length in feet
 W = Width of offset in feet
 S_N = Normal speed limit in miles per hour
9. Additional arrow boards may be used in the closed lane(s) as long as they operate in Caution Mode.
10. For a three (3) lane section of roadway, use the same sign spacing, location, and pattern.
11. If active work is being performed at multiple locations throughout the physical work zone, consider the use of additional Shadow Vehicles(s) with Truck Mounted Attenuator prior to each work location. These additional vehicles are incidental to MPT.

Signs



NOTE: See Appendix A for sign descriptions and dimensions.

Distance and Spacing Quick Reference Chart

SPEED MPH	L Feet	1/3 L Feet	BZ Feet	RA Feet	WZ Mile(s)	R Feet	Maximum Channelizing Device Spacing (Feet)		
							L & 1/3L	BZ, RA & WZ	R
55	660	220	500 (Min)	250	4 (Max)	100	50	100	20
70	840	280	750 (Min)	250	4 (Max)	100	50	100	20

L = Merging Taper
 1/3L = Shoulder Taper
 BZ = Buffer Zone
 RA = Roll Ahead Space
 WZ = Work Zone

PTS 930-3 Single Lane Closure with Channelizing Devices

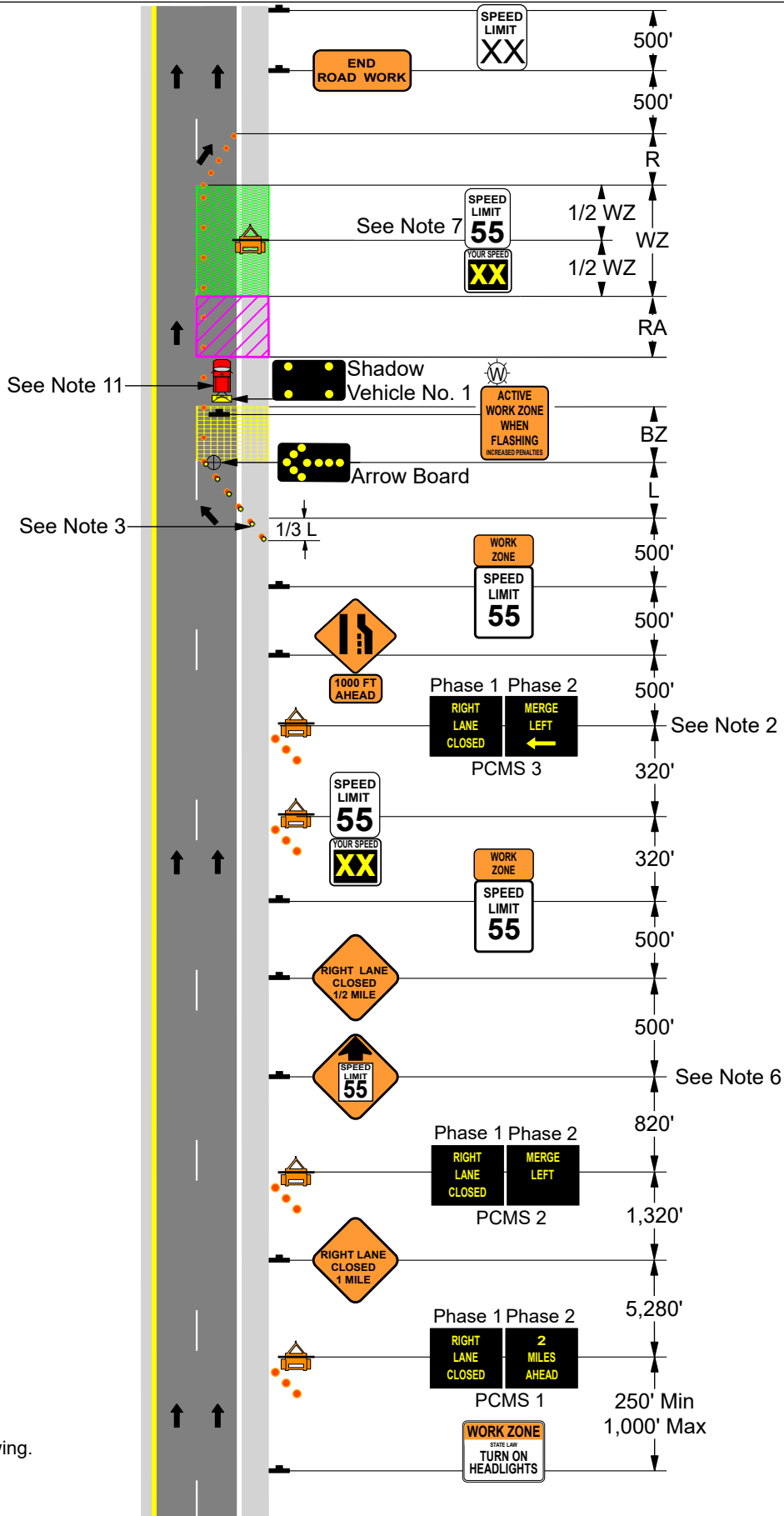

NOTES:
See PTS 930-3 - Notes for applicable notes to this drawing.

See Appendix A for sign descriptions and sizes.

PTS 930-4 - Notes Dual Lane Closure with Channelizing Devices

1. For interchange and service plaza signing within the work zone, see PTS 930-7.
2. For left and center lane work zone, use the same spacing, location, and pattern but with the signs and PCMS indicating a left and center lane closure. Do not include arrow on Phase 2 of PCMS 3 with left and center lane closure.
3. Use channelizing devices with PennDOT approved sequential warning lights in the taper areas for patterns used during hours of darkness.
4. Dual lane closure with channelizing devices will not be permitted when all lanes are required to be available in accordance with the allowable working hours or the specified holiday restrictions. Shorten length of single lane pattern to only the length needed for the construction operation. Do not exceed a maximum physical work zone of four (4) miles in length.
5. Single lane shall be established a minimum of 1,000 feet in advance of deceleration ramp or beyond acceleration ramp at interchanges and service plazas, or as directed by the Representative.
6. Install W3-5 sign only in areas where the normal speed limit is 70 MPH.
7. Speed Display Sign shall only be used if the length of the physical work zone is greater than or equal to 500 feet.
8. Compute the minimum desirable merging taper length for reduction in lanes using the following formula:

$$L = S_N \times W$$
 Where L = Minimum desirable merging taper length in feet
 W = Width of offset in feet
 S_N = Normal speed limit in miles per hour
9. Additional arrow boards may be used in the closed lane(s) as long as they operate in Caution Mode.
10. If active work is being performed at multiple locations throughout the physical work zone, consider the use of additional Shadow Vehicles(s) with Truck Mounted Attenuator prior to each work location. These additional vehicles are incidental to MPT.

Signs

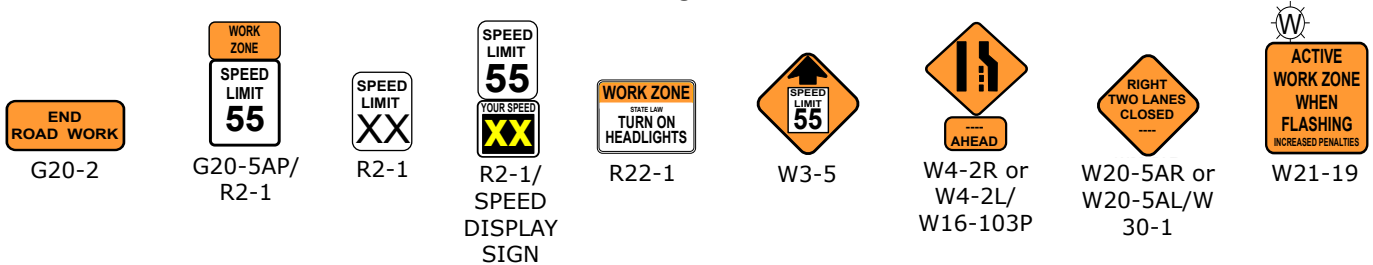

NOTE: See Appendix A for sign descriptions and dimensions.

Distance and Spacing Quick Reference Chart

SPEED	L	1/3 L	BZ 1	BZ 2	RA	WZ	R	Maximum Channelizing Device Spacing (Feet)		
								L & 1/3L	BZ 1, BZ 2, RA & WZ	R
MPH	Feet	Feet	Feet	Feet	Feet	Mile(s)	Feet			
55	660	220	1,320 (Min)	500 (Min)	250	4 (Max)	100	50	100	20
70	840	280	1,680 (Min)	750 (Min)	250	4 (Max)	100	50	100	20

- L = Merging Taper
- 1/3 L = Shoulder Taper
- BZ 1 = Buffer Zone 1
- BZ 2 = Buffer Zone 2
- RA = Roll Ahead Zone
- WZ = Work Zone
- R = Runout

PTS 930-4 Dual Lane Closure with Channelizing Devices

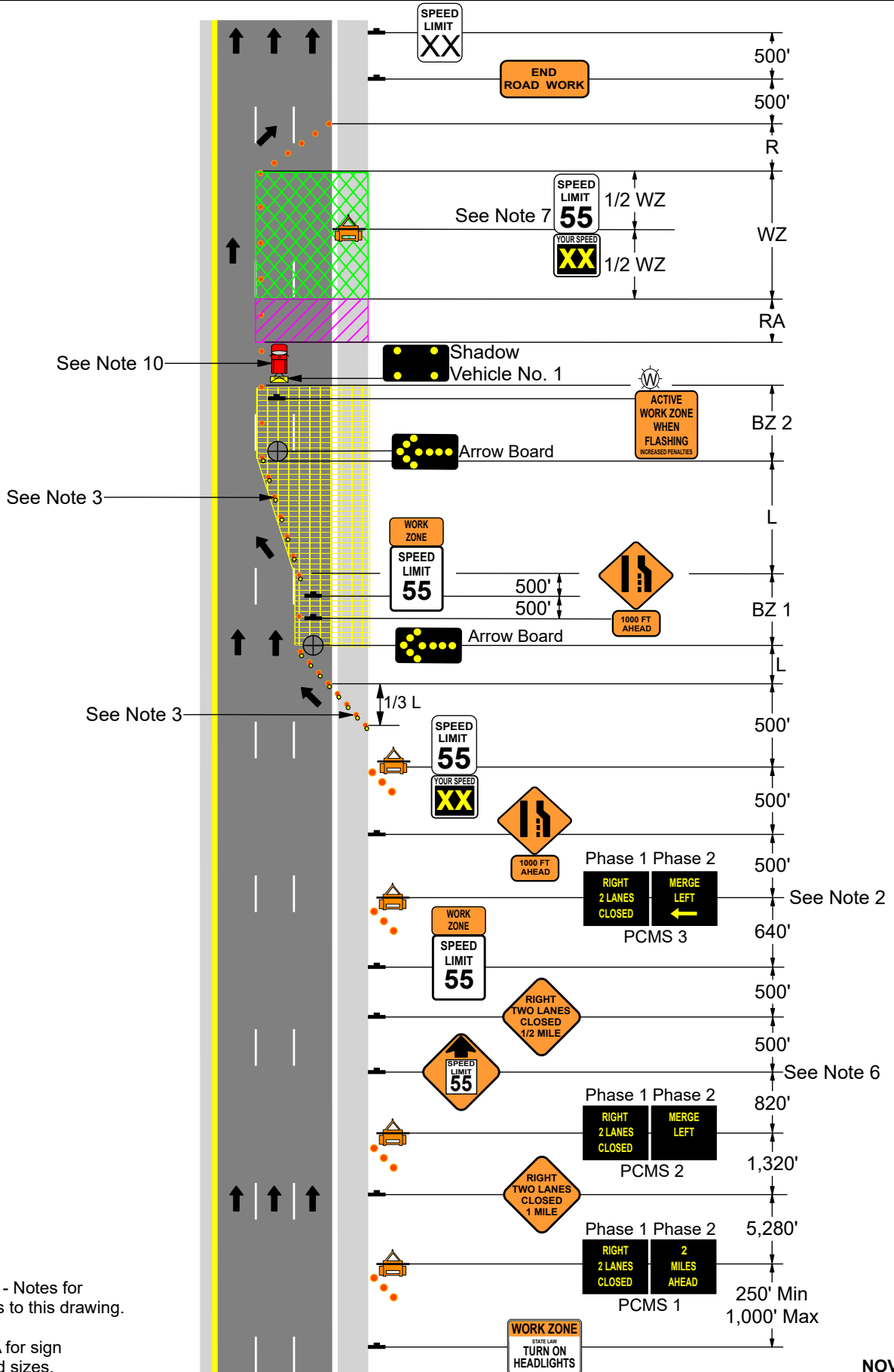

NOTES:
See PTS 930-4 - Notes for applicable notes to this drawing.

See Appendix A for sign descriptions and sizes.

PTS 930-5 - Notes

Right Lane Closure within Transition from 2 to 3 Lanes

1. For interchange and service plaza ramp signing within the work zone, see PTS 930-7.
2. Right lane closure within transition from 2 to 3 lanes will not be permitted when all lanes are required to be available in accordance with the allowable working hours or the specified holiday restrictions. Shorten length of pattern to only the length needed for the construction operation. Do not exceed a maximum physical work zone of four (4) miles in length.
3. Install W3-5 sign only in areas where the normal speed limit is 70 mph.
4. Speed Display Sign shall only be used if the length of the physical work zone is greater than or equal to 500 feet.
5. Compute the minimum desirable shoulder taper length (1/3L) for reduction in lanes using the following formula:

$$L = S_N \times W$$
 Where L = Minimum desirable taper length in feet
 W = Width of offset in feet
 S_N = Normal speed limit in miles per hour
6. Additional arrow boards may be used in the closed lane(s) as long as they operate in Caution Mode.
7. If active work is being performed at multiple locations throughout the physical work zone, consider the use of additional Shadow Vehicles(s) with Truck Mounted Attenuator prior to each work location. These additional vehicles are incidental to MPT.

Signs

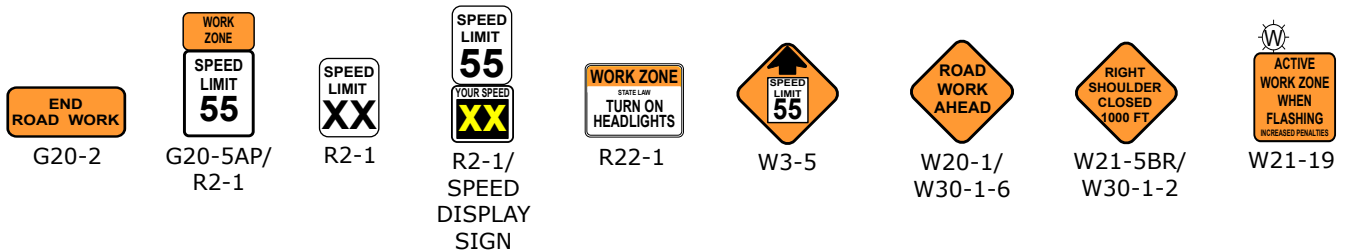

NOTE: See Appendix A for sign descriptions and dimensions.

Distance and Spacing Quick Reference Chart

SPEED	1/3 L	BZ	RA	WZ	R	Maximum Channelizing Device Spacing (Feet)		
						1/3 L	BZ, RA & WZ	R
MPH	Feet	Feet	Feet	Mile(s)	Feet	1/3 L	BZ, RA & WZ	R
55	220	500 (Min)	250	4 (Max)	100	50	100	20
70	280	750 (Min)	250	4 (Max)	100	50	100	20

1/3L = Shoulder Taper
 BZ = Buffer Zone
 RA = Roll Ahead Space
 WZ = Work Zone
 R = Runout

PTS 930-5 Right Lane Closure within Transition from 2 to 3 Lanes

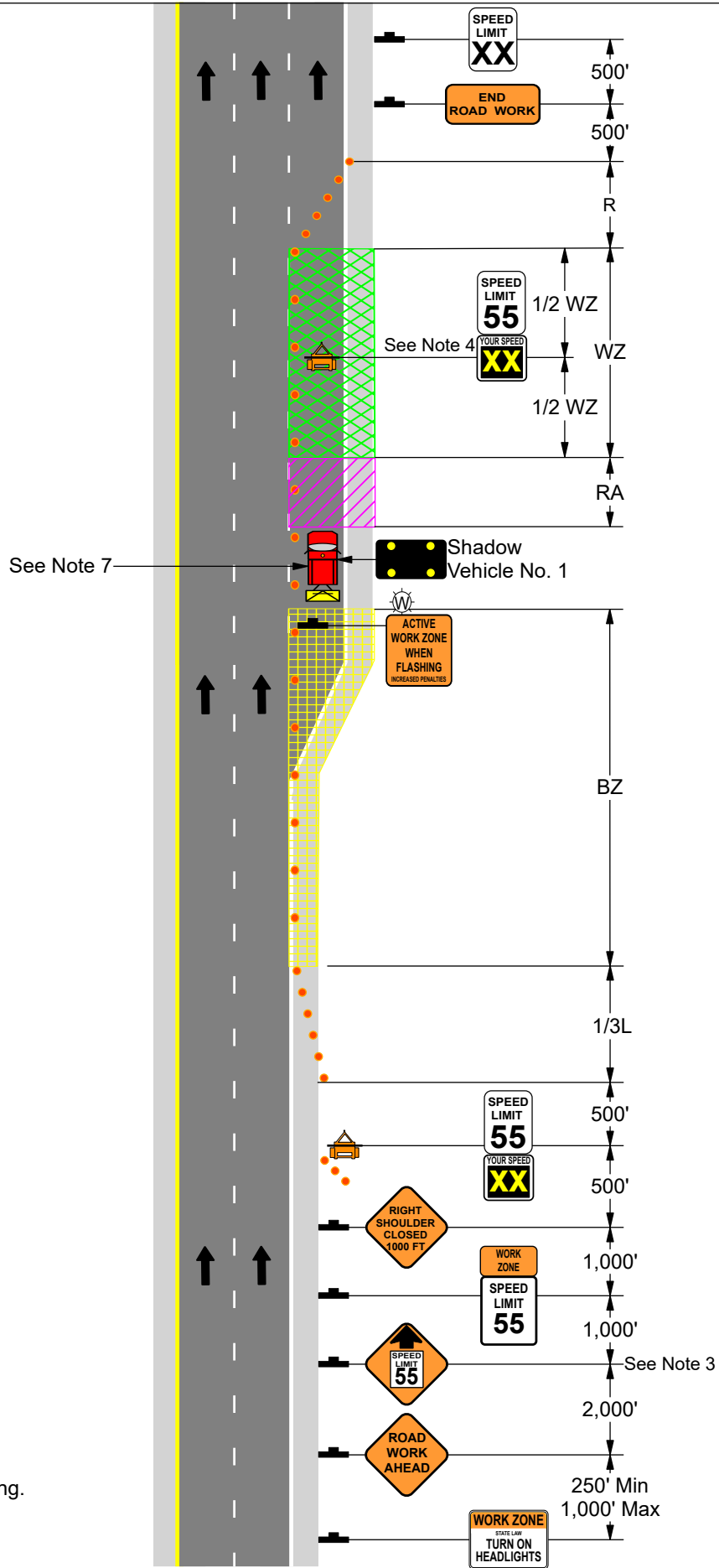

NOTES:
See PTS 930-5 - Notes for applicable notes to this drawing.
See Appendix A for sign descriptions and sizes.

PTS 930-6 - Notes

Center / Right Lane Closure within Transition from 2 to 3 Lanes

1. For interchange and service plaza ramp signing within the work zone, see PTS 930-7.
2. Use channelizing devices with PennDOT approved sequential warning lights in the taper area for patterns used during hours of darkness.
3. Center/Right lane closure within transition from 2 to 3 lanes will not be permitted when all lanes are required to be available in accordance with the allowable working hours or the specified holiday restrictions. Shorten length of pattern to only the length needed for the construction operation. Do not exceed a physical maximum work zone of four (4) miles in length.
4. Single lane shall be established a minimum of 1,000 feet in advance of deceleration ramp or beyond acceleration ramp at interchanges or service plazas, or as directed by the Representative.
5. Install W3-5 sign only in areas where the normal speed limit is 70 mph.
6. Speed Display Sign shall only be used if the length of the physical work zone is greater than or equal to 500 feet.
7. Compute the minimum merging taper length using the following formula:

$$L = S_N \times W$$
 Where L = Minimum desirable merging taper length in feet
 W = Width of offset in feet
 S_N = Normal speed limit in miles per hour
8. Additional arrow boards may be used in the closed lane(s) as long as they operate in Caution Mode.
9. If active work is being performed at multiple locations throughout the physical work zone, consider the use of additional Shadow Vehicles(s) with Truck Mounted Attenuator prior to each work location. These additional vehicles are incidental to MPT.

Signs

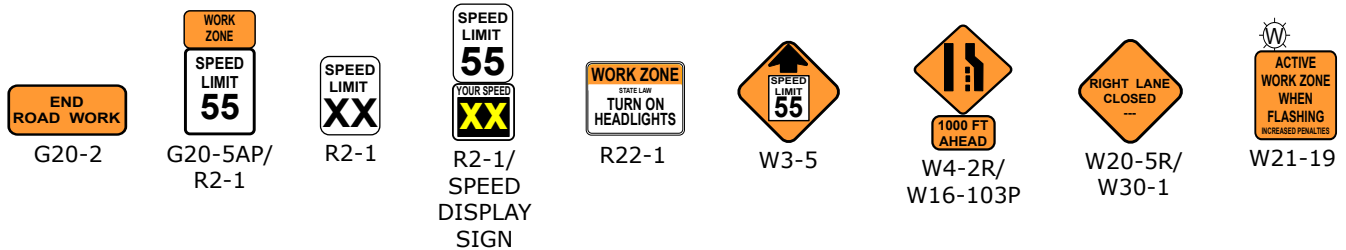

NOTE: See Appendix A for sign descriptions and dimensions.

Distance and Spacing Quick Reference Chart

SPEED MPH	L Feet	1/3 L Feet	BZ Feet	RA Feet	WZ Mile(s)	R Feet	Maximum Channelizing Device Spacing (Feet)		
							L & 1/3L	BZ, RA & WZ	R
55	660	220	500 (Min)	250	4 (Max)	100	50	100	20
70	840	280	750 (Min)	250	4 (Max)	100	50	100	20

L = Merging Taper
 1/3L = Shoulder Taper
 BZ = Buffer Zone
 RA = Roll Ahead Space
 WZ = Work Zone
 R = Runout

PTS 930-6 Center / Right Lane Closure within Transition from 2 to 3 Lanes

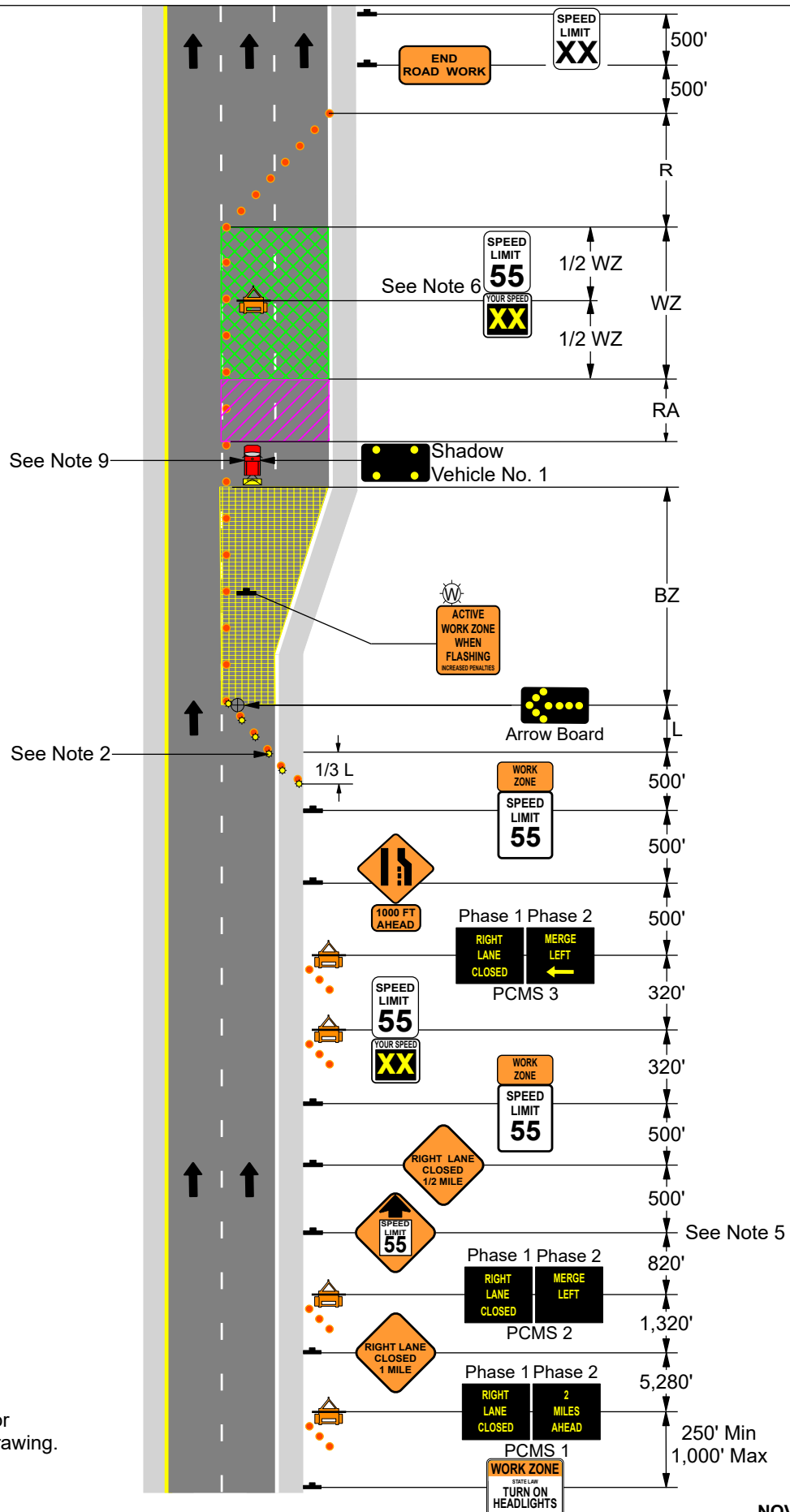

NOTES:
See PTS 930-6 - Notes for applicable notes to this drawing.

See Appendix A for sign descriptions and sizes.

PTS 930-7 - Notes

Lane Closure Traffic Pattern for Interchange and Service Plaza Areas

1. Single lane shall be established per PTS 930-3 or PTS 930-4 a minimum of 1,000 feet in advance of deceleration ramp or beyond acceleration ramp at interchanges and service plazas or as directed by the Representative.
2. MPT-06 sign:
 - A. Use for interchange ramp only.
 - B. Cover or remove from the site when not in use.
3. MPT-08 sign:
 - A. Use for service plaza ramp only.
 - B. Cover or remove from the site when not in use.
4. Lane closure traffic pattern for interchange and service plaza areas will not be permitted when all lanes are required to be available in accordance with the allowable working hours or specified holiday restrictions.
5. Channelizing devices spaced at 100 feet except where noted.
6. Space signs evenly at 200 feet minimum spacing, or as conditions warrant.
7. Display Exit Number or Service Plaza Name on Phase 1 of PCMS if space allows.
8. PCMS is incidental to MPT.
9. PTS 930-7A, Lane Closure Traffic Pattern for Interchange and Service Plaza Areas with Yield Control, to be used unless work zone is in the right lane and within 1,080' of beginning of acceleration lane. If 780' of acceleration lane and 300' of taper cannot be provided use PTS 930-7B, Lane Closure Traffic Pattern for Interchange and Service Plaza Areas with Stop Control.

Signs

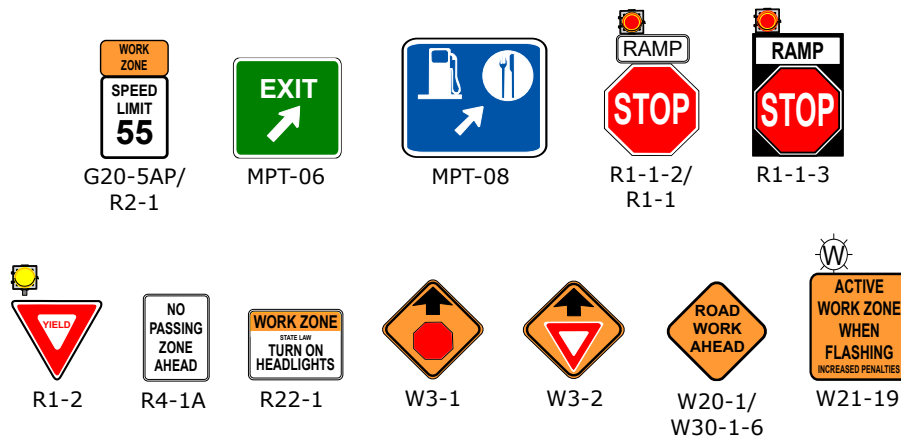

NOTE: See Appendix A for sign descriptions and dimensions.

PTS 930-7A Lane Closure Traffic Pattern for Interchange and Service Plaza Areas with Yield Control

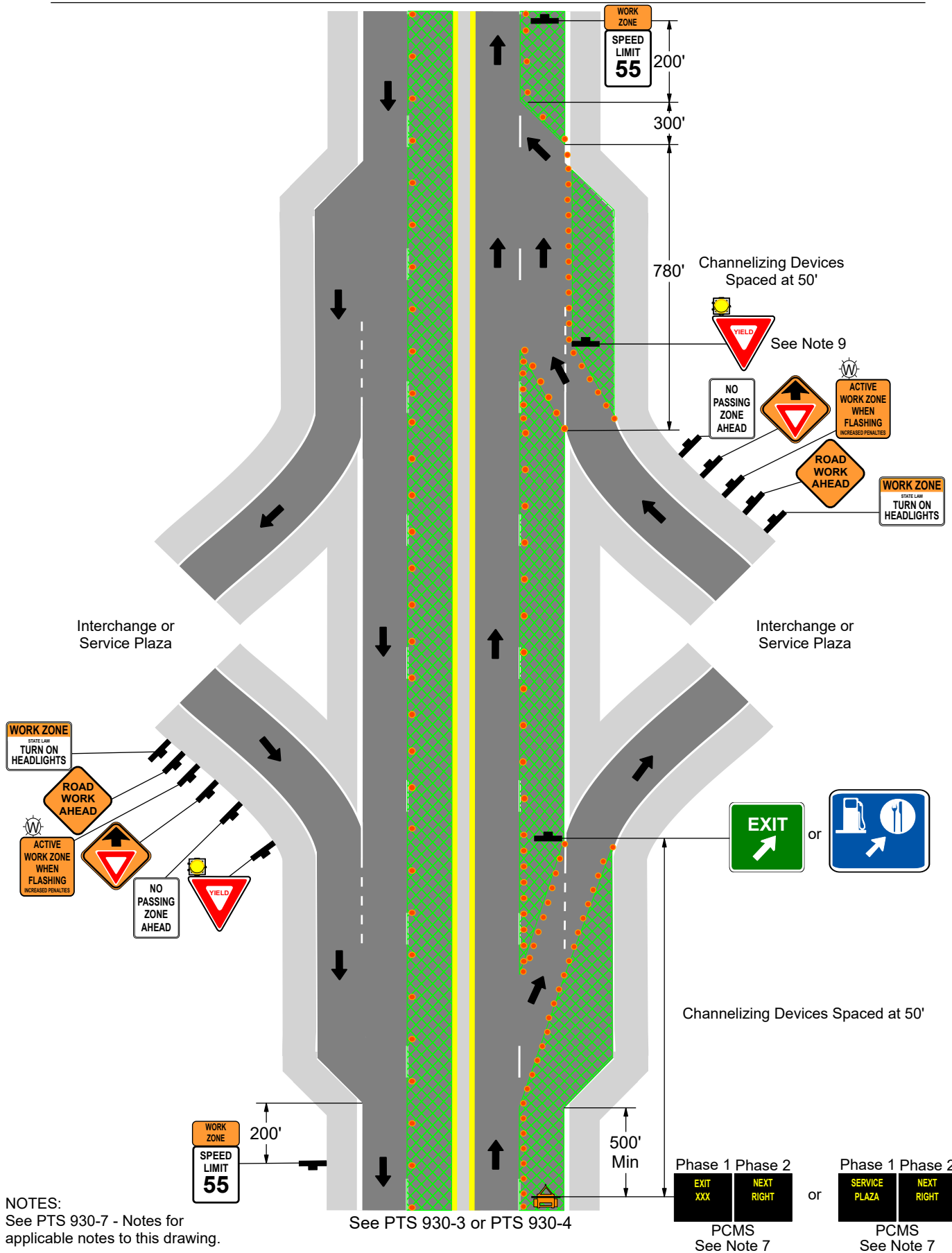

NOTES:
See PTS 930-7 - Notes for applicable notes to this drawing.

See Appendix A for sign descriptions and sizes.

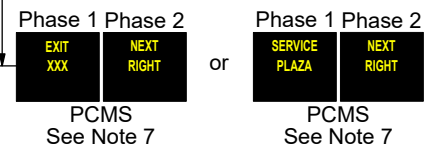

PTS 930-7B Lane Closure Traffic Pattern for Interchange and Service Plaza Areas with Stop Control

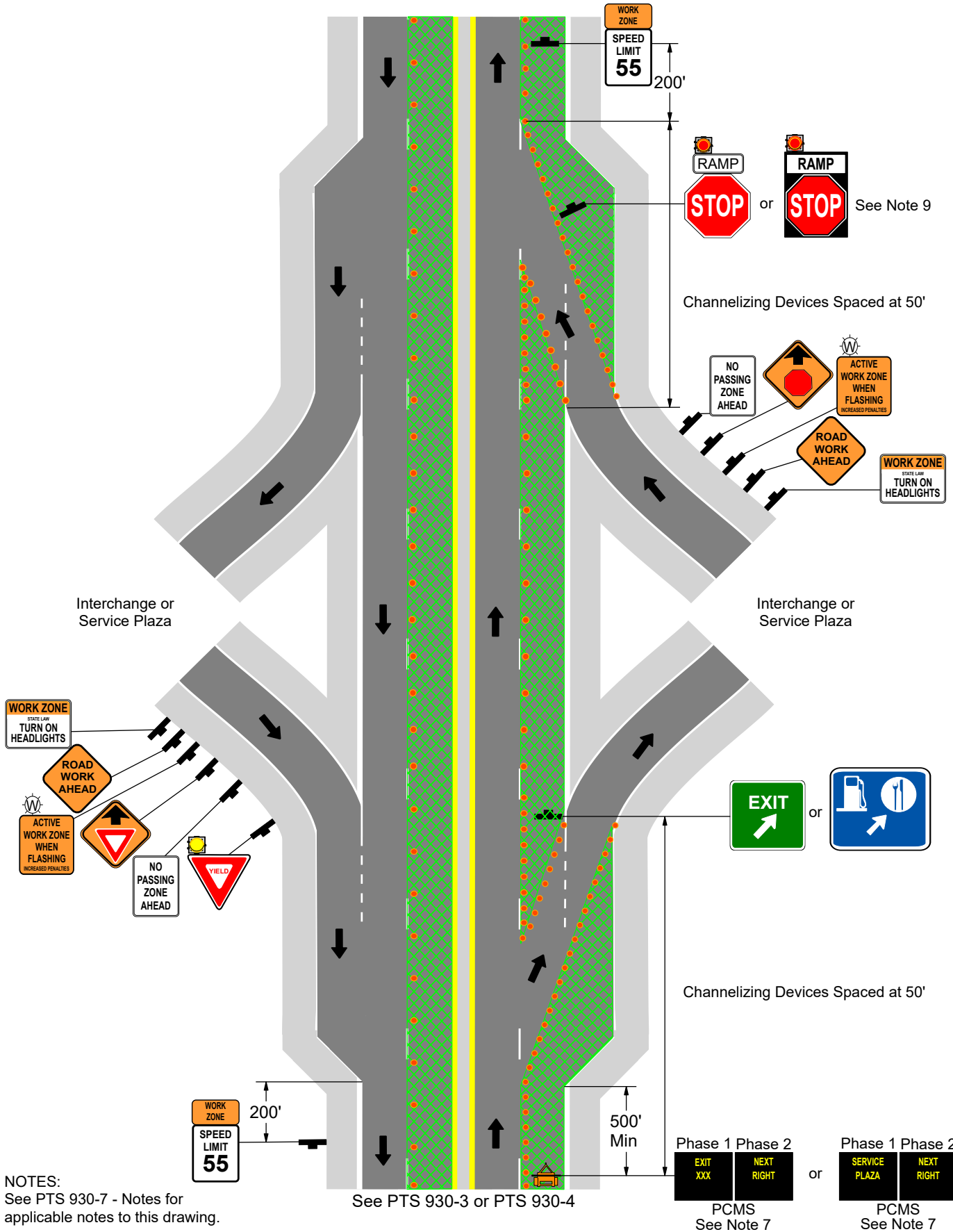

NOTES:
See PTS 930-7 - Notes for applicable notes to this drawing.

See Appendix A for sign descriptions and sizes.

PTS 930-8 - Notes

Multiple Single Lane Closure Traffic Patterns

1. For interchange and service plaza ramp signing within the work zone, see PTS 930-7.
2. For left lane work zone, use the same sign spacing, location and pattern but with the signs and PCMS indicating the left lane is closed. Do not include arrow on Phase 2 of PCMS 5 with left lane closure.
3. For advanced signing, see PTS 930-3.
4. Use channelizing devices with PennDOT approved sequential warning lights in the taper area for patterns used during hours of darkness.
5. Multiple traffic patterns will not be permitted when all lanes are required to be available in accordance with the available working hours or the specified holiday restrictions. Shorten length of single lane pattern to only the length needed for construction operation. Do not exceed a maximum physical work zone four (4) miles in length for each single lane traffic pattern.
6. Single lane shall be established a minimum of 1,000 feet in advance of deceleration ramp or beyond acceleration ramp at interchanges and service plazas, or as directed by the Representative.
7. Speed Display Sign shall only be used if the length of the physical work zone is greater than or equal to 500 feet.
8. Compute the minimum desirable merging taper length for reduction in lanes using the following formula:

$$L = S_N \times W$$

Where L = Minimum desirable merging taper length in feet
W = Width of offset in feet
S_N = Normal speed limit in miles per hour

9. If active work is being performed at multiple locations throughout the physical work zone, consider the use of additional Shadow Vehicles(s) with Truck Mounted Attenuator prior to each work location. These additional vehicles are incidental to MPT.

Signs

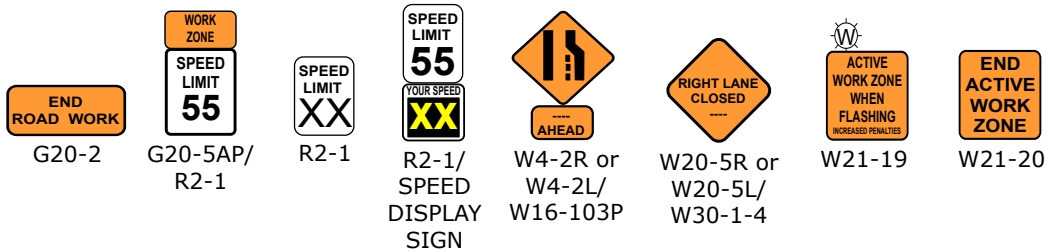

NOTE: See Appendix A for sign descriptions and dimensions.

Distance and Spacing Quick Reference Chart

SPEED MPH	L Feet	1/3 L Feet	BZ Feet	RA Feet	WZ Mile(s)	R Feet	Maximum Channelizing Device Spacing (Feet)		
							L & 1/3L	BZ, RA & WZ	R
55	660	220	500 (Min)	250	4 (Max)	100	50	100	20
70	840	280	750 (Min)	250	4 (Max)	100	50	100	20

L = Merging Taper
1/3L = Shoulder Taper
BZ = Buffer Zone
RA = Roll Ahead Space
WZ = Work Zone
R = Runout

PTS 930-8 Multiple Single Lane Closure Traffic Patterns

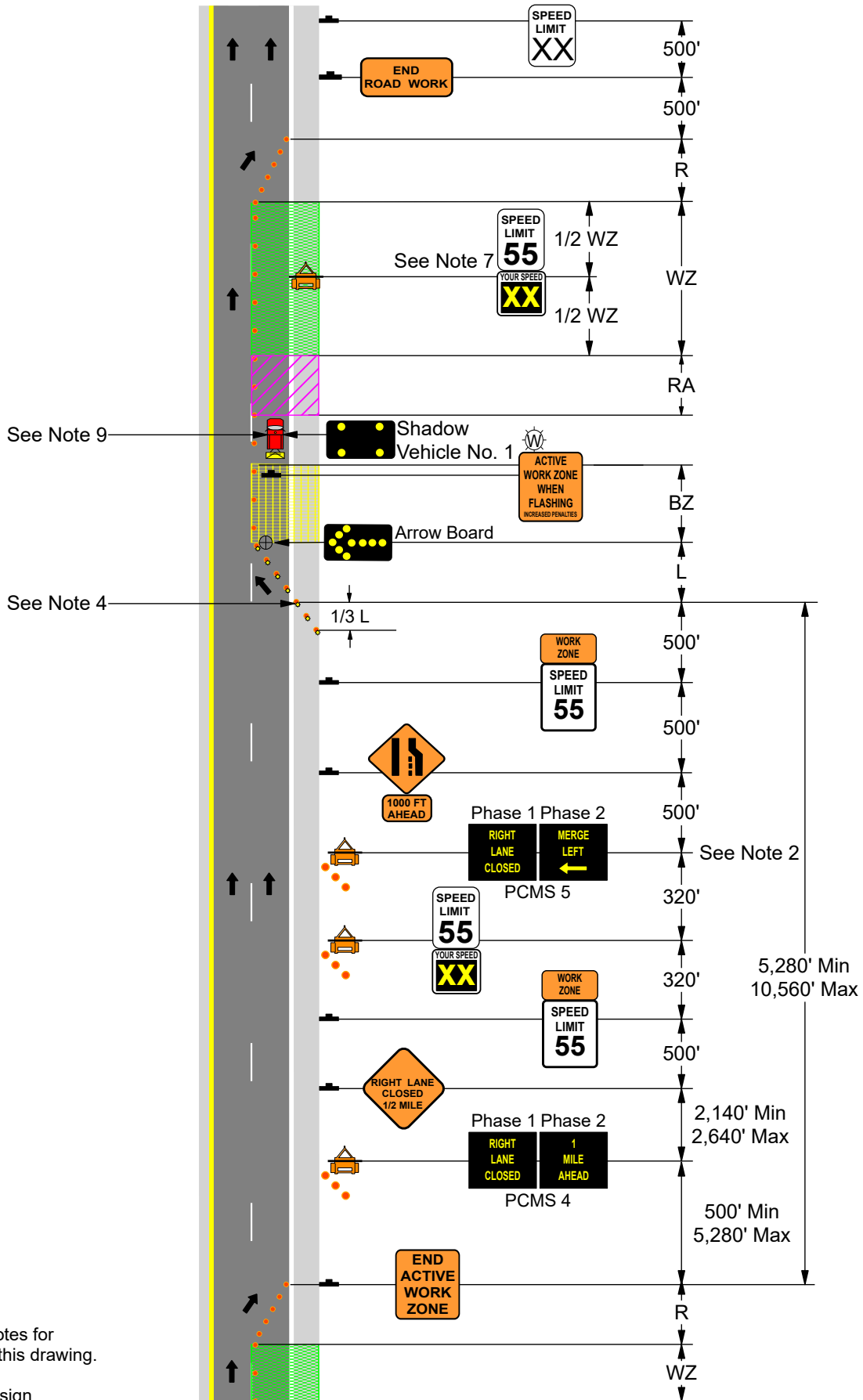

NOTES:
See PTS 930-8 - Notes for applicable notes to this drawing.

See Appendix A for sign descriptions and sizes.

SEE PTS 930-3

PTS 930-9 - Notes

Multiple Dual Lane Closure Traffic Patterns

1. For interchange and service plaza ramp signing within the work zone, see PTS 930-7.
2. For left lane work zone, use the same sign spacing, location and pattern but with the signs and PCMS indicating the left lane is closed. Do not include arrow on Phase 2 of PCMS 5 with left lane closure.
3. For advanced signing, see PTS 930-4.
4. Use channelizing devices with PennDOT approved sequential warning lights in the taper area for patterns used during hours of darkness.
5. Multiple traffic patterns will not be permitted when all lanes are required to be available in accordance with the available working hours or the specified holiday restrictions. Shorten length of single lane pattern to only the length needed for construction operation. Do not exceed a maximum physical work zone four (4) miles in length for each dual lane traffic pattern.
6. Single lane shall be established a minimum of 1,000 feet in advance of deceleration ramp or beyond acceleration ramp at interchanges and service plazas, or as directed by the Representative.
7. Speed Display Sign shall only be used if the length of the physical work zone is greater than or equal to 500 feet.
8. Compute the minimum desirable merging taper length for reduction in lanes using the following formula:

$$L = S_N \times W$$

Where L = Minimum desirable merging taper length in feet
W = Width of offset in feet
S_N = Normal speed limit in miles per hour

9. If active work is being performed at multiple locations throughout the physical work zone, consider the use of additional Shadow Vehicles(s) with Truck Mounted Attenuator prior to each work location. These additional vehicles are incidental to MPT.

Signs

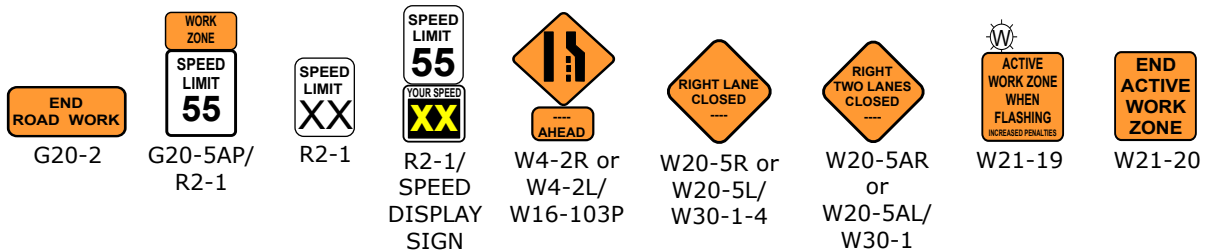

NOTE: See Appendix A for sign descriptions and dimensions.

Distance and Spacing Quick Reference Chart

SPEED	L	1/3 L	BZ 1	BZ 2	RA	WZ	R	Maximum Channelizing Device Spacing (Feet)		
								L & 1/3L	BZ 1, BZ 2, RA & WZ	R
55	660	220	1,320 (Min)	500 (Min)	250	4 (Max)	100	50	100	20
70	840	280	1,680 (Min)	750 (Min)	250	4 (Max)	100	50	100	20

L = Merging Taper
1/3L = Shoulder Taper
BZ 1 = Buffer Zone 1
BZ 2 = Buffer Zone 2
RA = Roll Ahead Space
WZ = Work Zone
R = Runout

PTS 930-9 Multiple Dual Lane Closure Traffic Patterns

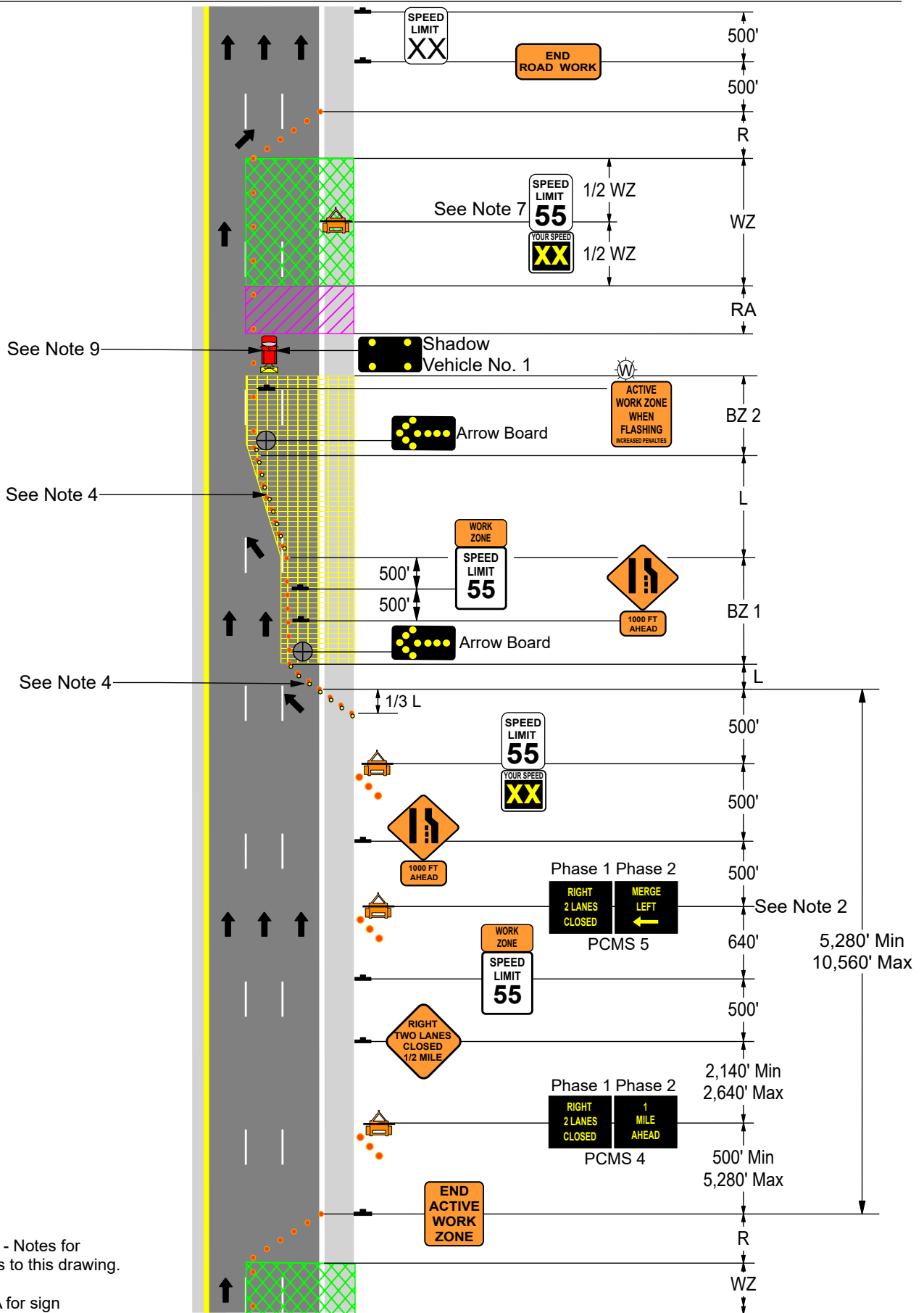

NOTES:
See PTS 930-9 - Notes for applicable notes to this drawing.

See Appendix A for sign descriptions and sizes.

SEE PTS 930-4

PTS 930-10 - Notes Allegheny Tunnel Crossover Pattern

1. Use existing "DO NOT CROSS CENTER LINE" sign and existing traffic control signal at portal.
2. Use channelizing devices with PennDOT approved sequential warning lights in the taper areas for patterns used during hours of darkness.
3. Tunnel crossover pattern will not be permitted when all lanes are required to be available in accordance with the allowable working hours or the specified holiday restrictions.
4. Utilize existing CMS and place one (1) PCMS in each direction 1/2 mile to 1 mile in advance of the lane closure when utilizing the Tunnel Crossover Pattern with the following message:

Phase 1:	Phase 2:
TRUCKS	NARROW
USE	LANE IN
CAUTION	TUNNEL

5. Compute the minimum desirable merging taper length for reduction in lanes using the following formula:

$$L = S_N \times W$$

Where L = Minimum desirable merging taper length in feet

W = Width of offset in feet

S_N = Normal speed limit in miles per hour

Signs

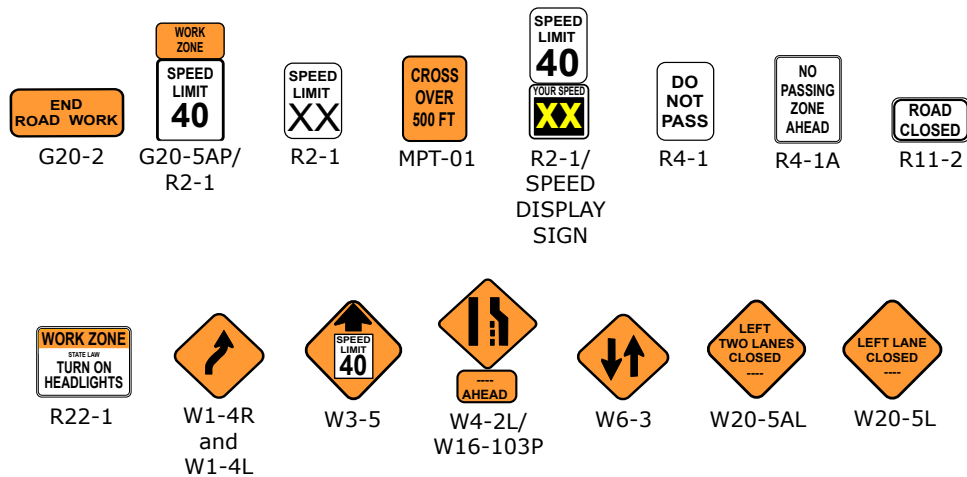

NOTE: See Appendix A for sign descriptions and dimensions.

Distance and Spacing Quick Reference Chart

SPEED	L	1/3 L	BZ 1	BZ 2	R	Maximum Channelizing Device Spacing (Feet)		
						L & 1/3L	BZ 1, BZ 2, RA & WZ	R
55	660	220	1,320 (Min)	500 (Min)	100	50	100	20

L = Merging Taper
 1/3 L = Shoulder Taper
 BZ 1 = Buffer Zone 1
 BZ 2 = Buffer Zone 2
 RA = Roll Ahead Space
 WZ = Work Zone
 R = Runout

PTS 930-10 Allegheny Tunnel Crossover Pattern (Drawing 1 of 3)

SEE PTS 930-10
(Drawing 2 of 3)

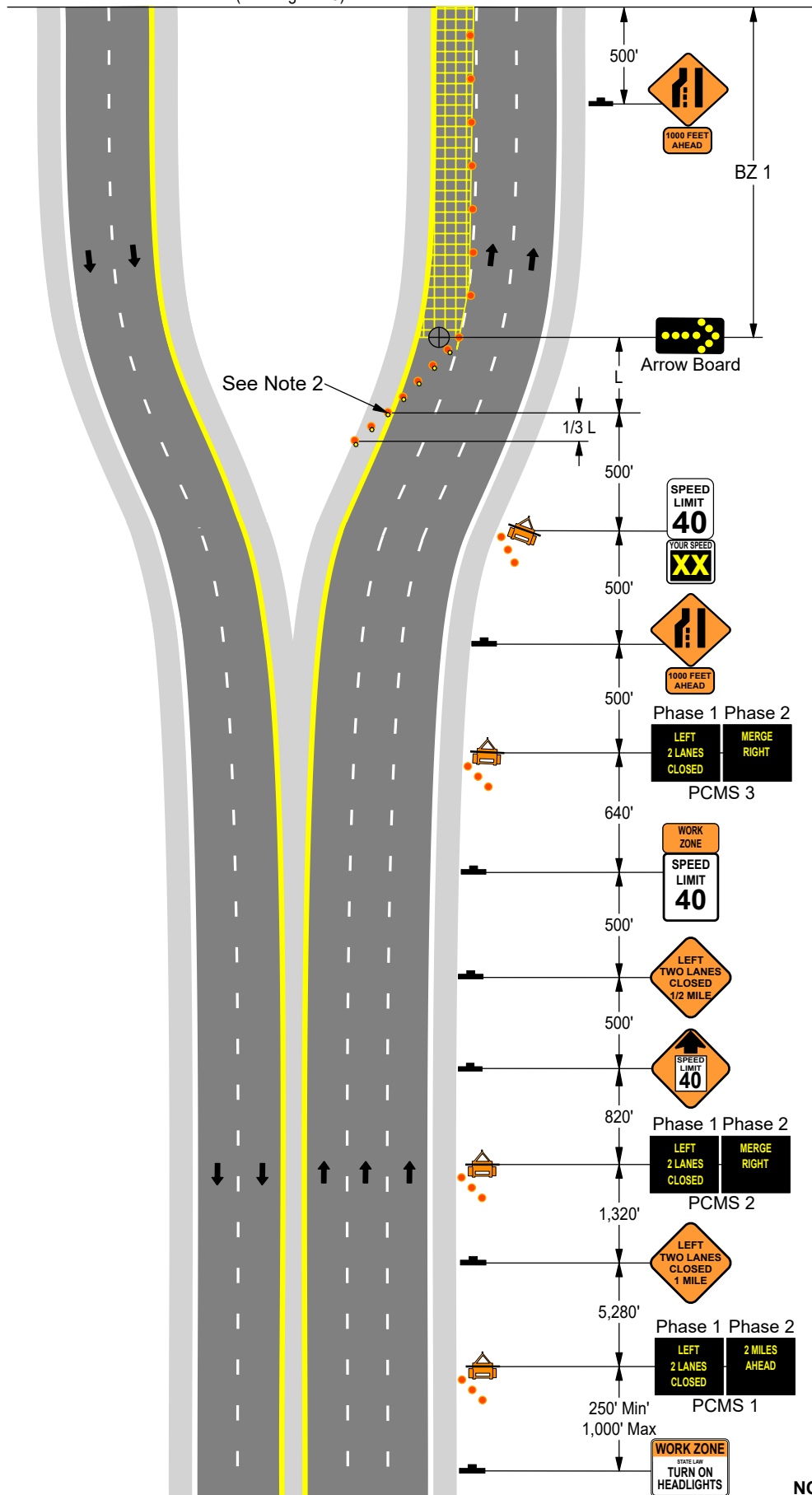

NOTES:
See PTS 930-10 - Notes for applicable notes to this drawing.

See Appendix A for sign descriptions and sizes.

PTS 930-10 Allegheny Tunnel Crossover Pattern (Drawing 2 of 3)

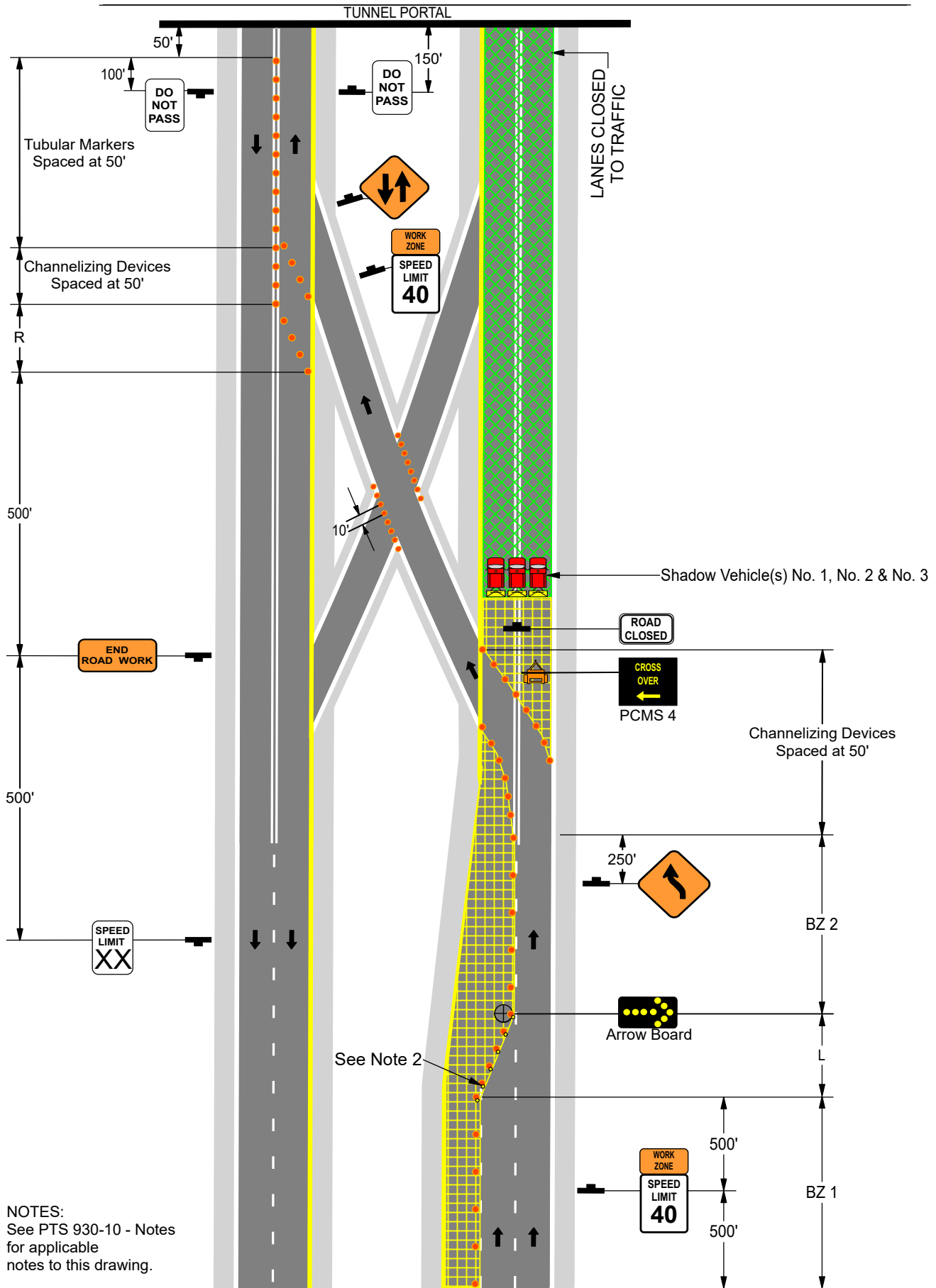

NOTES:
See PTS 930-10 - Notes for applicable notes to this drawing.

See Appendix A for sign descriptions and sizes.

SEE PTS 930-10 (Drawing 1 of 3)

PTS 930-10 Allegheny Tunnel Crossover Pattern (Drawing 3 of 3)

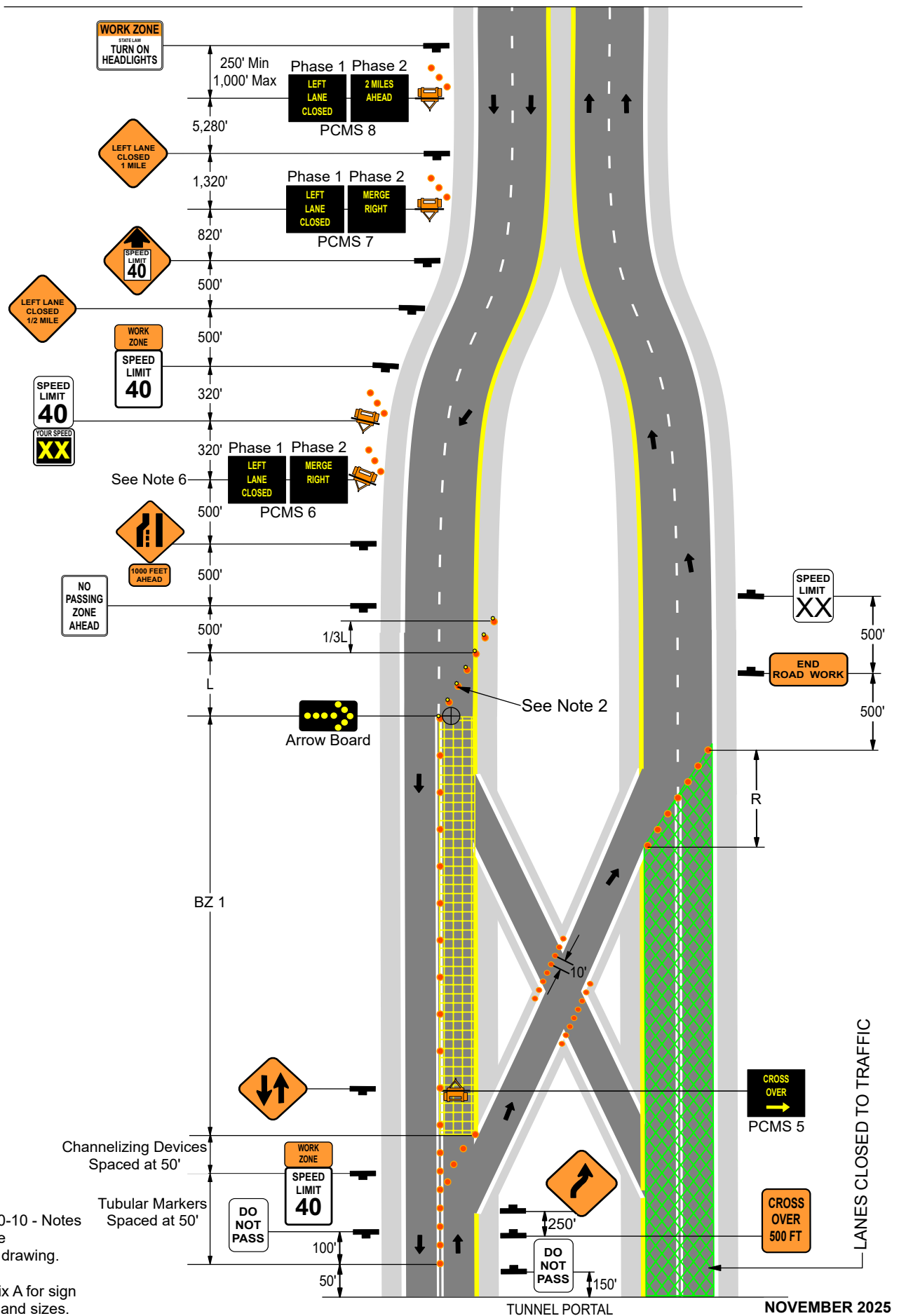

NOTES:
See PTS 930-10 - Notes for applicable notes to this drawing.

See Appendix A for sign descriptions and sizes.

PTS 930-11 - Notes Tuscarora Tunnel Crossover Pattern

1. Use existing "DO NOT CROSS CENTER LINE" sign and existing traffic control signal at portal.
2. Use channelizing devices with PennDOT approved sequential warning lights in the taper areas for patterns used during hours of darkness.
3. Utilize existing CMS and place one (1) PCMS in each direction 1/2 mile to 1 mile in advance of the lane closure when utilizing the Tunnel Crossover Patter with the following message:

Phase 1:	Phase 2:
TRUCKS	NARROW
USE	LANE IN
CAUTION	TUNNEL

4. Tunnel crossover pattern will not be permitted when all lanes are required to be available in accordance with the allowable working hours or the specified holiday restrictions.

Signs

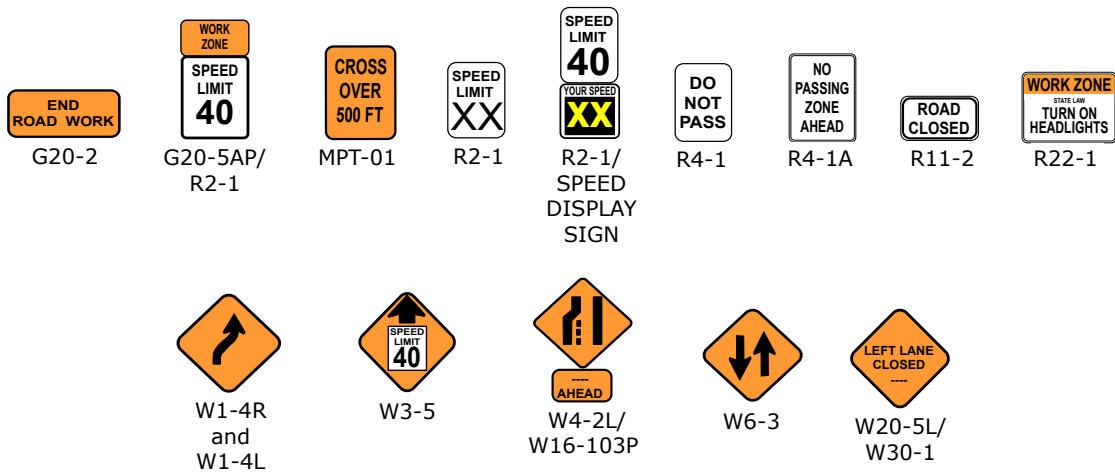

NOTE: See Appendix A for sign descriptions and dimensions.

Distance and Spacing Quick Reference Chart

SPEED	BZ	R	Maximum Channelizing Device Spacing (Feet)	
			BZ	R
55	1,320 (Min)	100	50	20

R = Runout
BZ = Buffer Zone

PTS 930-11 Tuscarora Tunnel Crossover Pattern (Drawing 1 of 2)

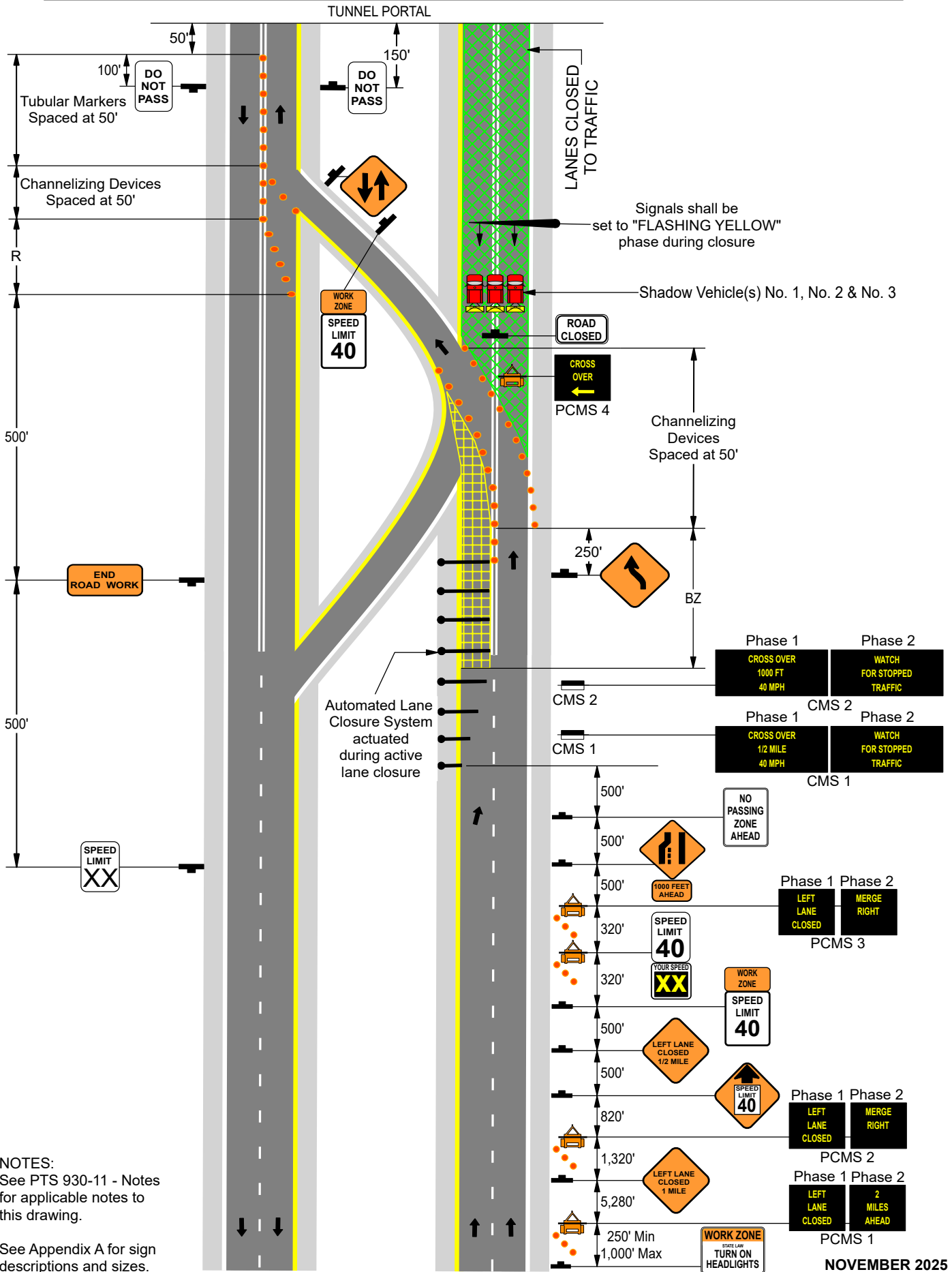

NOTES:
See PTS 930-11 - Notes for applicable notes to this drawing.

See Appendix A for sign descriptions and sizes.

PTS 930-11 Tuscarora Tunnel Crossover Pattern (Drawing 2 of 2)

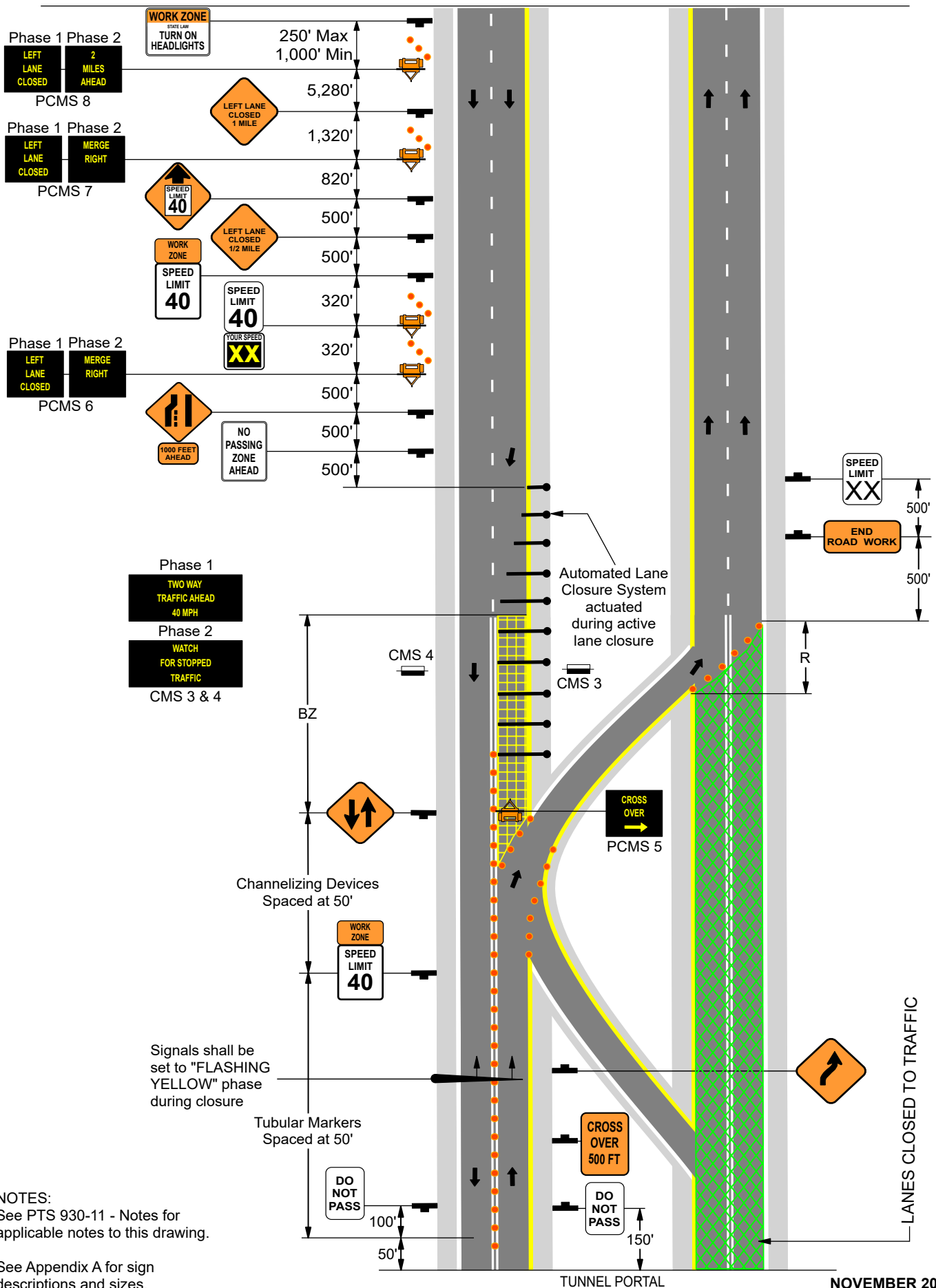

NOTES:
See PTS 930-11 - Notes for applicable notes to this drawing.

See Appendix A for sign descriptions and sizes.

PTS 930-12 - Notes Blue Mountain / Kittatinny Tunnel Crossover Pattern

1. Use existing "DO NOT CROSS CENTER LINE" sign and existing traffic control signal at portal.
2. Use channelizing devices with PennDOT approved sequential warning lights in the taper areas for patterns used during hours of darkness.
3. Tunnel crossover pattern will not be permitted when all lanes are required to be available in accordance with the allowable working hours or the specified holiday restrictions.
4. Utilize existing CMS and place one (1) PCMS in each direction 1/2 mile to 1 mile in advance of the lane closure when utilizing the Tunnel Crossover Pattern with the following message:

Phase 1:	Phase 2:
TRUCKS	NARROW
USE	LANE IN
CAUTION	TUNNEL

Signs

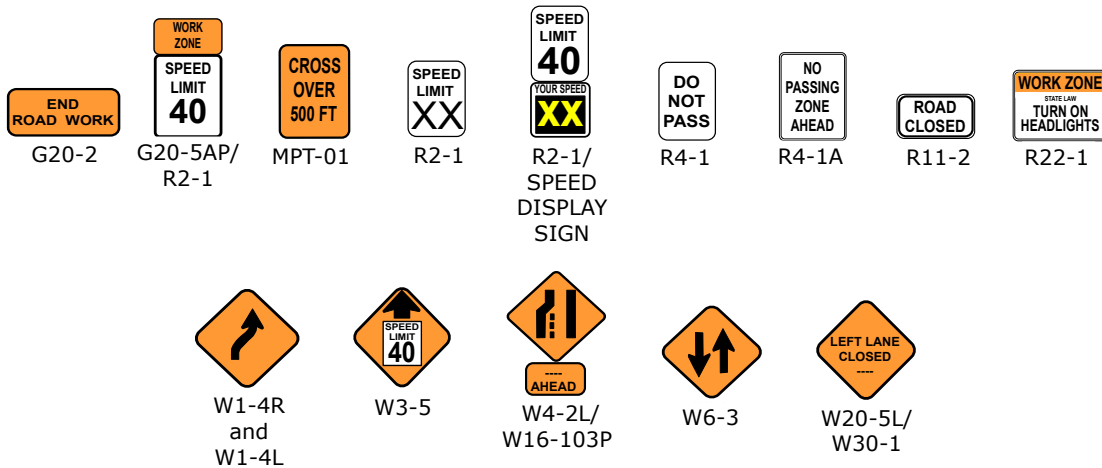

NOTE: See Appendix A for sign descriptions and dimensions.

Distance and Spacing Quick Reference Chart

SPEED	BZ	R	Maximum Channelizing Device Spacing (Feet)	
			BZ	R
MPH	Feet	Feet	BZ	R
55	1,320 (Min)	100	50	20

R = Runout
BZ = Buffer Zone

PTS 930-12
Blue Mountain / Kittatinny Tunnel Crossover Pattern

**TRAFFIC CONTROL BETWEEN
BLUE MOUNTAIN AND KITTATINNY TUNNELS**

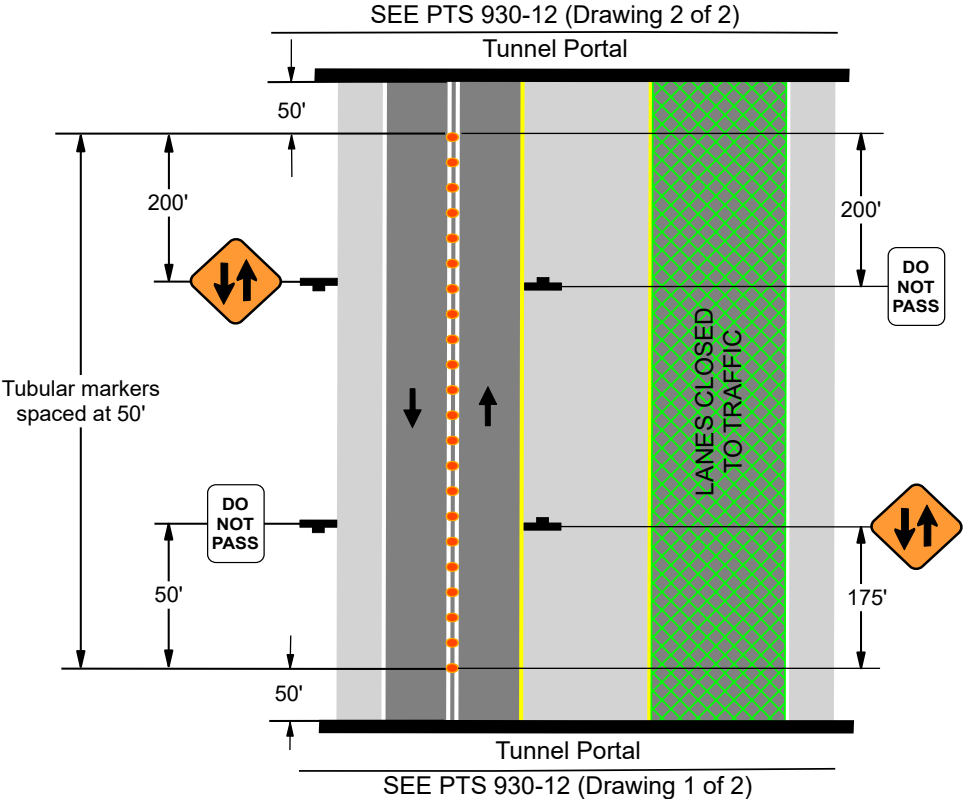

PTS 930-12 Blue Mountain / Kittatinny Tunnel Crossover Pattern (Drawing 1 of 2)

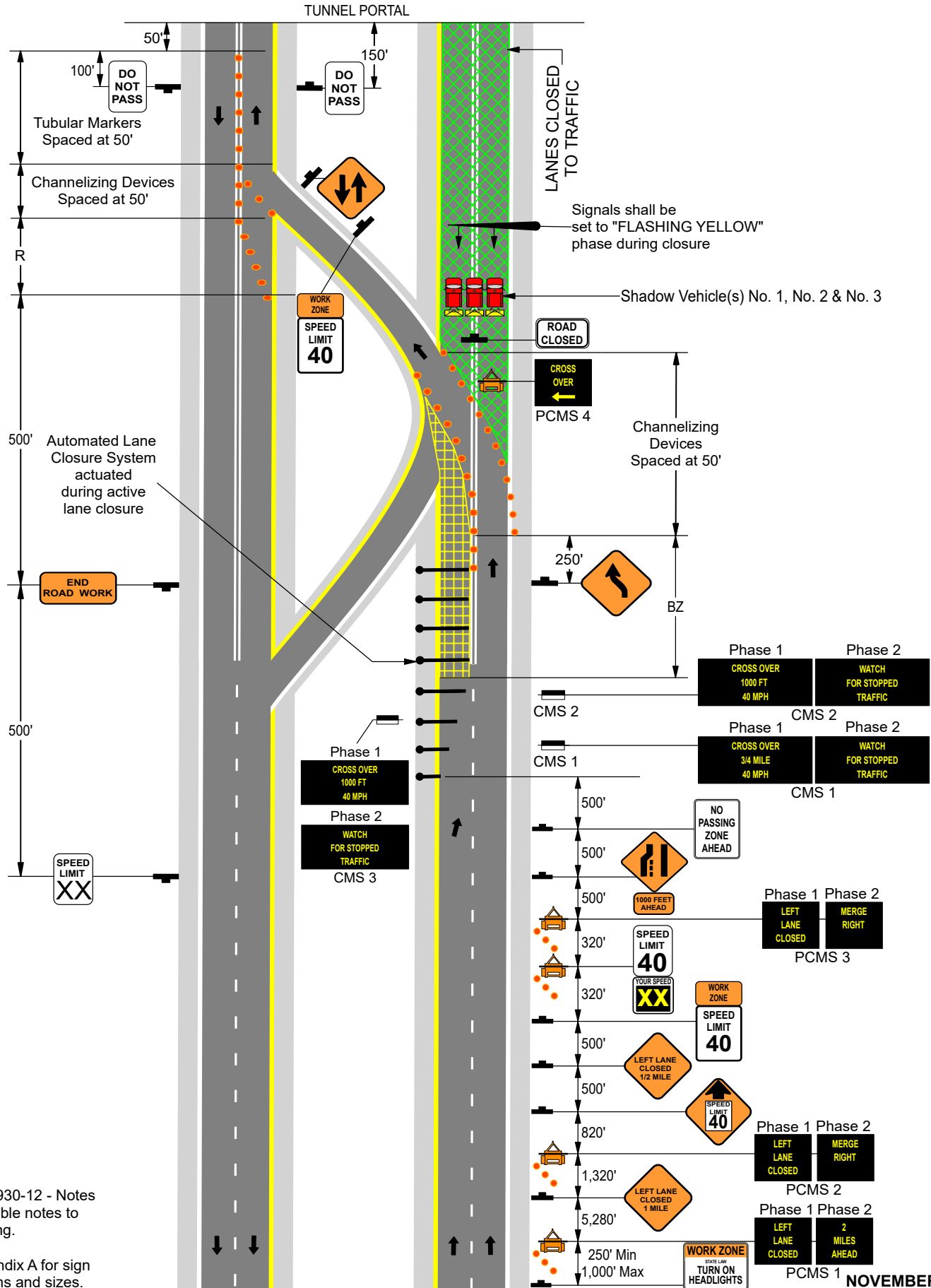

NOTES:
See PTS 930-12 - Notes
for applicable notes to
this drawing.

See Appendix A for sign
descriptions and sizes.

Blue Mountain / Kittatinny Tunnel Crossover Pattern (Drawing 2 of 2)

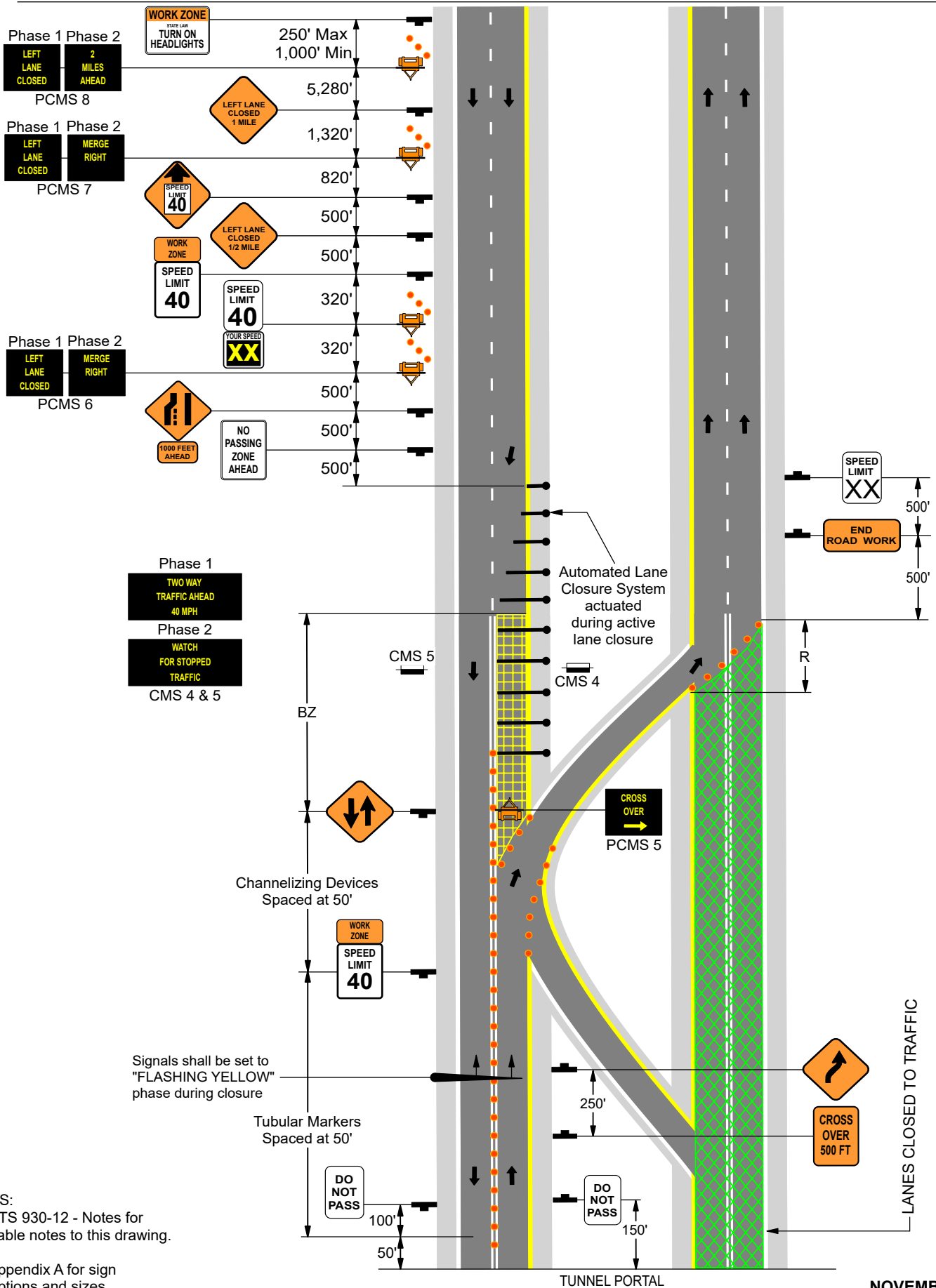

NOTES:
See PTS 930-12 - Notes for applicable notes to this drawing.

See Appendix A for sign descriptions and sizes.

PTS 930-13 - Notes Lehigh Tunnel Crossover Pattern

1. Use existing "DO NOT CROSS CENTER LINE" sign and existing traffic control signal at portal.
2. Use channelizing devices with PennDOT approved sequential warning lights in the taper areas for patterns used during hours of darkness.
3. Tunnel crossover pattern will not be permitted when all lanes are required to be available in accordance with the allowable working hours or the specified holiday restrictions.
4. Utilize existing CMS and place one (1) PCMS in each direction 1/2 mile to 1 mile in advance of the lane closure when utilizing the Tunnel Crossover Pattern with the following message:

Phase 1:	Phase 2:
TRUCKS	NARROW
USE	LANE IN
CAUTION	TUNNEL

5. Compute the minimum desirable merging taper length for reduction in lanes using the following formula:

$$L = S_N \times W$$

Where L = Minimum desirable merging taper length in feet
W = Width of offset in feet
 S_N = Normal speed limit in miles per hour

Signs

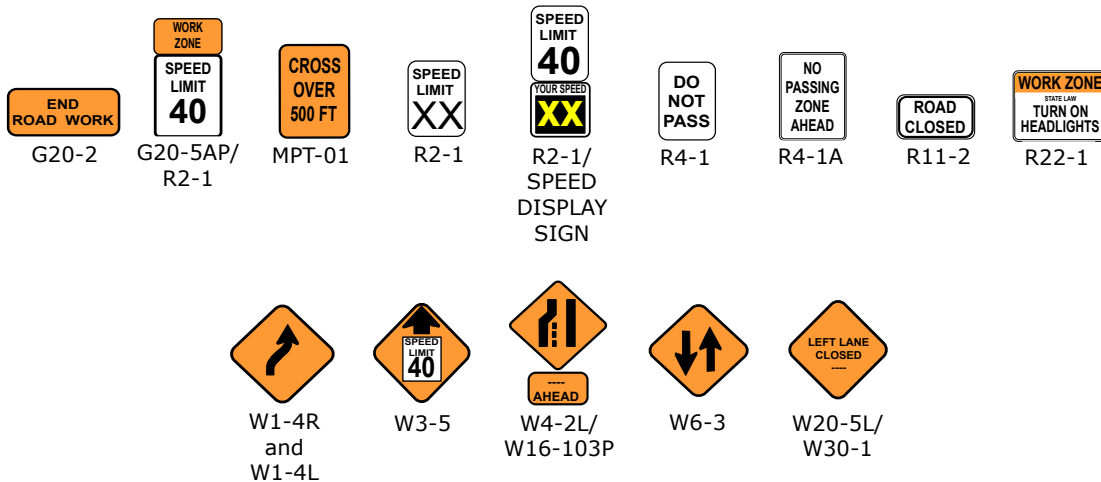

NOTE: See Appendix A for sign descriptions and dimensions.

Distance and Spacing Quick Reference Chart

SPEED	L	1/3 L	BZ	R	Maximum Channelizing Device Spacing (Feet)			
					L	1/3 L	BZ	R
MPH	Feet	Feet	Feet	Feet	L	1/3 L	BZ	R
55	660	220	1,320 (Min)	100	50	50	100	20

L = Merging Taper
1/3L = Shoulder Taper
BZ = Buffer Zone
R = Runout

PTS 930-13 Lehigh Tunnel Crossover Pattern (Drawing 1 of 2)

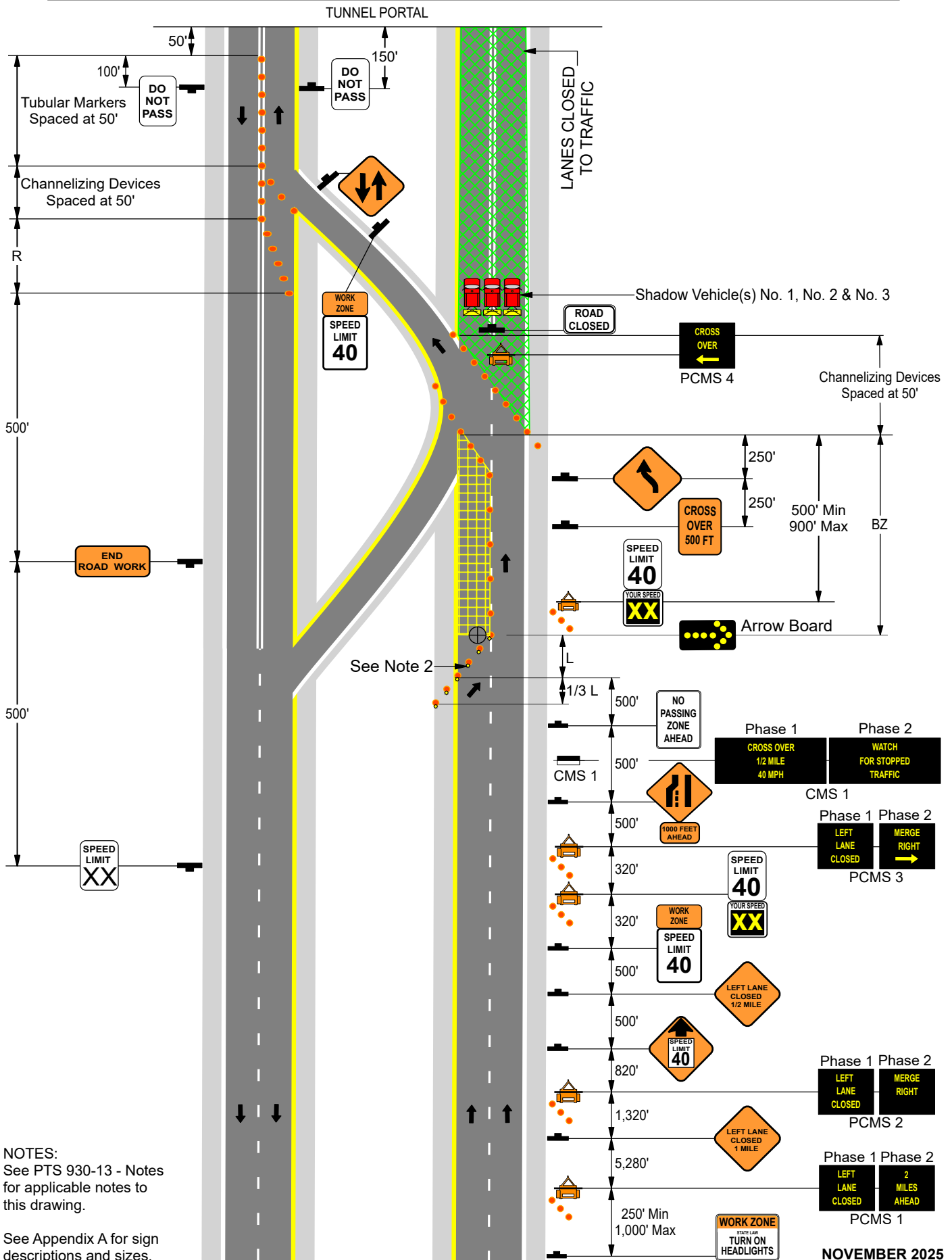

NOTES:
See PTS 930-13 - Notes
for applicable notes to
this drawing.

See Appendix A for sign
descriptions and sizes.

PTS 930-13 Lehigh Tunnel Crossover Pattern (Drawing 2 of 2)

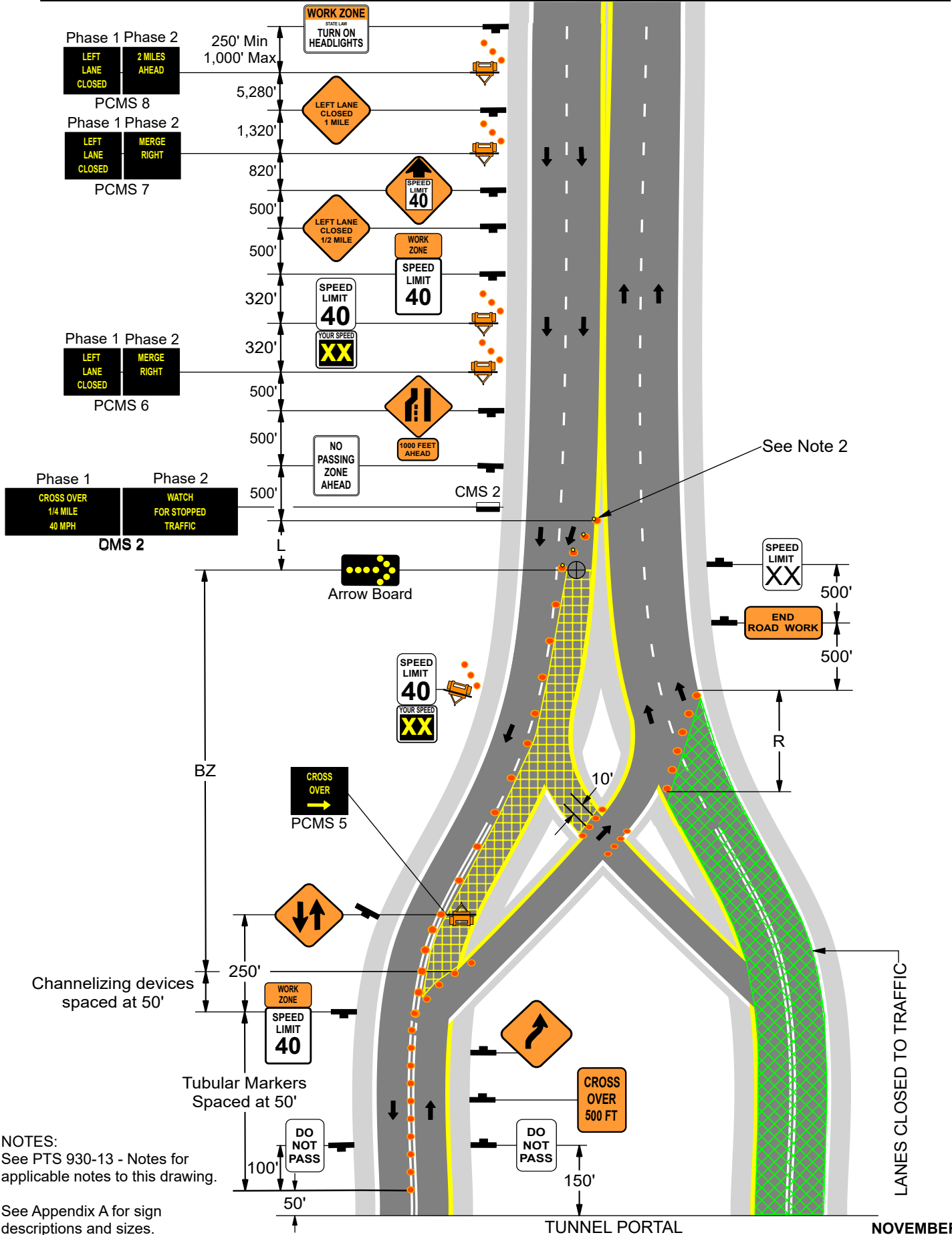

NOTES:
See PTS 930-13 - Notes for applicable notes to this drawing.

See Appendix A for sign descriptions and sizes.

PTS 930-14 - Notes Stationary Shoulder Closure with Temporary Barrier

1. For left shoulder work zone, use the same sign spacing, location, and pattern but with the signs and PCMS indicating a left shoulder closure.
2. Taper temporary barrier 30:1 to the outside of the paved shoulder, or median.
3. Provide proper end treatment for barrier, by tapering barrier and burying, tapering barrier and connect to guide rail per PTS-135 or barrier, or tapering barrier and provide temporary impact attenuator with minimum 6 feet offset per PTS 009.
4. For multiple stationary shoulder closures with temporary barrier located within 1 mile of each other, install advanced signing prior to the first stationary shoulder closure only, with distance displayed on the MPT-31 sign as the length from the beginning of the first stationary shoulder closure to the end of the last stationary shoulder closure. The G20-2 sign is to be installed after the last stationary shoulder closure.
5. MPT-31 sign shall only be used if the length of the physical work zone is greater than 1 mile.
6. R2-1, G20-5AP/R2-1, W3-5, and Speed Display Signs shall only be used if the length of the physical work zone is greater than 1 mile. Provide G20-5AP/R2-1 at 1 mile intervals throughout the shoulder closure.
7. Install W3-5 sign only in areas where normal speed limit is 70 MPH.
8. Completely cover signs used with this pattern when the right lane is closed to traffic per PTS 930-3 or PTS 930-4.
9. Provide emergency pull-offs at a spacing of approximately 1 mile through the physical work zone when a minimum of 12 feet of right shoulder is not available.
10. When construction vehicles are accessing the work area from the travel lanes for a minimum of 15 minutes, provide the advanced signing for the active construction access point per PTS 930-20 or PTS 930-21, as applicable. When construction access is not used for 60 minutes, cover signs, turn off Type B light and turn off PCMS.
11. Delineate attenuators placed on the paved shoulder with a minimum of 3 PennDOT approved channelizing devices per PTS 009.
12. Provide 6 inch temporary waterborne paint lines the full length of temporary barrier.
13. For left and right shoulder closures with temporary barrier occurring concurrently, install MPT-39 in lieu of W21-5BR or W21-5BL.

Signs

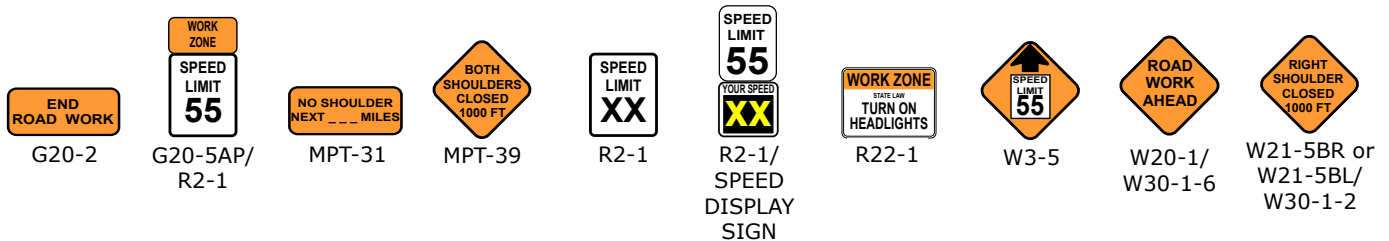

NOTE: See Appendix A for sign descriptions and dimensions.

Distance and Spacing Quick Reference Chart

SPEED	Shoulder	WZ	R
MPH	Rate	Mile(s)	Feet
55	30:1	4 (Max)	100
70	30:1	4 (Max)	100

Shoulder = Shoulder Taper
WZ = Work Zone
R = Runout

PTS 930-14A Stationary Shoulder Closure with Temporary Barrier

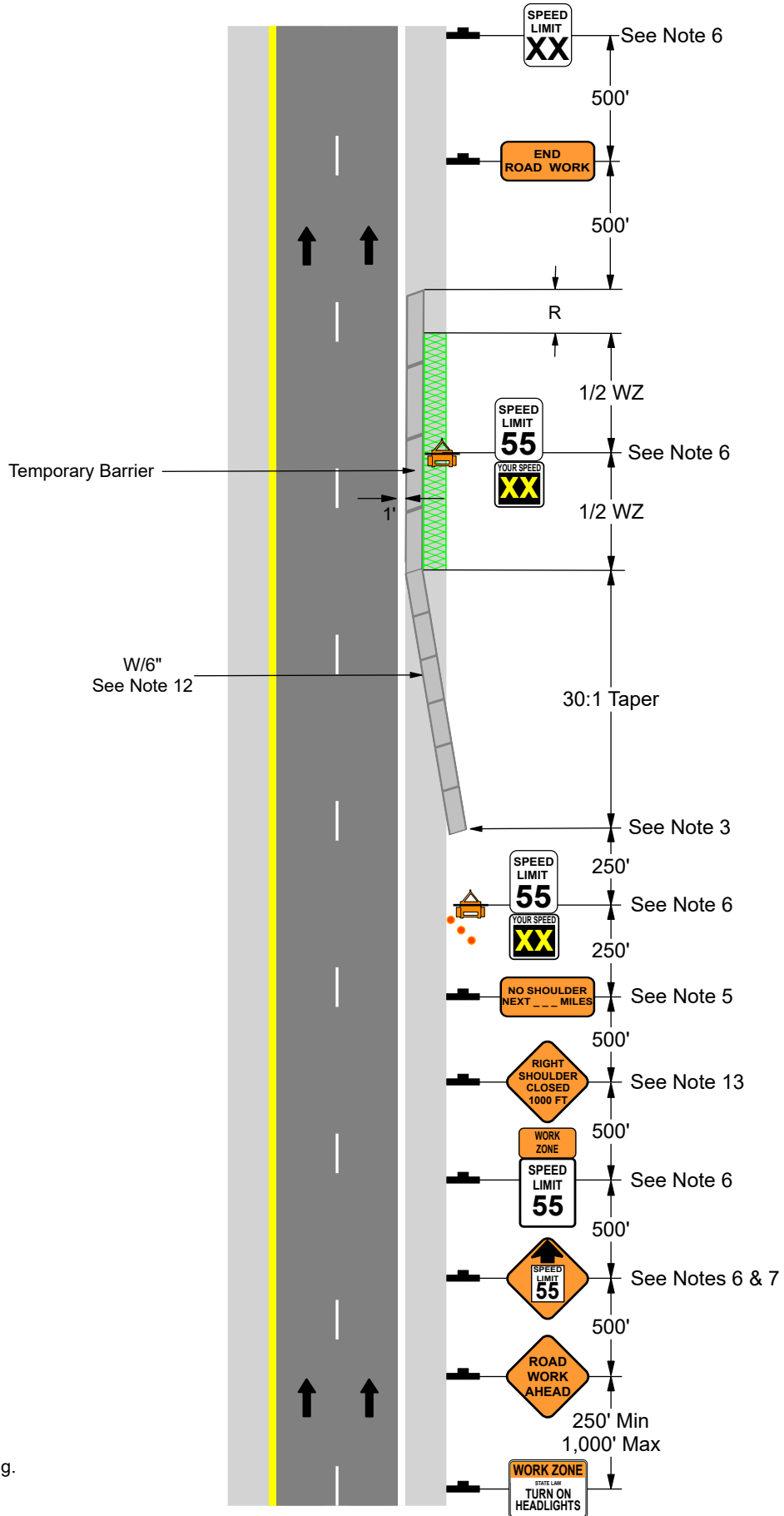

NOTE:
See PTS 930-14 - Notes for applicable notes to this drawing.

See Appendix A for sign descriptions and sizes.

PTS 930-14B Multiple Stationary Shoulder Closures with Temporary Barrier

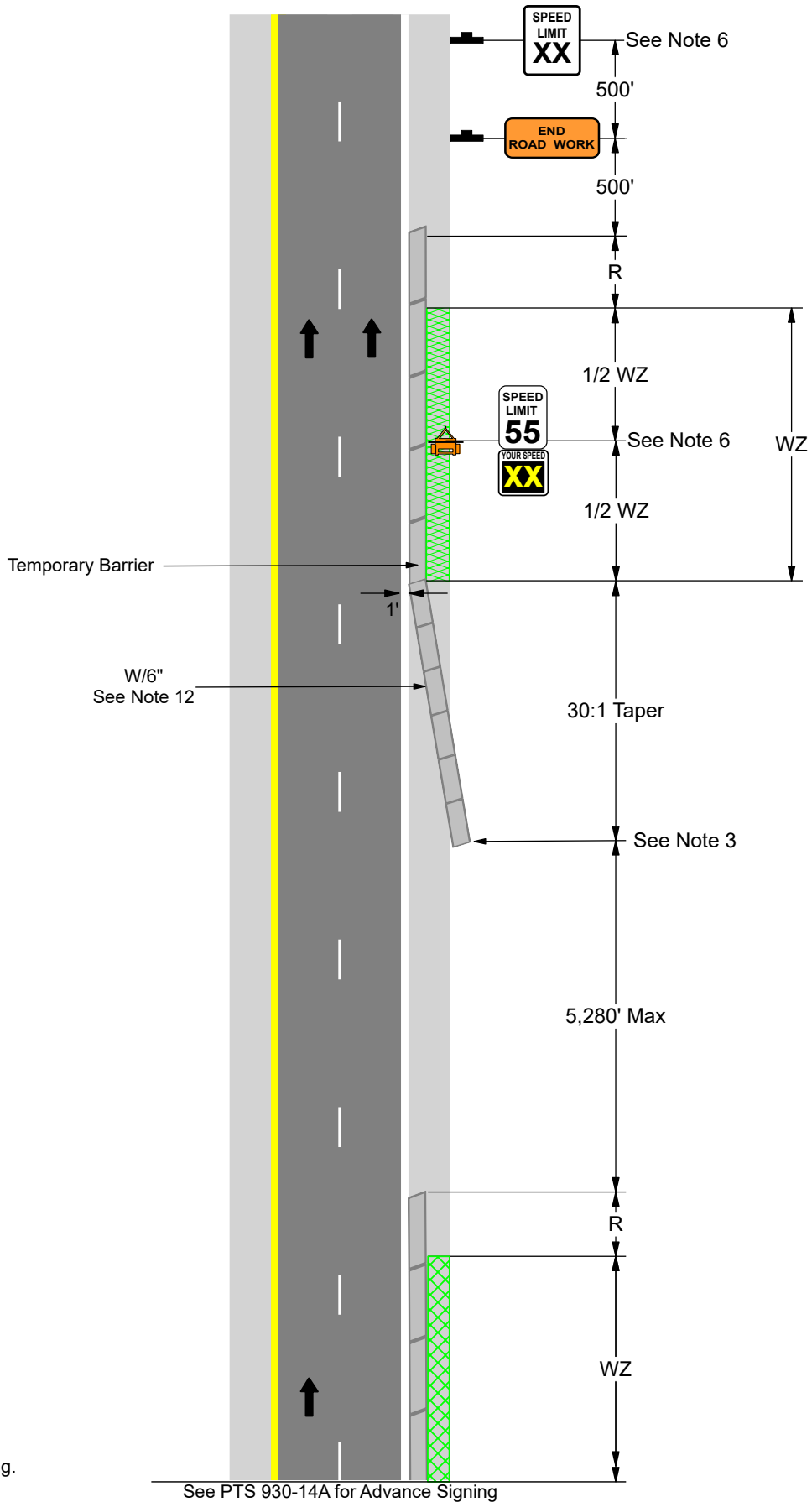

NOTE:
See PTS 930-14 - Notes for applicable notes to this drawing.

See Appendix A for sign descriptions and sizes.

See PTS 930-14A for Advance Signing

PTS 930-15 - Notes

Single Lane Closure with Temporary Barrier

1. This detail may only be used if authorized by Commission's Traffic Engineering and Operations Department.
2. For left lane work zone, use the same sign spacing, location, and pattern but with the signs and PCMS indicating a left lane closure. Do not include arrow on Phase 2 of PCMS 3 with left lane closure.
3. Provide emergency pull-offs at a spacing of approximately 1 mile through the lane closure.
4. Remove conflicting broken white line between the center lane and right lane for a right lane closure or the left lane and center lane for a left lane closure.
5. Taper temporary barrier 30:1 to outside of the paved shoulder, or median.
6. Provide proper end treatment for barrier by tapering barrier and burying, tapering barrier and connecting to guide rail per PTS-135 or barrier, or tapering barrier and providing temporary impact attenuator with minimum 6 feet offset per PTS 009.
7. From this point, provide G20-5AP/R2-1 signs to the right of traffic at 1 mile intervals through the long-term lane closure pattern.
8. Delineate attenuators placed on the paved shoulder with a minimum of 3 PennDOT approved channelizing devices per PTS 009.
9. Additional arrow boards may be used in the closed lane as long as they operate in Caution Mode.
10. Speed Display Sign shall only be used if the length of the physical work zone is greater than or equal to 500 feet.
11. Provide 6 inch temporary waterborne paint lines the full length of temporary barrier.

Signs

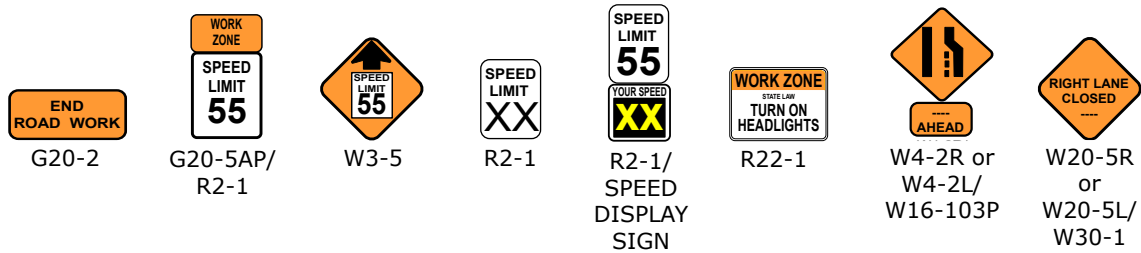

NOTE: See Appendix A for sign descriptions and dimensions.

Distance and Spacing Quick Reference Chart

SPEED	Shoulder	Median	L	WZ	R	Maximum Channelizing Device Spacing (Feet)			
						Shoulder	L & 1/3L	WZ	R
MPH	Rate	Rate	Rate	Mile(s)	Feet	N/A	50	N/A	20
55	30:1	55:1	55:1	4 (Max)	100	N/A	50	N/A	20
70	30:1	55:1	70:1	4 (Max)	100	N/A	50	N/A	20

L = Merging Taper
WZ = Work Zone
R = Runout

PTS 930-15 Single Lane Closure with Temporary Barrier

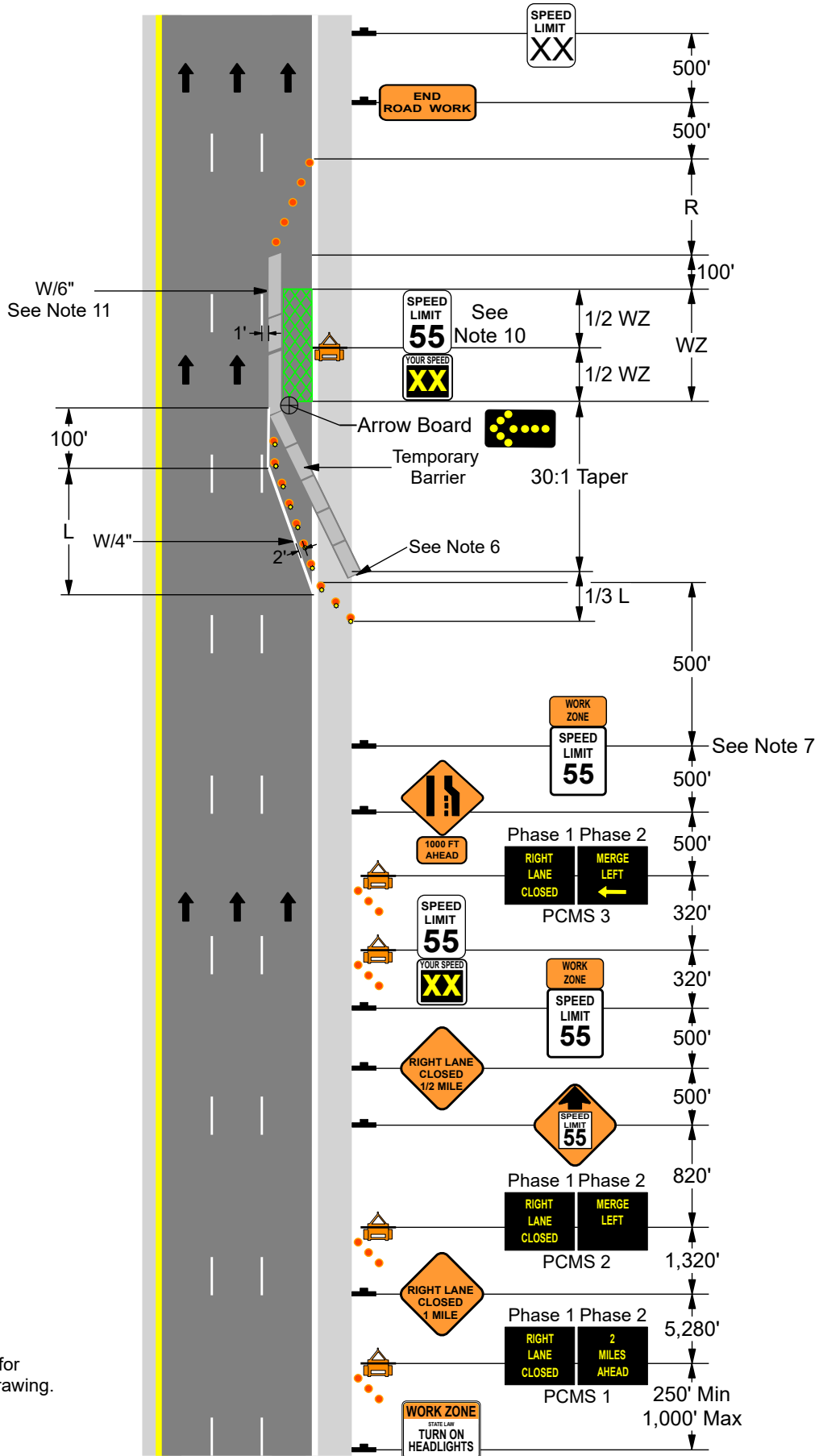

NOTES:
See PTS 930-15 - Notes for applicable notes to this drawing.

See Appendix A for sign descriptions and sizes.

PTS 930-16 - Notes Lanes Shift - 2 Lanes Shift

1. W24-1AL and W24-1AR signs may be used in lieu of the W1-4BL and W1-4BR signs when the tangent distance for the shifted traffic makes it difficult to install a second set of two lane reverse curve signs (W1-4B series).
2. Provide emergency pull-offs at a spacing of approximately 1 mile through physical work zone when full shoulder is not available.
3. Taper temporary barrier 30:1 to outside edge of paved shoulder or median.
4. Provide proper end treatment for barrier, by tapering barrier and burying, tapering barrier and connect to guide rail per PTS-135 or barrier, or tapering barrier to provide temporary impact attenuator with minimum 6 feet offset per PTS 009.
5. From this point, provide G20-5AP/R2-1 signs to the right of traffic at 1 mile intervals through the lane(s) shift pattern.
6. MPT-31 sign shall only be used if the length of the physical work zone is greater than 1 mile.
7. Compute the minimum desirable shifting taper length for reduction in lanes using the following formula:

$$L = S_{WZ} \times W$$

Where L = Minimum desirable shifting taper length in feet
W = Width of offset in feet
 S_{WZ} = Normal speed limit in miles per hour

8. Delineate attenuators placed on the paved shoulder with a minimum of 3 PennDOT approved channelizing devices per PTS 009.
9. Speed Display Sign shall only be used if the length of the physical work zone is greater than or equal to 500 feet.
10. Provide 6 inch temporary waterborne paint lines the full length of temporary barrier.
11. Install W3-5 sign only in the areas where the normal speed limit is 70 MPH.
12. When field conditions allow, provide a 1 foot offset to the temporary barrier during all stages.
13. Buffer zone shall only be used for projects that have a physical work zone in the median.
14. For multiple lane shifts located within 1 mile of each other, install advanced signing prior to the first lane shift only, with the distance displayed on the MPT-31 sign as the length from the beginning of the first lane shift to the end of the last lane shift. W1-4BL/W16-103P or W1-4BR/W16-103P signs shall be installed at 500 feet and 1,000 feet prior to each lane shift after the first lane shift.

Signs

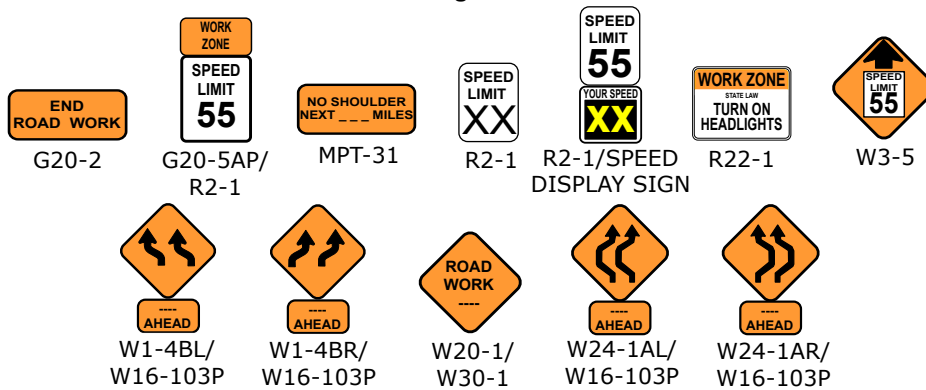

NOTE: See Appendix A for sign descriptions and dimensions.

Distance and Spacing Quick Reference Chart

SPEED	Shoulder	Median	L	BZ	WZ	R	Maximum Channelizing Device Spacing (Feet)
MPH	Rate	Rate	Rate	Feet	Mile(s)	Feet	L
55	30:1	30:1	55:1	100 (Min)	4 (Max)	100	50
70	30:1	30:1	70:1	100 (Min)	4 (Max)	100	50

L = Merging Taper
BZ = Buffer Zone
WZ = Work Zone
R = Runout

PTS 930-16B Lanes Shift Detail - 2 Lanes Shift - Right

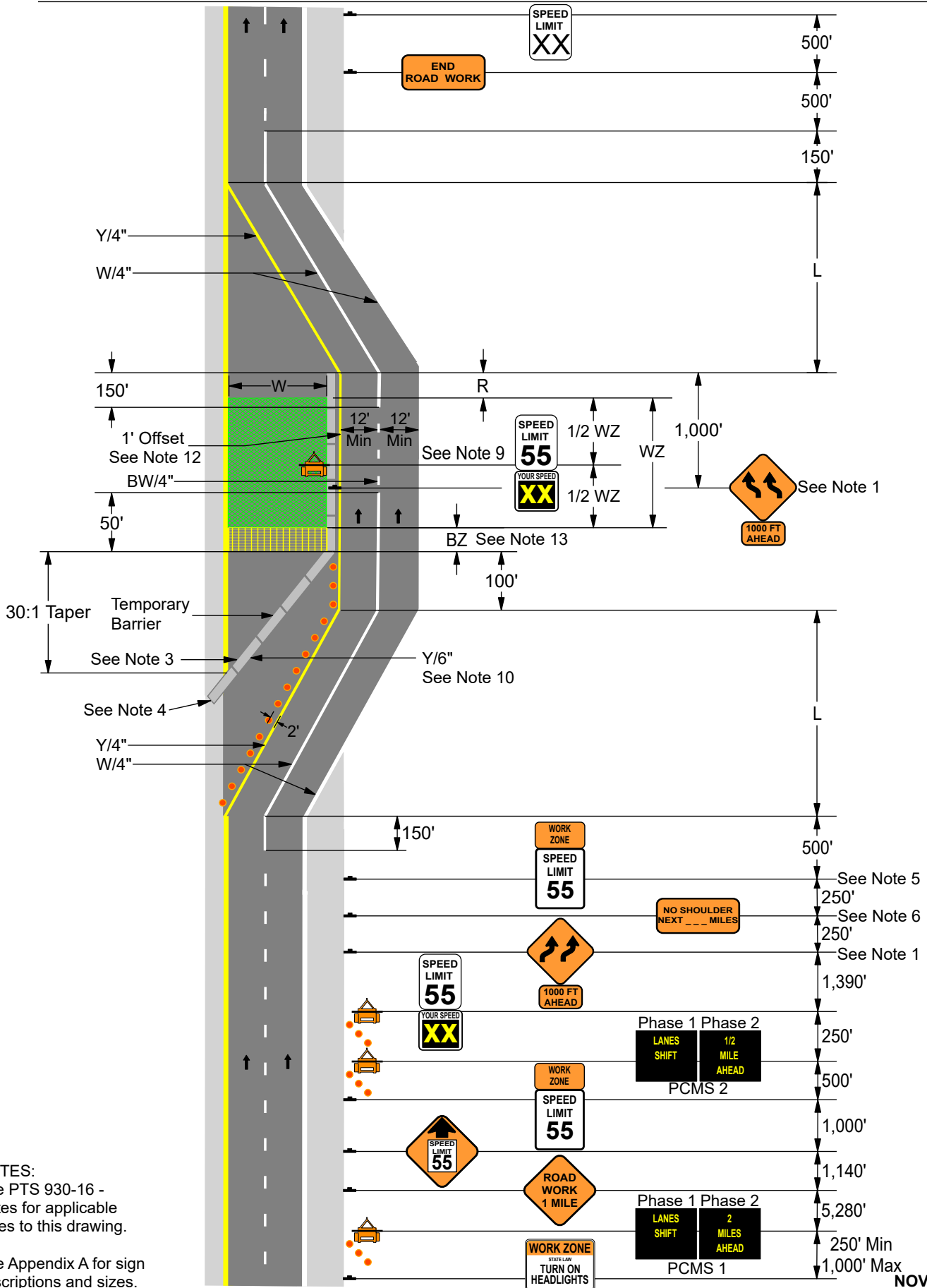

NOTES:
See PTS 930-16 -
Notes for applicable
notes to this drawing.

See Appendix A for sign
descriptions and sizes.

PTS 930-17 - Notes Lanes Shift - 3 Lanes Shift

1. W24-1BL and W24-1BR signs may be used in lieu of the W1-4CL and W1-4CR signs when the tangent distance for the shifted traffic makes it difficult to install a second set of three lane reverse curve signs (W1-4C series).
2. Provide emergency pull-offs at a spacing of approximately 1 mile through physical work zone when full shoulder is not available.
3. Taper temporary barrier 30:1 to outside edge of paved shoulder, or median.
4. Provide proper end treatment for barrier, by tapering barrier and burying, tapering barrier and connect to guide rail per PTS-135 or barrier, or tapering barrier to provide temporary impact attenuator with minimum 6 feet offset per PTS 009.
5. From this point, provide G20-5AP/R2-1 signs to the right of traffic at 1 mile intervals through the lane(s) shift pattern.
6. MPT-31 sign shall only be used if the length of the physical work zone is greater than 1 mile.
7. Compute the minimum desirable shifting taper length for reduction in lanes using the following formula:

$$L = S_{WZ} \times W$$

Where L = Minimum desirable shifting taper length in feet
W = Width of offset in feet
 S_{WZ} = Normal speed limit in miles per hour

8. Delineate attenuators placed on the paved shoulder with a minimum of 3 PennDOT approved channelizing devices per PTS 009.
9. Speed Display Sign shall only be used if the length of the physical work zone is greater than or equal to 500 feet.
10. Provide 6 inch temporary waterborne paint lines the full length of temporary barrier.
11. Install W3-5 sign only in the areas where the normal speed limit is 70 MPH.
12. When field conditions allow, provide a 1 foot offset to the temporary barrier during all stages.
13. Buffer zone shall only be used for projects that have a physical work zone in the median.
14. For multiple lane shifts located within 1 mile of each other, install advanced signing prior to the first lane shift only, with the distance displayed on the MPT-31 sign as the length from the beginning of the first lane shift to the end of the last lane shift. W1-4CL/W16-103P or W1-4CR/W16-103P signs shall be installed at 500 feet and 1,000 feet prior to each lane shift after the first lane shift.

Signs

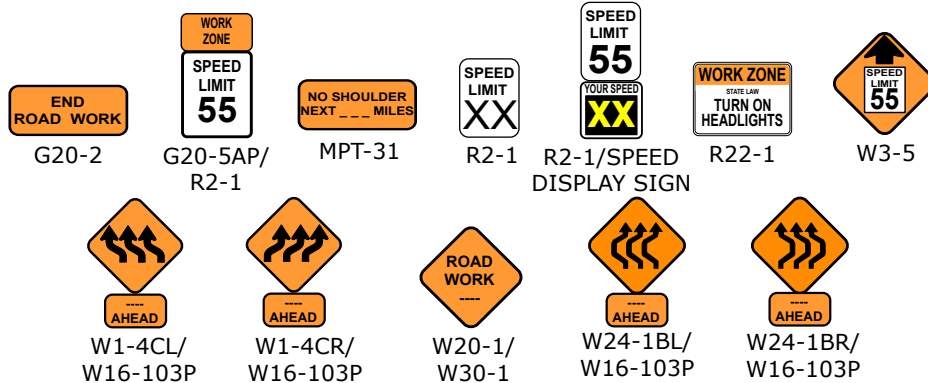

NOTE: See Appendix A for sign descriptions and dimensions.

Distance and Spacing Quick Reference Chart

SPEED	Shoulder	Median	L	BZ	WZ	R	Maximum Channelizing Device Spacing (Feet)
MPH	Rate	Rate	Rate	Feet	Mile(s)	Feet	L
55	30:1	30:1	55:1	100 (Min)	4 (Max)	100	50
70	30:1	30:1	70:1	100 (Min)	4 (Max)	100	50

L = Merging Taper
BZ = Buffer Zone
WZ = Work Zone
R = Runout

PTS 930-17A Lanes Shift Detail - 3 Lanes Shift - Left

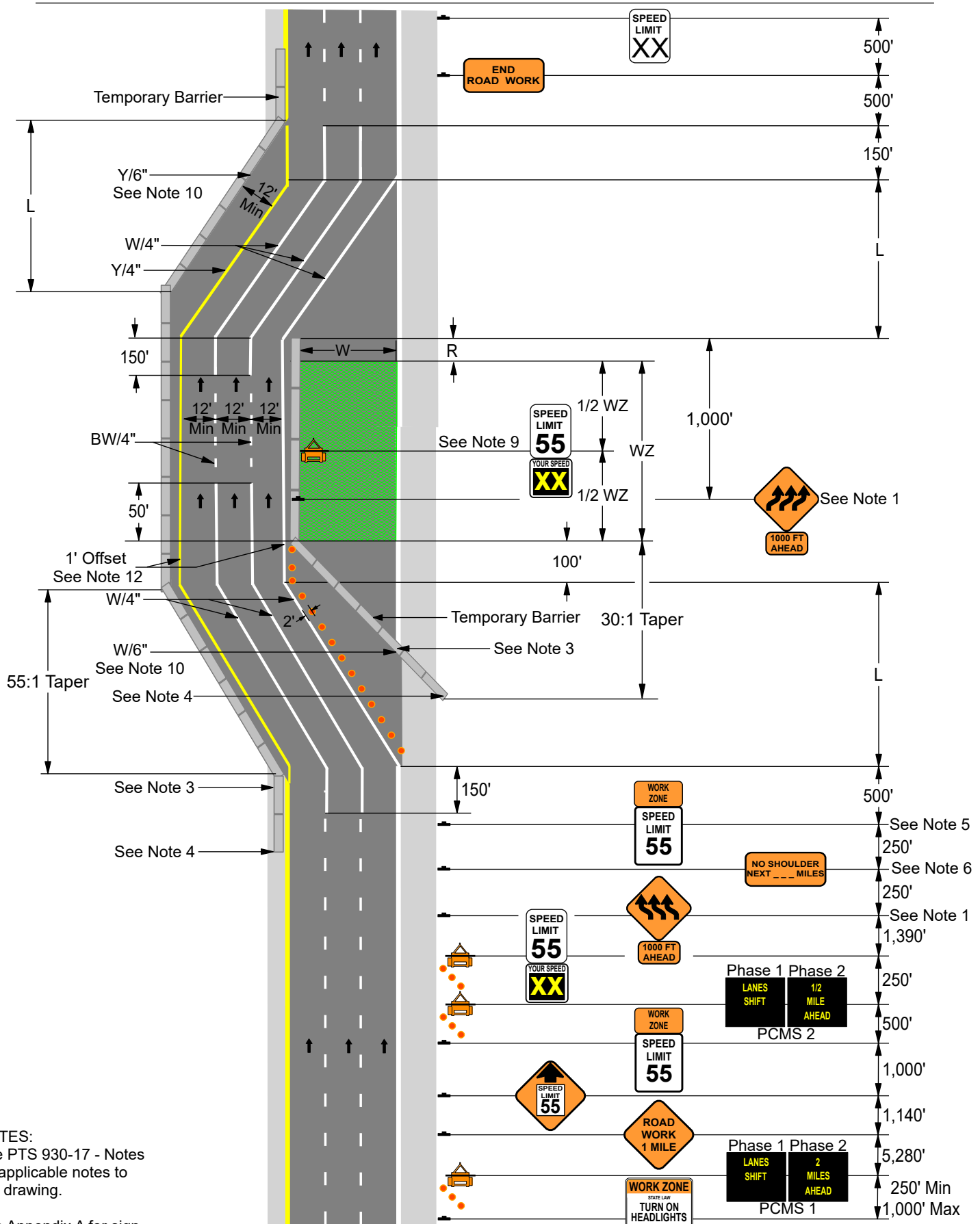

NOTES:
See PTS 930-17 - Notes
for applicable notes to
this drawing.

See Appendix A for sign
descriptions and sizes.

PTS 930-17B Lanes Shift Detail - 3 Lanes Shift - Right

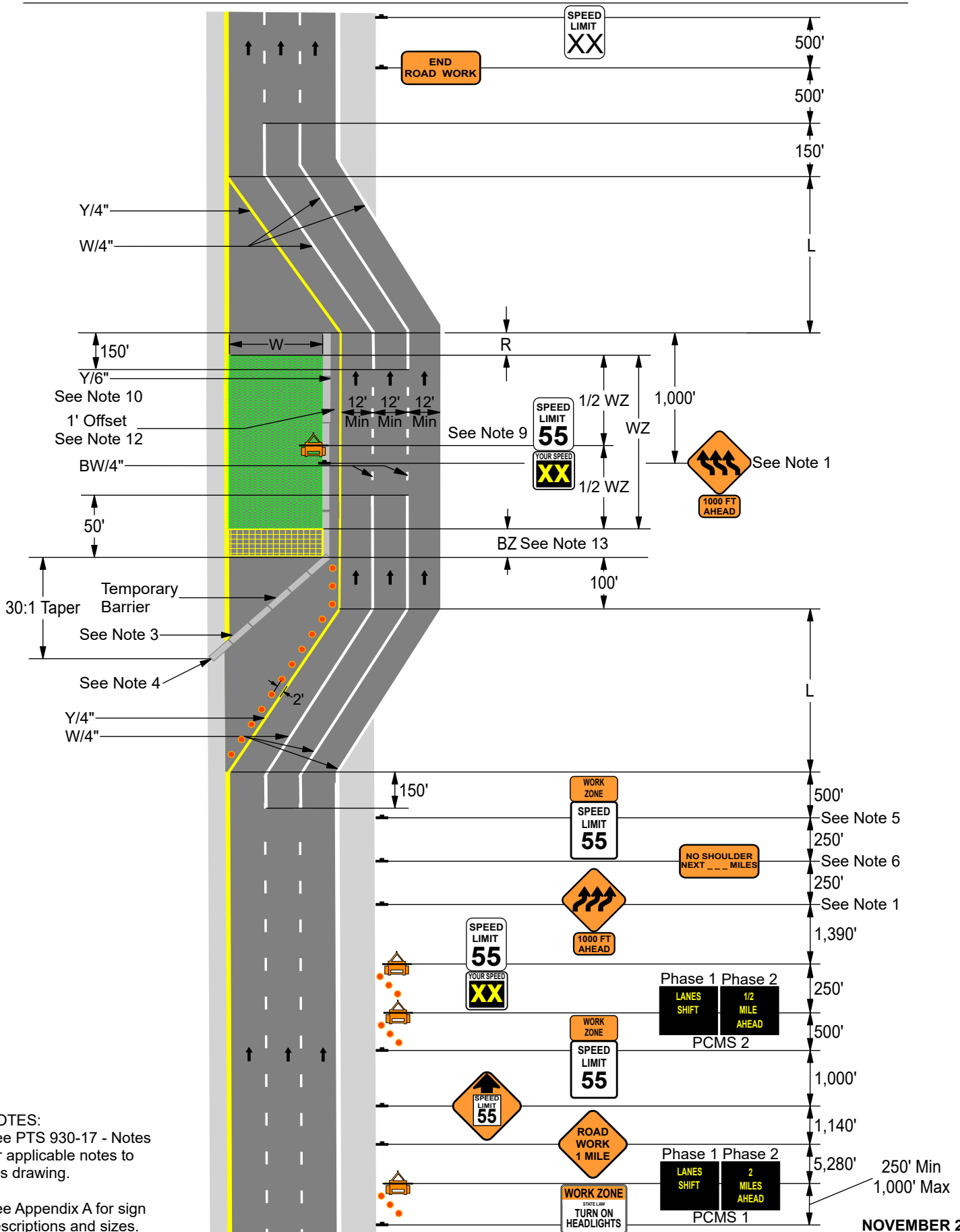

NOTES:
See PTS 930-17 - Notes
for applicable notes to
this drawing.

See Appendix A for sign
descriptions and sizes.

PTS 930-18 - Notes Crossover Traffic Pattern

1. This detail may only be used if authorized by Commission's Traffic Engineering and Operations Department.
2. Provide sufficient Type III barricades to close off the entire road.
3. Provide proper end treatment for barrier, by tapering barrier and burying, tapering barrier and connect to guide rail per PTS-135 or barrier, or tapering barrier and provide temporary impact attenuator with minimum 6 feet offset per PTS 009.
4. Use channelizing devices with PennDOT approved sequential warning lights in the taper areas for pattern used during hours of darkness.
5. From this point, provide G20-5AP / R2-1 signs to the right of traffic at 1 mile intervals through the crossover traffic pattern.
6. MPT-31 sign shall only be used if the length of the physical work zone is greater than 1 mile.
7. Compute the minimum desirable taper length for reduction in lanes using the following formula:

Lane Shift Variables:

$$L = S_N \times W$$

$$L_1 = S_N \times W$$

L_2 = Minimum desirable shifting taper length in feet

W = Width of offset in feet

S_N = Normal speed limit in miles per hour

S_{WZ} = Work Zone speed limit in miles per hour

8. Crossover area shall be lighted.
9. Additional arrow boards may be used in the closed lane(s) as long as they operate in Caution Mode.
10. Speed Display Sign shall only be used if the length of the physical work zone is greater than or equal to 500 feet.
11. Provide 6 inch temporary waterborne paint lines the full length of temporary barrier.
12. If no shoulder is available, provide a minimum lane width of 14 feet.

Signs

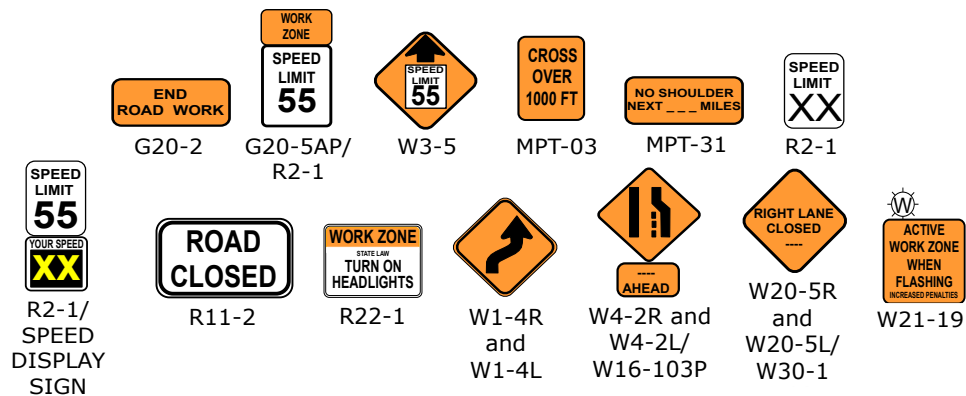

NOTE: See Appendix A for sign descriptions and dimensions.

Distance and Spacing Quick Reference Chart

SPEED	L 1	L 2	1/3 L1	BZ	WZ	R	Maximum Channelizing Device Spacing (Feet)					
							1/3 L1	L 1	L 2	BZ	WZ	R
MPH	Feet	Feet	Feet	Feet	Mile(s)	Feet	1/3 L1	L 1	L 2	BZ	WZ	R
55	660	660	220	1,320 (Min)	4 (Max)	100	50	50	50	100	100	20
70	840	660	280	1,680 (Min)	4 (Max)	100	50	50	50	100	100	20

- L 1 = Merging Taper
- L 2 = Shifting Taper
- 1/3 L = Shoulder Taper
- BZ = Buffer Zone
- WZ = Work Zone
- R = Runout

PTS 930-18 Crossover Traffic Pattern Detail (Drawing 1 of 2)

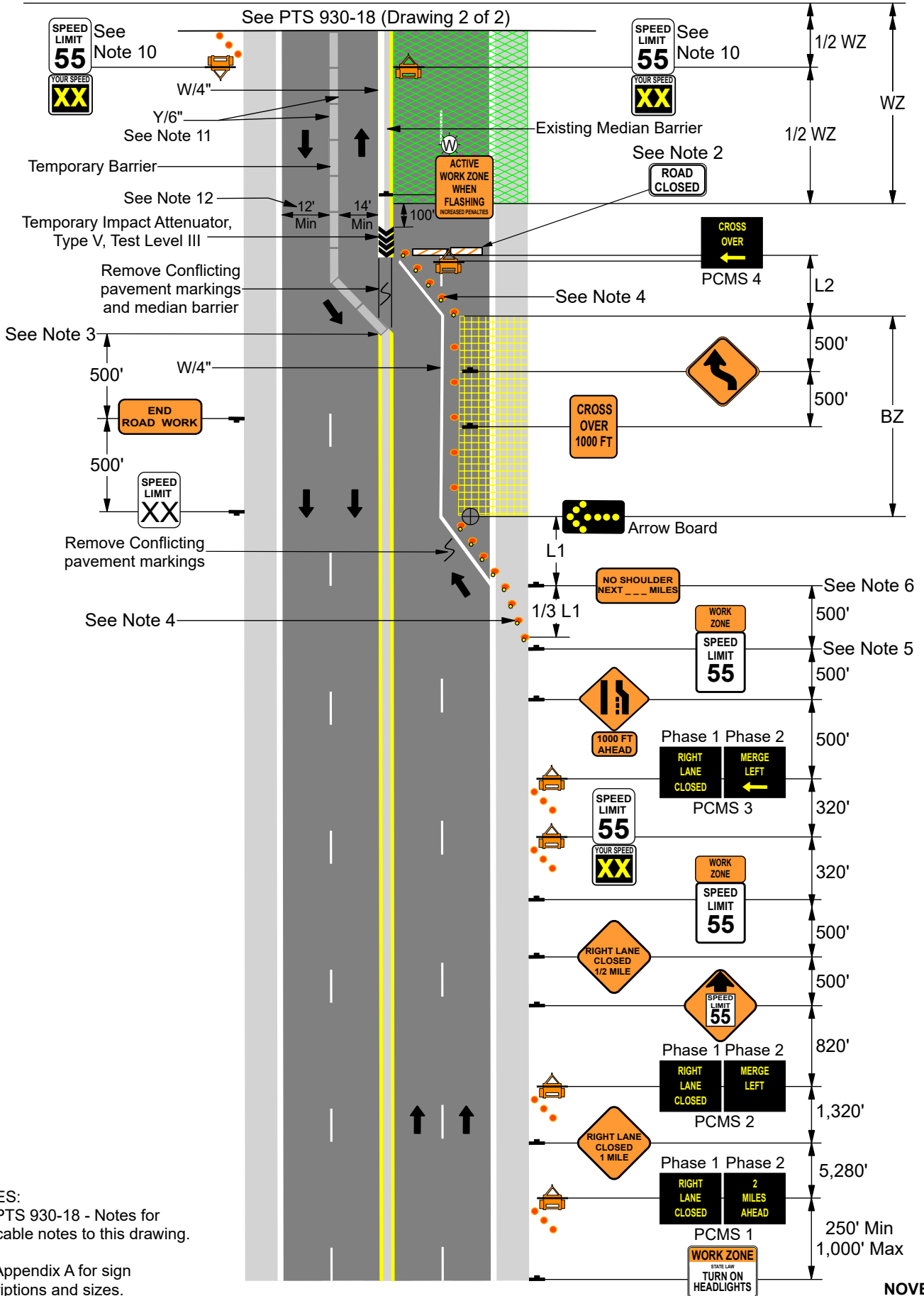

NOTES:
See PTS 930-18 - Notes for applicable notes to this drawing.
See Appendix A for sign descriptions and sizes.

PTS 930-18 Crossover Traffic Pattern Detail (Drawing 2 of 2)

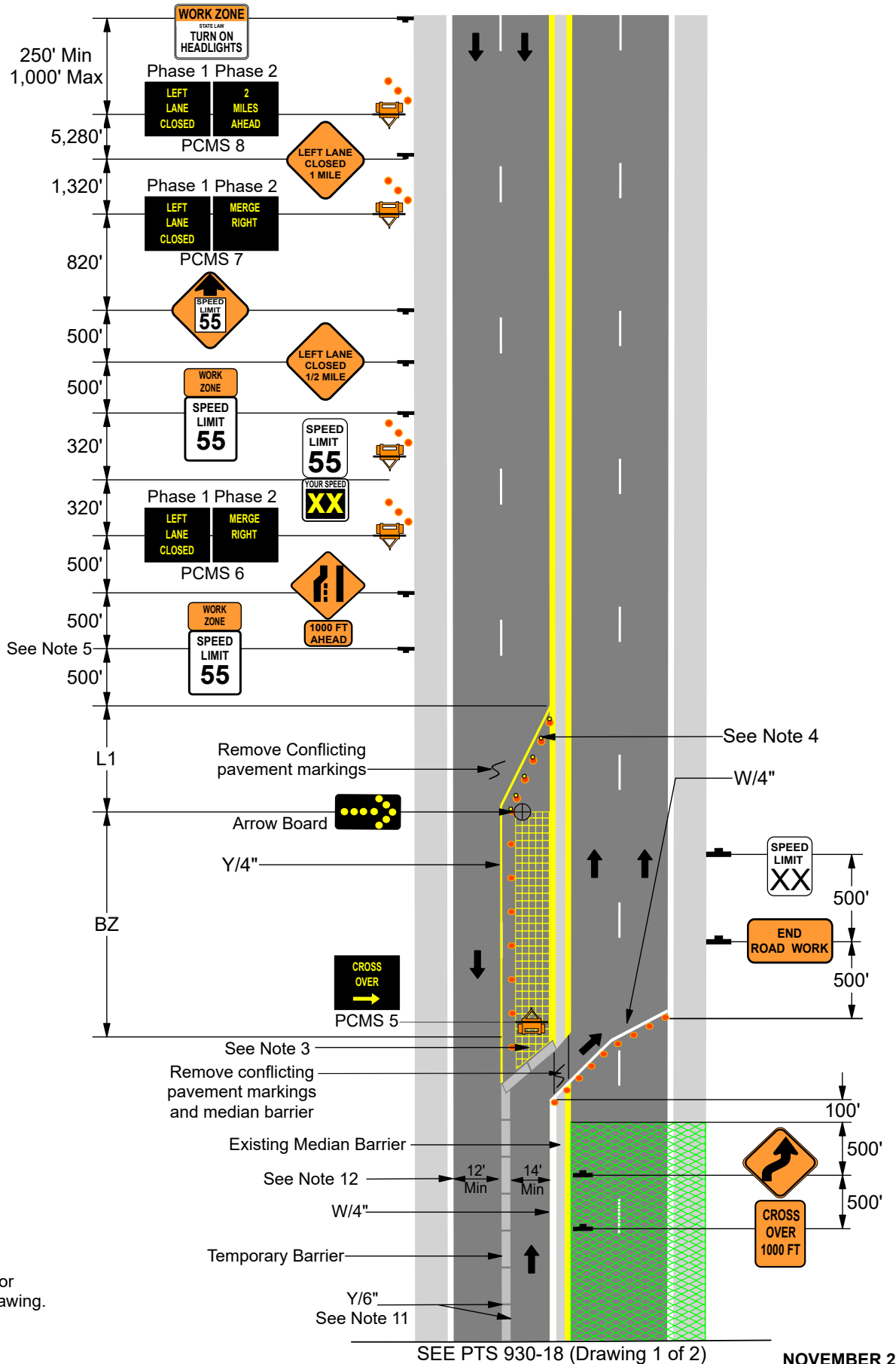

NOTES:
See PTS 930-18 - Notes for applicable notes to this drawing.

See Appendix A for sign descriptions and sizes.

SEE PTS 930-18 (Drawing 1 of 2)

NOVEMBER 2025

PTS 930-19 - Notes Emergency Pull-Off

1. Space emergency pull-offs at approximately 1 mile to the right side of traffic.
2. Emergency Pull-Off - Type II uses an existing wide area with a minimum size as indicated for Type III. Sign according to Emergency Pull-Off - Type III requirements.
3. If emergency pull-off is used by the contractor to access construction area, see PTS 930-21 Combined Emergency Pull-Off - Type I and Opening in Temporary Barrier for Access to Construction Area notes and detail.
4. Provide 6 inch temporary waterborne paint lines the full length of temporary barrier.
5. Install R5-1A sign on the back of G30-2 sign. The R5-1A , Wrong Way sign shall face opposite of traffic.
6. R6-1R signs shall only be installed on temporary barriers or permanent barriers that will be removed at the completion of the construction operation and replaced with new permanent barrier.

Signs



D12-14A



G30-1/
W30-1-3



G30-2



R5-1A



R6-1R

NOTE: See Appendix A for sign descriptions and dimensions.

PTS 930-19A Emergency Pull-Off - Type I in Temporary Barrier

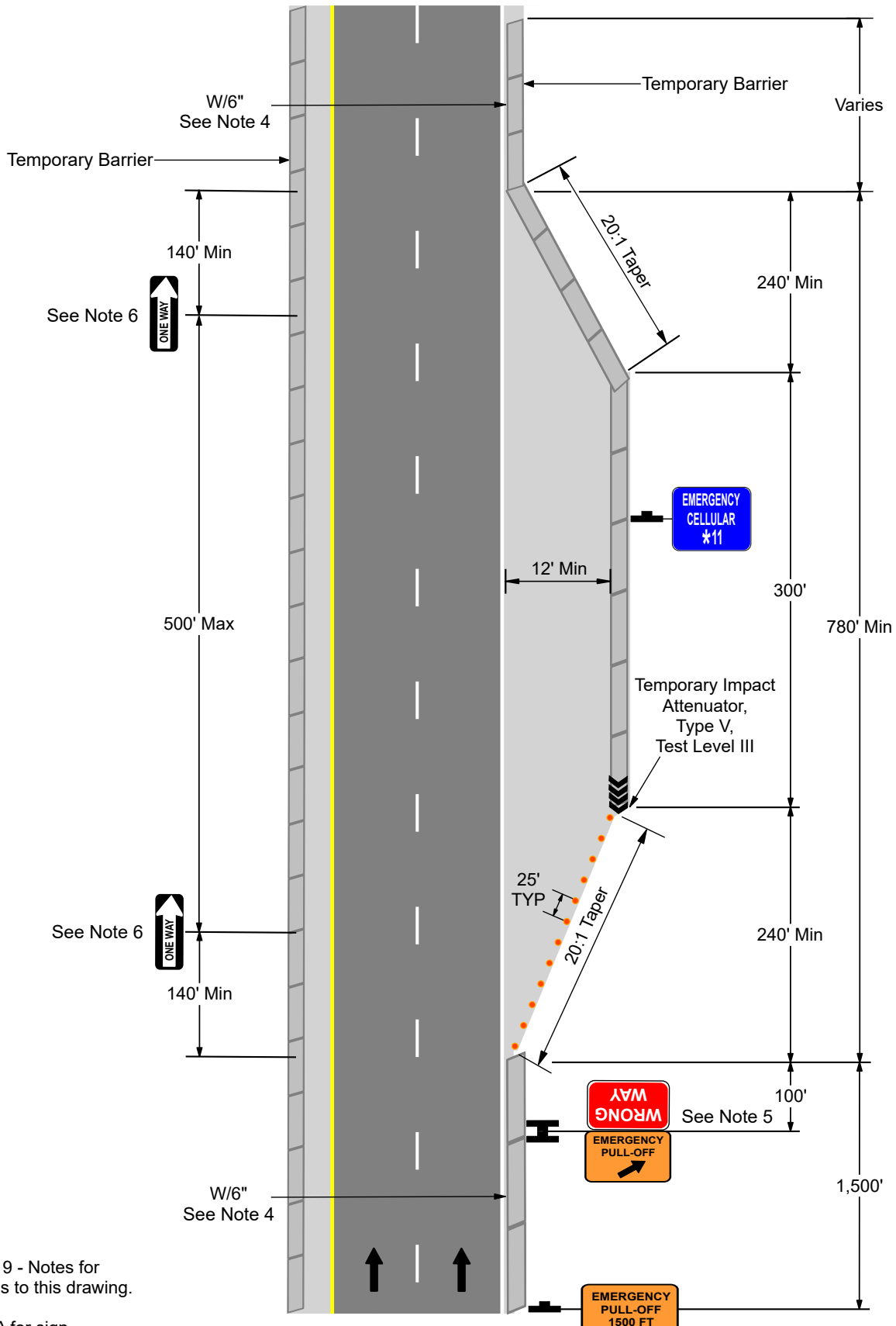

NOTES:
See PTS 930-19 - Notes for applicable notes to this drawing.

See Appendix A for sign descriptions and sizes.

PTS 930-19B Emergency Pull-Off - Type III

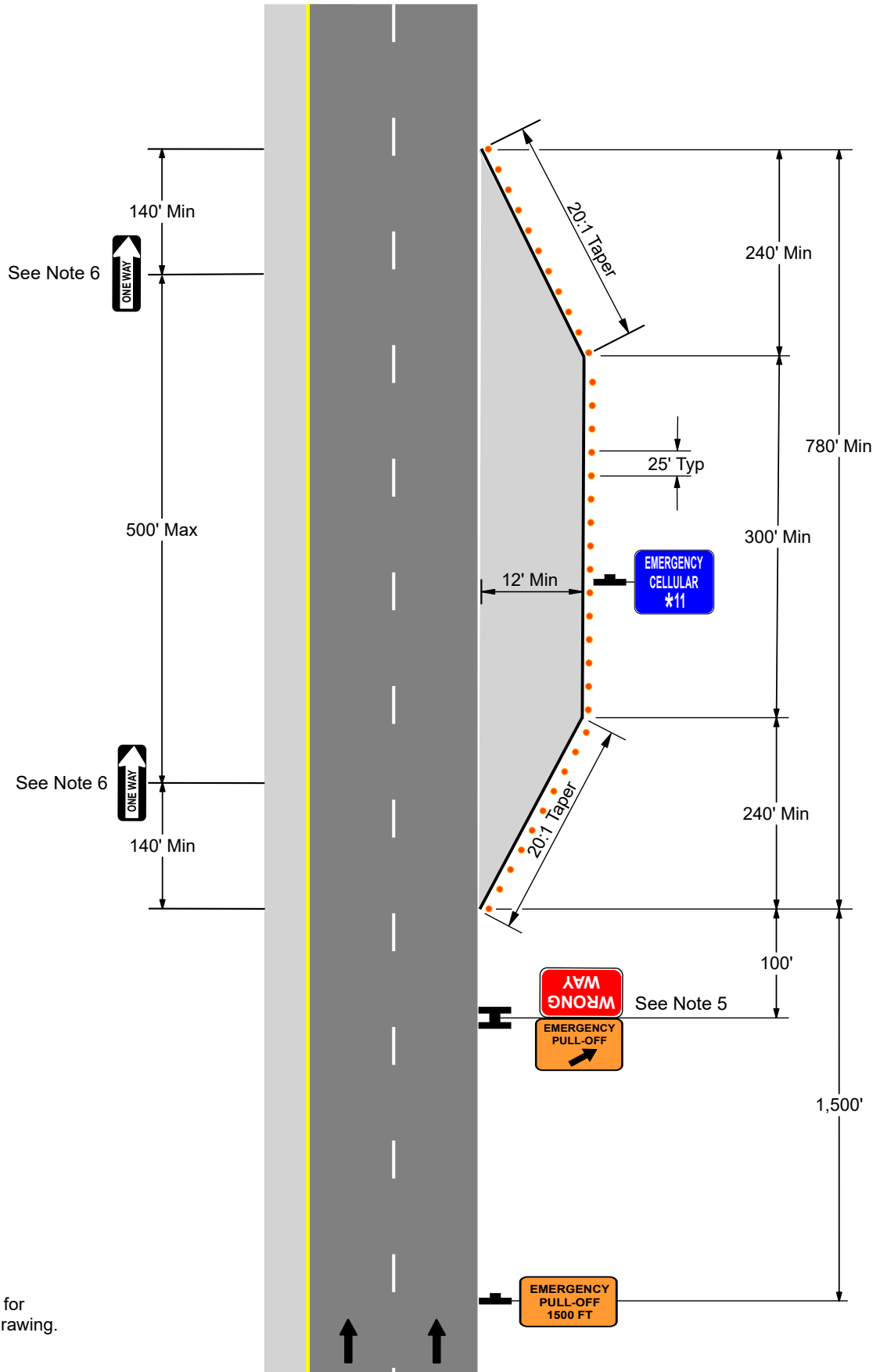

NOTES:
See PTS 930-19 - Notes for applicable notes to this drawing.

See Appendix A for sign descriptions and sizes.

PTS 930-20 - Notes

Opening in Temporary Barrier for Access to Construction Area

1. Close construction openings with temporary barrier when not required for more than two weeks. This work is incidental to the MPT.
2. Location subject to approval by Representative.
3. Station flagger at access points when access area is active. Equip flagger with PennDOT approved, like new, stop/slow paddle with entire "STOP" panel covered. Provide a platform as necessary to allow the flagger to view oncoming traffic.
4. PCMS is incidental to MPT.
5. When area is not in use for construction access for 60 minutes, place channelizing devices as shown to completely close off access to the construction area, cover signs, turn off Type B light and turn off PCMS.
6. During periods of work when the construction access is being used by work vehicles that are not trucks, change the message of the PCMS to read: Phase 1 "VEHICLES / ENTERING / AND EXITING", Phase 2 "REDUCE / SPEED / AHEAD".
7. Provide 6 inch temporary waterborne paint lines the full length of temporary barrier.
8. Install W3-5 sign only in the areas where the normal speed limit is 70 MPH, and the work zone is not reduced to 55 MPH prior to the opening in temporary barrier for access to construction area.
9. Erect the W21-19 sign and activate white Type B light when construction access areas are active. Sign shall be covered and light shall be deactivated when construction access is not in use for 60 minutes.
10. R6-1R signs shall only be installed on temporary barriers or permanent barriers that will be removed at the completion of the construction operation and replaced with new permanent barrier.

Signs

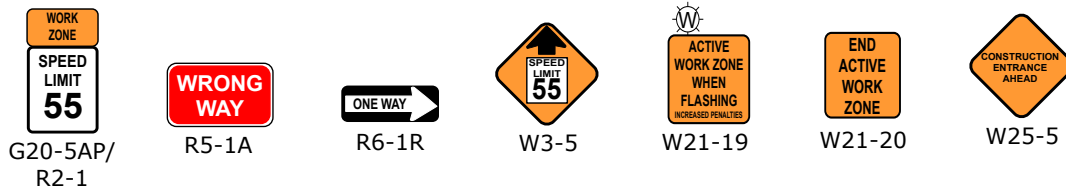

NOTE: See Appendix A for sign descriptions and dimensions.

PTS 930-20 Opening in Temporary Barrier for Access to Construction Area

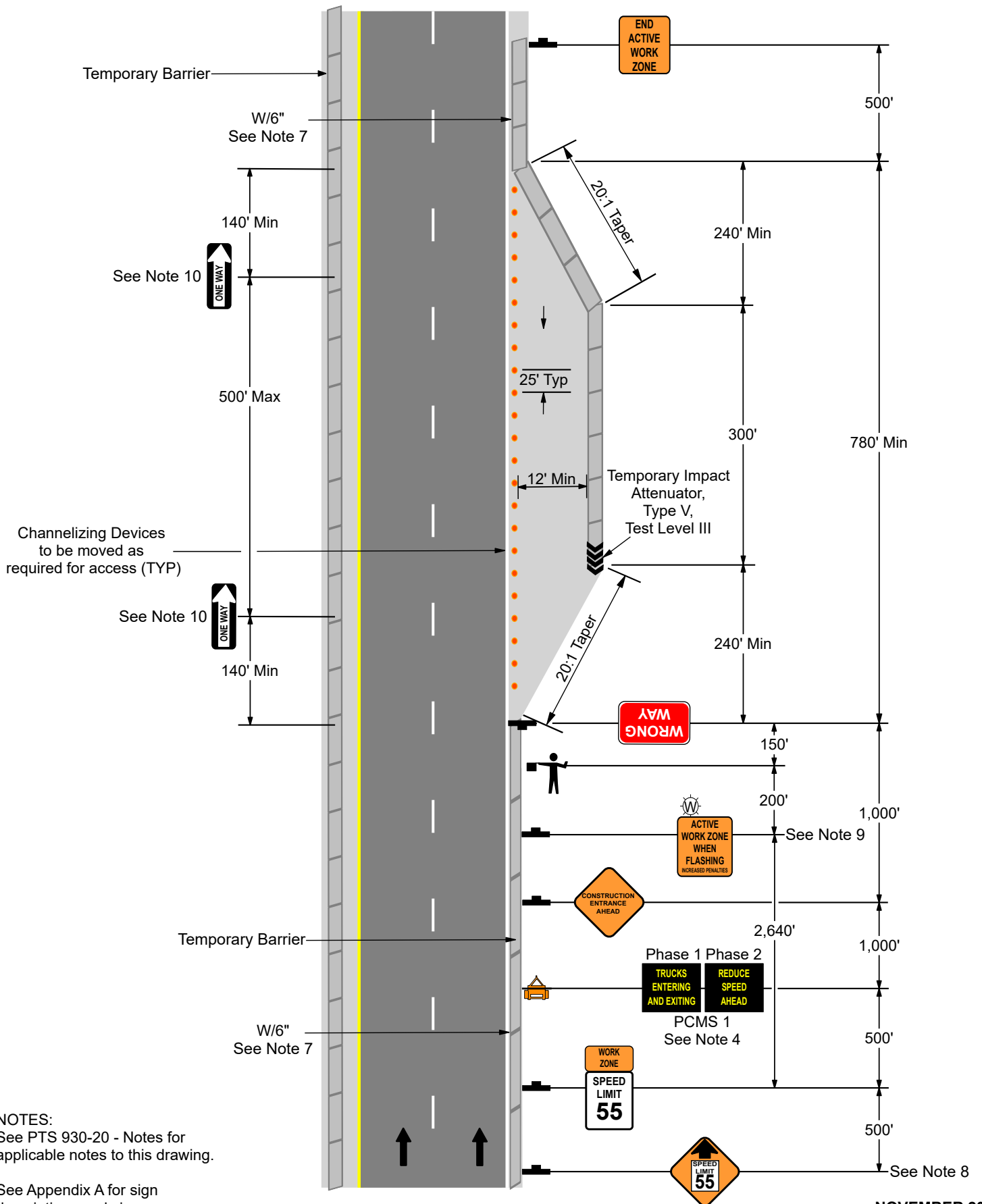

NOTES:
See PTS 930-20 - Notes for applicable notes to this drawing.

See Appendix A for sign descriptions and sizes.

PTS 930-21 - Notes

Combined Emergency Pull-Off - Type I and Opening in Temporary Barrier for Access to Construction Area

1. Space emergency pull-offs at approximately 1 mile to the right side of traffic.
2. Emergency Pull-Off - Type II uses an existing wide area with a minimum size as indicated for Type III. Sign according to Emergency Pull-Off - Type III requirements.
3. Use if emergency pull-off is used by the contractor to access construction area.
4. Show the actual distance, based on field conditions, on the sign.
5. Close construction openings with temporary barrier when not required for more than two (2) weeks. This work is incidental to the MPT.
6. Location subject to approval by Representative.
7. Station flagger at access points when access area is active. Equip flagger with PennDOT approved, like new, stop/slow paddle with entire "STOP" panel covered. Provide a platform as necessary to allow the flagger to view oncoming traffic.
8. PCMS is incidental to MPT.
9. When combined area is not in use for construction access for 60 minutes, place channelizing devices as shown to completely close off access to the construction area, cover W25-5, G20-5AP/R2-1, W21-19, and W21-20, turn off Type B light, and turn off PCMS.
10. During periods of work when the construction access is being used by work vehicles that are not trucks, change the message on the PCMS to read: Phase 1 "VEHICLES / ENTERING / AND EXITING", Phase 2 "REDUCE / SPEED / AHEAD".
11. Provide 6 inch temporary waterborne paint lines the full length of the temporary barrier.
12. Erect the W21-19 sign and activate white Type B light when construction access areas are active. Sign shall be covered and light shall be deactivated when construction access is not in use for 60 minutes.
13. R6-1R signs shall only be installed on temporary barriers or permanent barriers that will be removed at the completion of the construction operation and replaced with new permanent barrier.

Signs

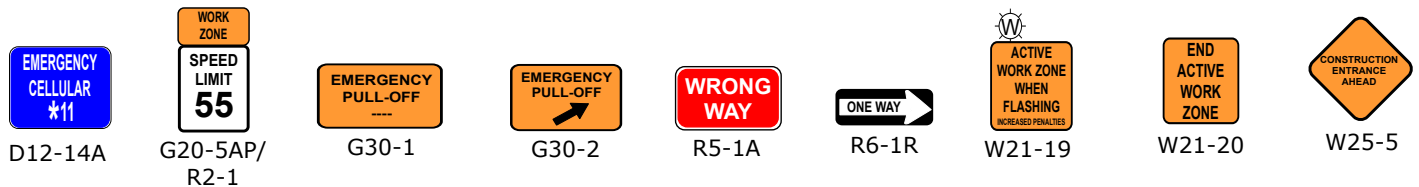

NOTE: See Appendix A for sign descriptions and dimensions.

PTS 930-21 Combined Emergency Pull-Off - Type I and Opening in Temporary Barrier for Access to Construction Area

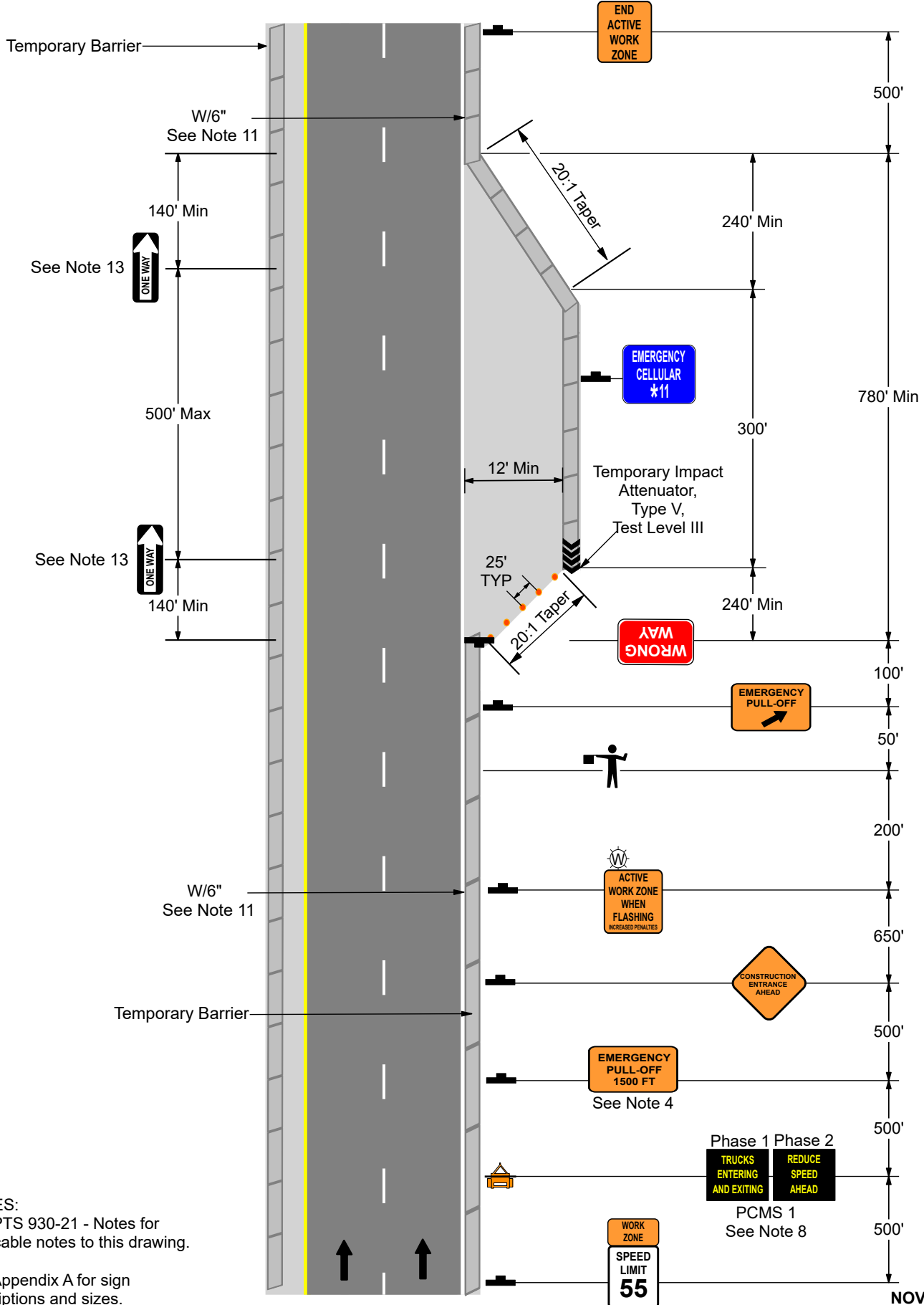

NOTES:
See PTS 930-21 - Notes for applicable notes to this drawing.

See Appendix A for sign descriptions and sizes.

PTS 930-22 - Notes

Access to Construction Area without Barrier

1. Location subject to approval by Representative.
2. PCMS is incidental to MPT.
3. During periods of work when construction access is being used by work vehicles that are not trucks, change the message of the PCMS to read: Phase 1 "VEHICLES / ENTERING / AND EXITING", Phase 2 "REDUCE / SPEED / AHEAD".
4. Acceleration from and deceleration to the construction access shall occur on the paved shoulder.
5. When access to construction area is not in use for 60 minutes, place channelizing devices as shown to completely close off the access point, cover W25-5, and turn off PCMS.
6. Access to construction area will not be permitted when all lanes are required to be available in accordance with the allowable working hours or the specified holiday restrictions. Access will only be permitted during satisfactory weather conditions as determined by the Representative.

Signs

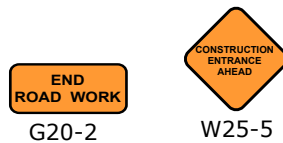

NOTE: See Appendix A for sign descriptions and dimensions.

PTS 930-22 Access to Construction Area without Barrier

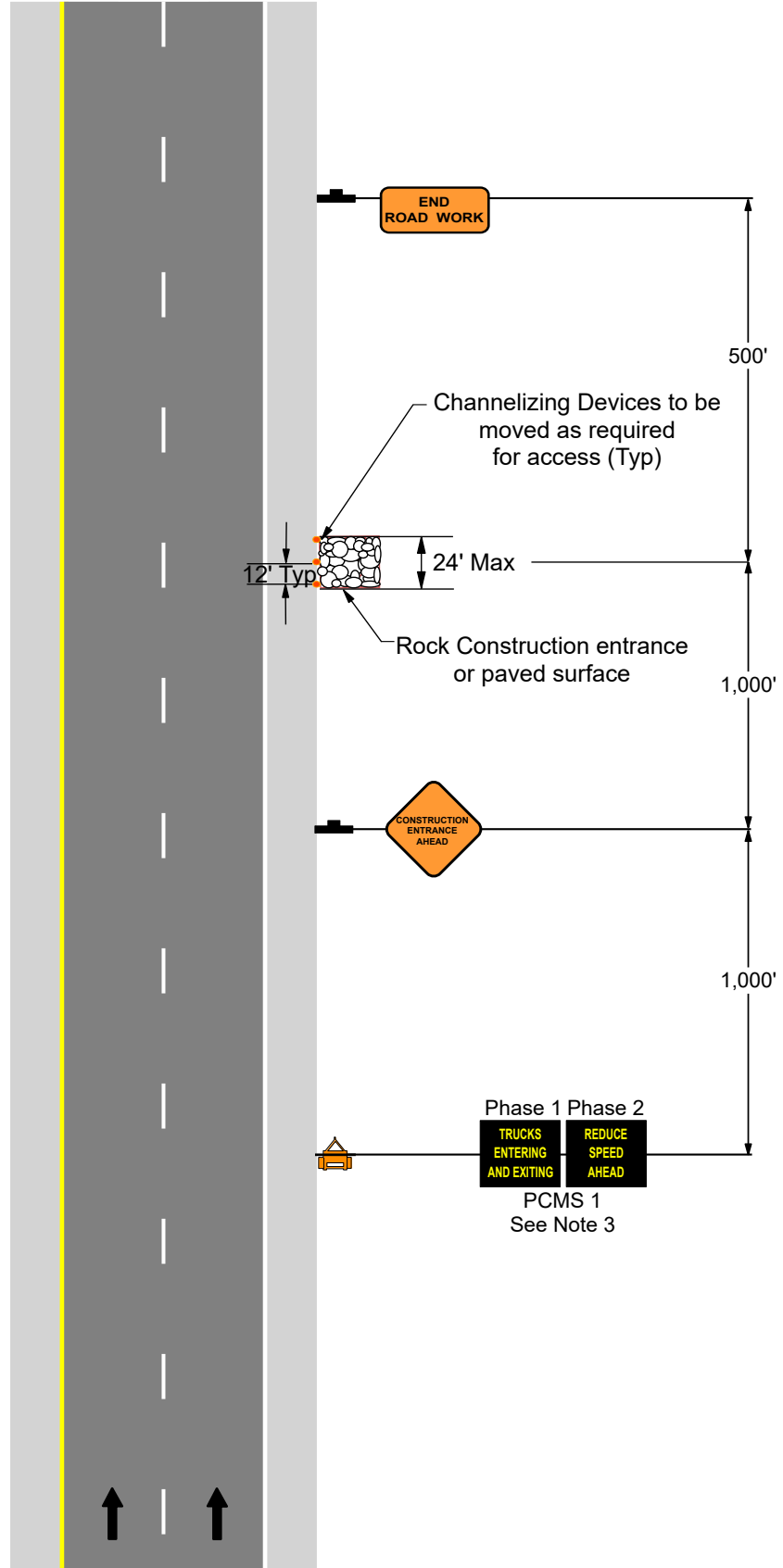

NOTES:
See PTS 930-22 - Notes for applicable notes to this drawing.

See Appendix A for sign descriptions and sizes.

PTS 930-23 - Notes

Opening in Temporary Barrier with Truck Crossing

1. Close construction openings with temporary barrier when not required for more than two (2) weeks. This work is incidental to the MPT.

2. Provide a light plant 2,000 feet in advance of flagger for truck crossings active during hours of darkness. All lanes of traffic at Light Plant 1 location must be visible to the flagger and unobstructed. Light plant shall illuminate the travel lanes at this location, but shall not be directed at oncoming traffic. Location subject to approval by the Representative.

Provide a blank 48" x 48" diamond orange sign mounted on Type III barricades 2,000 feet in advance of flagger for truck crossings active during hours of daylight. Sign is to face flagger and not be visible to oncoming traffic.

If a vehicle is between Light Plant 1 or blank sign and the crossing location, trucks are not permitted to cross the travel lanes.

3. Station flagger with light plant illuminating the flagger 150 feet in advance of access points when truck crossing is active. Flagger shall be in constant communication with any vehicles using truck crossing. Equip flagger with PennDOT approved, like new, stop/slow paddle with entire "STOP" panel covered. Provide a platform as necessary to allow the flagger to view oncoming traffic.

4. PCMS is incidental to MPT.

5. Rock construction entrances shall be placed at both sides of the roadway as shown. Additional rock to maintain the rock construction entrances shall be stockpiled on site. Rock construction entrance not required if paved surface is present.

6. When truck crossing is not in use for 60 minutes, place channelizing devices as shown to completely close off the access points, cover MPT-36, G20-5AP / R2-1, W21-19, and W21-20, turn off Type B light, and turn off PCMS.

7. Truck crossing will not be permitted when all lanes are required to be available in accordance with the allowable working hours or the specified holiday restrictions. Truck crossing will only be permitted during satisfactory weather conditions as determined by the Representative.

8. Provide 6 inch temporary waterborne paint lines the full length of temporary barrier.

9. Install W3-5 sign only in the areas where the normal speed limit is 70 MPH, and the work zone is not reduced to 55 MPH prior to the opening in temporary barrier for truck crossing.

Signs

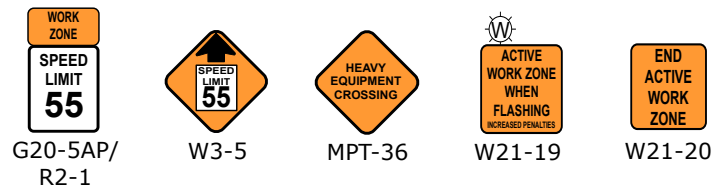

NOTE: See Appendix A for sign descriptions and dimensions.

PTS 930-23 Opening in Temporary Barrier with Truck Crossing

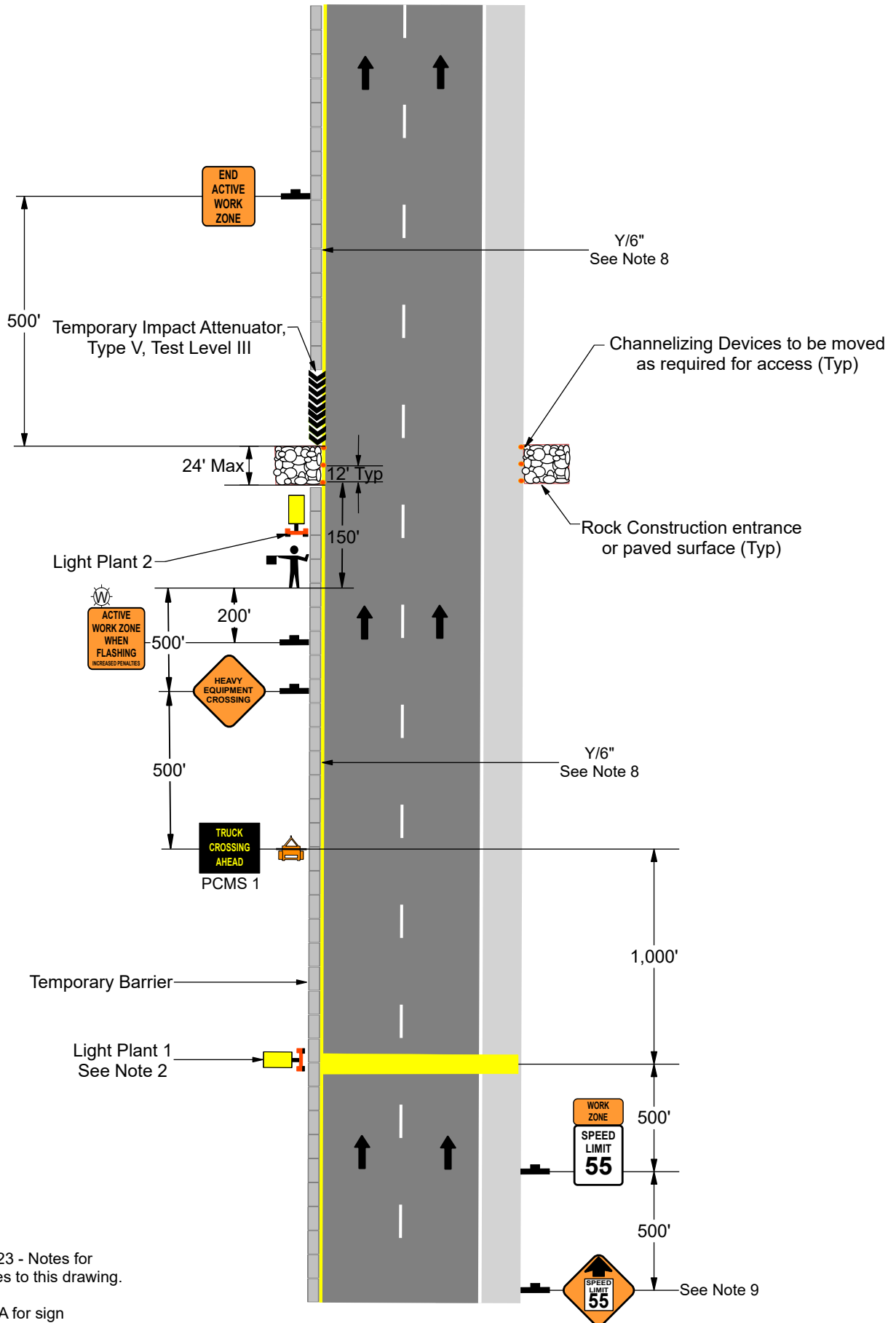

NOTES:
See PTS 930-23 - Notes for applicable notes to this drawing.

See Appendix A for sign descriptions and sizes.

Standards for Interchange Operations

(PTS 940 Series)

PTS 940-1 - Notes

Interchange Operations - General Notes

1. Remove all traffic control signs and devices immediately upon the completion of the work unless otherwise specified in the special provisions.
2. Place all traffic control devices and have them inspected by the Representative before work begins.
3. Cover or remove from the site all signs not in use. Remove from the Turnpike right-of-way construction signs not needed or used for a period of two (2) or more weeks.
4. Maintain a minimum spacing of 200 feet between all regulatory, warning and destination signs.
5. Provide at minimum a 40 feet width beyond the edge of the travel lane free of obstacles. Drop-offs greater than 2 inches in depth in work zone(s) during non-working hours shall be separated from motorists with temporary barrier. Separation of work zone(s) is incidental to the MPT.
6. Details for the signs and devices can be found in these drawings, PennDOT Publication 236, PennDOT Publication 212 and are to be manufactured by a Department of Transportation approved manufacturer as listed in PennDOT Publication 35 (Bulletin 15).
7. Use PennDOT approved Type XI reflectorized material for signs. Do not use metal or wood signs in median.
8. These standards are not intended to relieve the Contractor of the responsibility for the protection of the traveling public and construction personnel. Standards specified in Section 901.3(a) are minimum and additional measures may be needed if problems are encountered during the term of the contract.
9. Signs and devices may be adjusted to fit field conditions.
10. Concrete barrier details are to be according to PennDOT Standards for Roadway Construction, RC-57M, RC-59M, and PTC Standards for Roadway Construction.
11. Only traffic control devices are permitted within the buffer zone. Do not locate vehicles, equipment, material, or workers in this area.
12. Type B light is to be mounted on the side closest to traffic as shown on PTS 980.
13. Type B yellow flashing warning lights may be used in conjunction with warning signs, unless otherwise indicated on the drawing.
14. Channelizing devices may be temporarily relocated to the minimum offset to allow for work to be performed, as directed by the Representative. The channelizing devices must remain between traffic and the work zone. Relocate channelizing devices to original position as work progresses.
15. Install, reset, relocate, remove any permanent and/or temporary barrier so that no blunt end of the barrier is exposed to oncoming traffic.

PTS 940-2 - Notes

Toll Plaza Right Lane Closure Operations Less Than 8 Hours

1. Use only for short-term operations which occupy a location for less than 8 hours.
2. Overhead lane control to display red signal, close toll lane gate, and white on red background "Lane Closed" sign mounted on lane gate to be visible to traffic, if available.
3. Completely close off access to parking lot using channelizing devices.
4. Channelizing devices spaced at 10 feet except where noted.
5. Increase taper length at toll plaza based on number of lanes closed.
6. Right lane closure operations will not be permitted when all lanes are required to be available in accordance with the allowable working hours or the specified holiday restrictions.

Signs



PTC-LC

NOTE: See Appendix A for sign descriptions and dimensions.

**PTS 940-2
Toll Plaza Right Lane Closure
Operations Less Than 8 Hours**

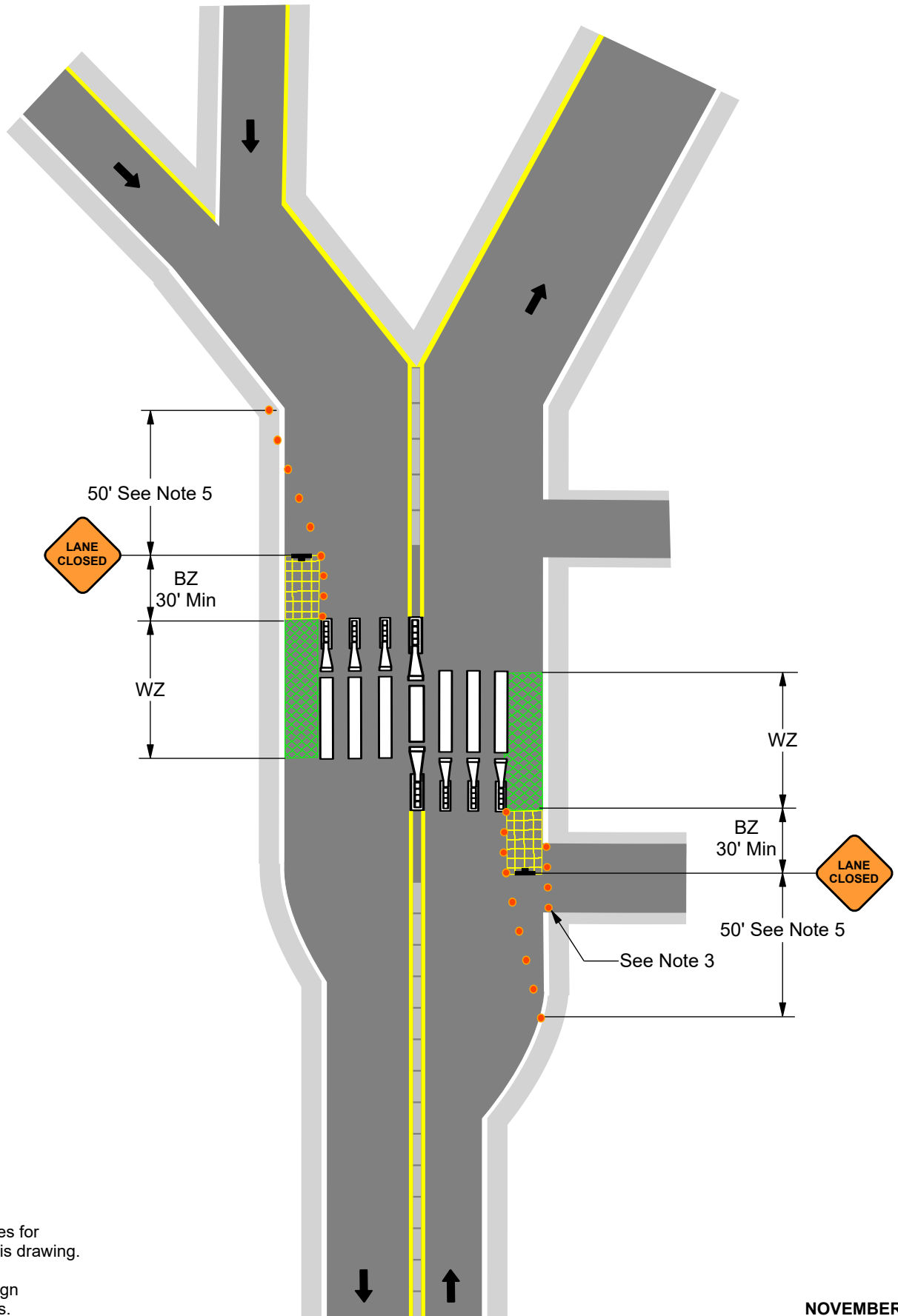

NOTES:
See PTS 940-2 - Notes for applicable notes to this drawing.

See Appendix A for sign descriptions and sizes.

PTS 940-3 - Notes Toll Plaza Right Lane Closure Operations Between 8 and 72 Hours

1. Use only for short-term operations which occupy a location for 8 to 72 hours.
2. Overhead lane control to display red signal, close toll lane gate, and white on red background "Lane Closed" sign mounted on lane gate to be visible to traffic, if available.
3. Completely close off access to parking lot using channelizing devices.
4. If multiple ramps provide entrance to toll plaza, place PTC-LCA signs on each ramp as necessary.
5. Channelizing devices spaced at 10 feet except where noted.
6. Increase taper length at toll plaza based on number of lanes closed.
7. Right lane closure operations will not be permitted when all lanes are required to be available in accordance with the allowable working hours or the specified holiday restrictions.

Signs



NOTE: See Appendix A for sign descriptions and dimensions.

**PTS 940-3
Toll Plaza Right Lane Closure
Operations Between 8 and 72 Hours**

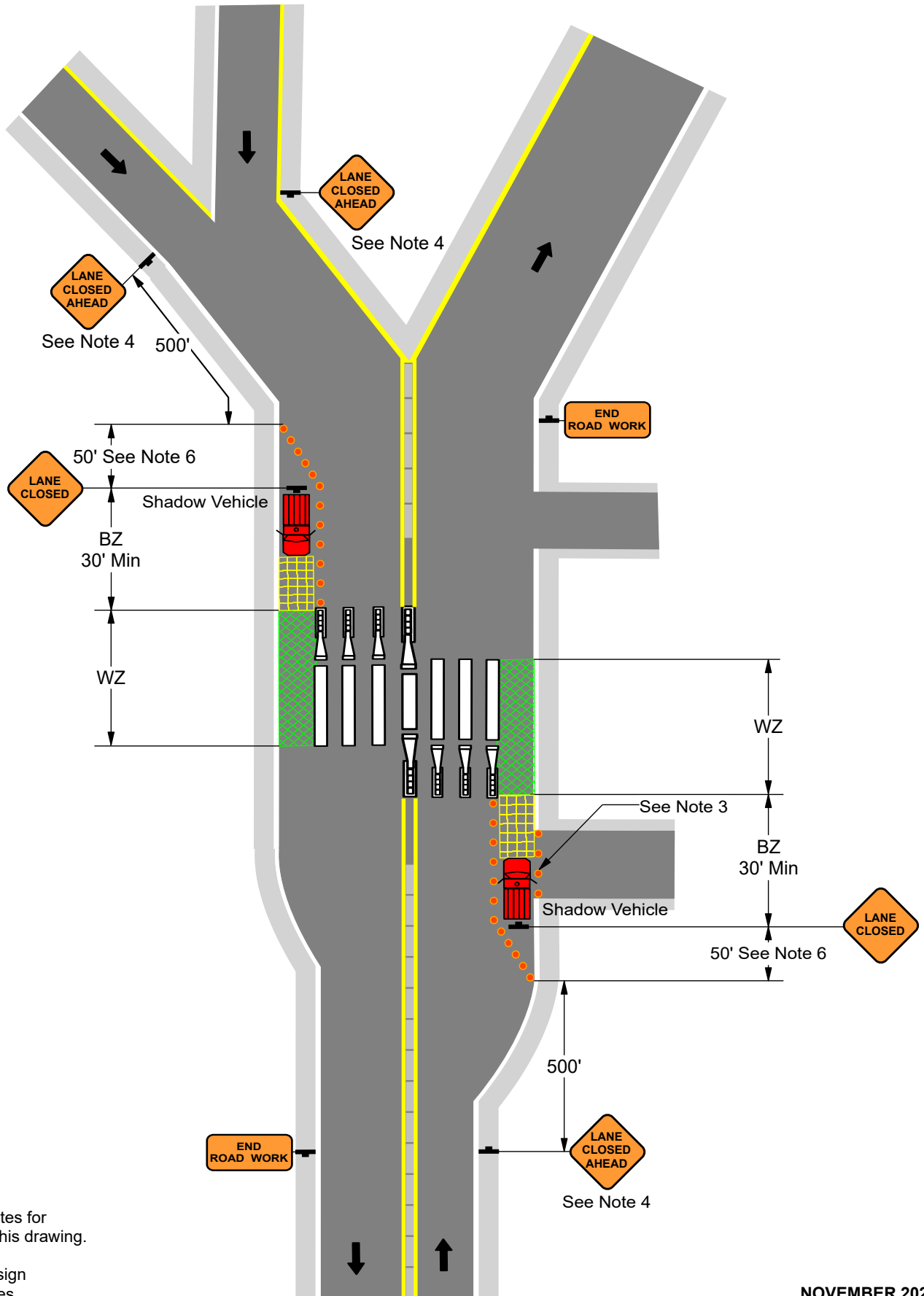

NOTES:
See PTS 940-3 - Notes for applicable notes to this drawing.

See Appendix A for sign descriptions and sizes.

PTS 940-4 - Notes

Toll Plaza Right Lane Closure Operations More Than 72 Hours

1. Use only for long-term operations which occupy a location for more than 72 hours.
2. Overhead lane control to display red signal, close toll lane gate, and white on red background "Lane Closed" sign mounted on lane gate to be visible to traffic, if available.
3. If distance to intersecting roadway does not allow sign placement as shown, place MPT-10 sign 50 feet minimum from intersection to roadway and space PTC-LCA sign equally between MPT-10 and beginning of taper.
4. Completely close off access to parking lot using channelizing devices.
5. If multiple ramps provide entrance to toll plaza, place MPT-10 and PTC-LCA signs on each ramp as necessary.
6. Channelizing devices spaced at 10 feet except where noted.
7. Increase taper length at toll plaza based on number of lanes closed.
8. Right lane closure operations will not be permitted when all lanes are required to be available in accordance with the allowable working hours or the specified holiday restrictions.

Signs

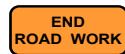

G20-2



MPT-10



PTC-LCA

NOTE: See Appendix A for sign descriptions and dimensions.

PTS 940-4 Toll Plaza Right Lane Closure Operations More Than 72 Hours

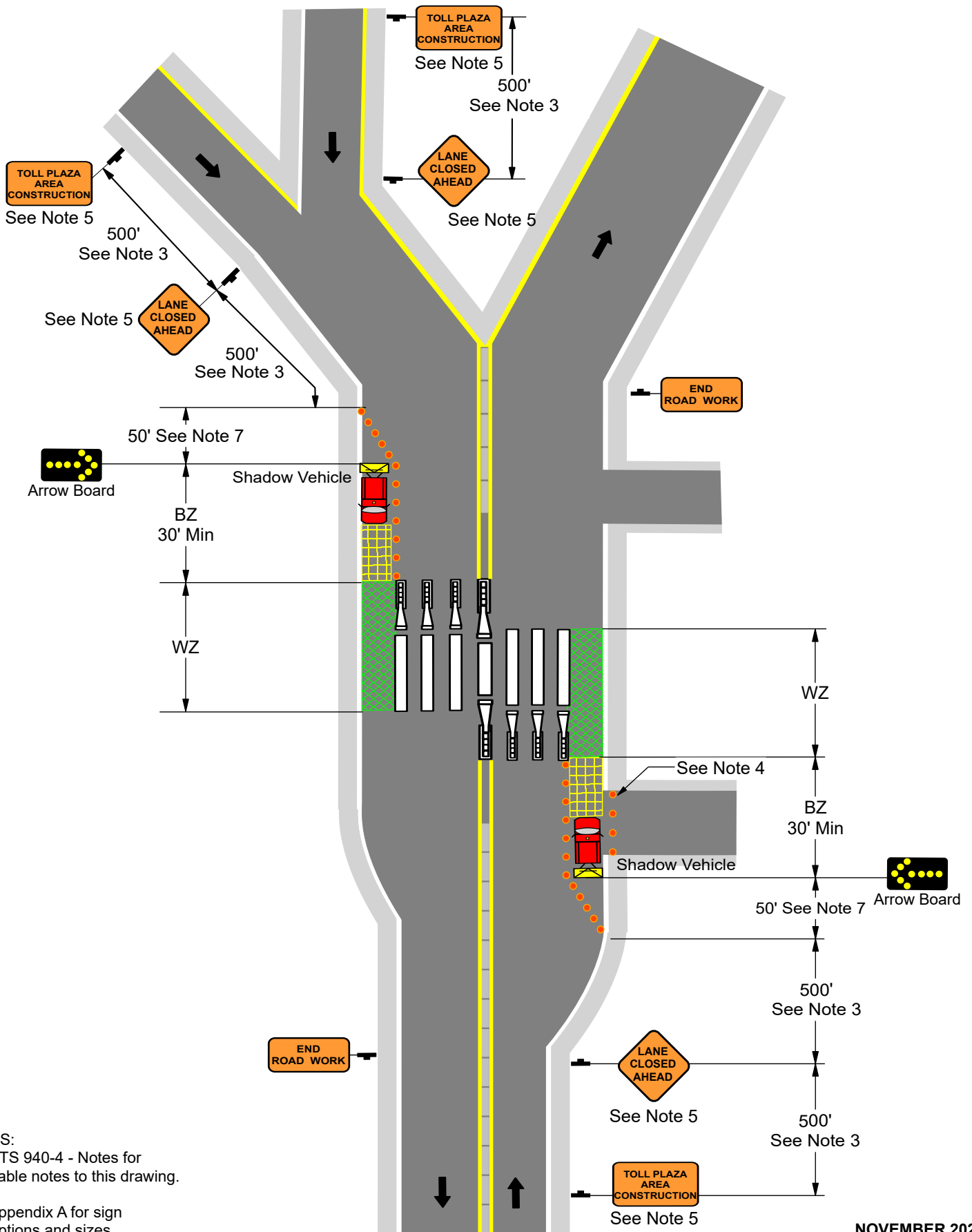

NOTES:
See PTS 940-4 - Notes for applicable notes to this drawing.

See Appendix A for sign descriptions and sizes.

PTS 940-5 - Notes Toll Plaza Center Lane Closure Operations Less Than 8 Hours

1. Use only for short-term operations which occupy a location for less than 8 hours
2. Overhead lane control to display red signal, close toll lane gate, and white on red background "Lane Closed" sign mounted on lane gate to be visible to traffic, if available.
3. Channelizing devices spaced at 10 feet except where noted.
4. Increase taper length at toll plaza based on number of lanes closed.
5. Center lane closure operations will not be permitted when all lanes are required to be available in accordance with the allowable working hours or the specified holiday restrictions.

Signs



PTC-LC

NOTE: See Appendix A for sign descriptions and dimensions.

**PTS 940-5
Toll Plaza Center Lane Closure
Operations Less Than 8 hours**

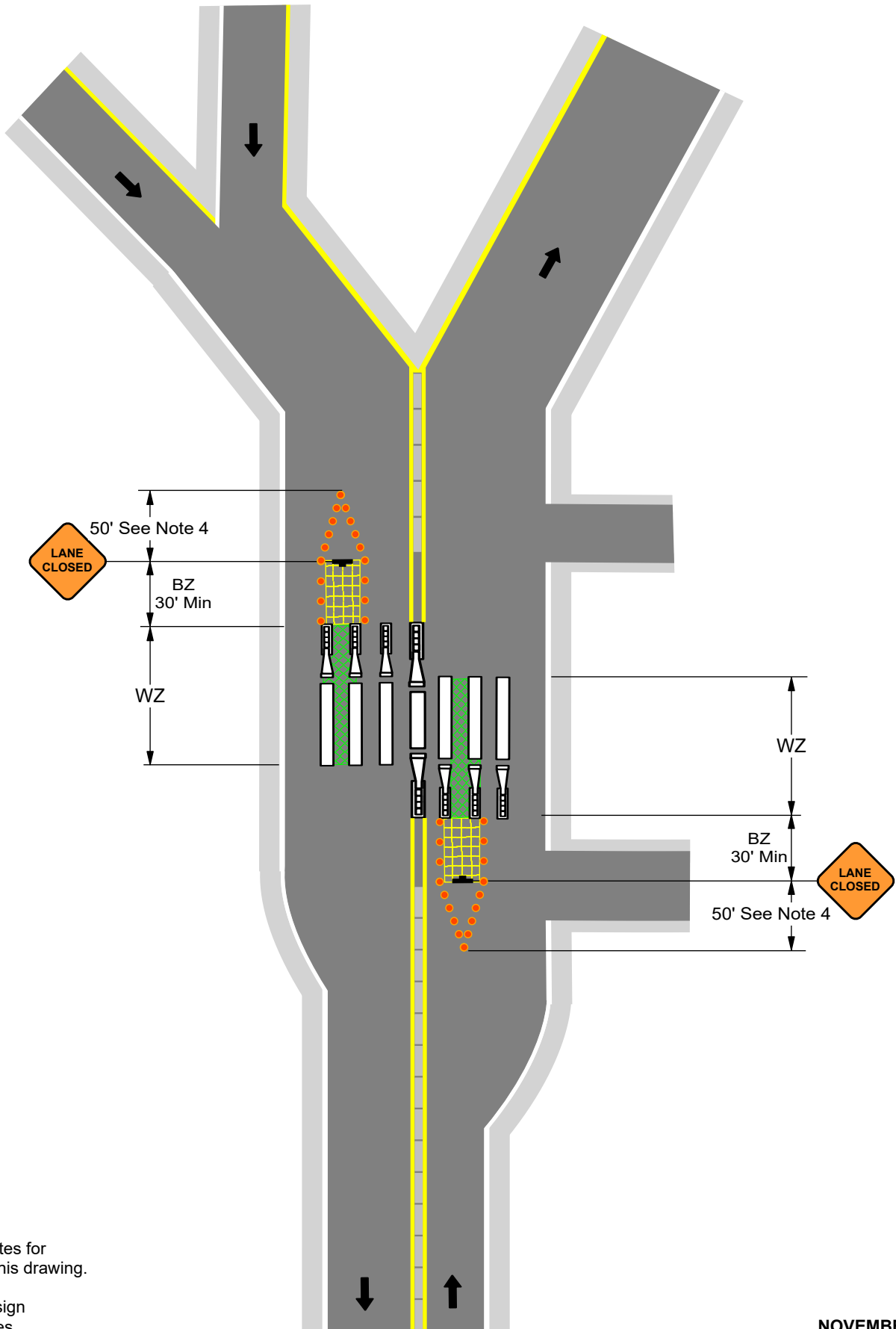

NOTES:
See PTS 940-5 - Notes for
applicable notes to this drawing.

See Appendix A for sign
descriptions and sizes.

PTS 940-6 - Notes
Toll Plaza Center Lane Closure
Operations Between 8 and 72 Hours

1. Use only for short-term operations which occupy a location for 8 to 72 hours.
2. Overhead lane control to display red signal, close toll lane gate, and white on red background "Lane Closed" sign mounted on lane gate to be visible to traffic, if available.
3. If multiple ramps provide entrance to toll plaza, place PTC-LCA signs on each ramp as necessary.
4. Channelizing devices spaced at 10 feet except where noted.
5. Increase taper length at toll plaza based on number of lanes closed.
6. Center lane closure operations will not be permitted when all lanes are required to be available in accordance with the allowable working hours or the specified holiday restrictions.

Signs



NOTE: See Appendix A for sign descriptions and dimensions.

**PTS 940-6
Toll Plaza Center Lane Closure
Operations Between 8 and 72 Hours**

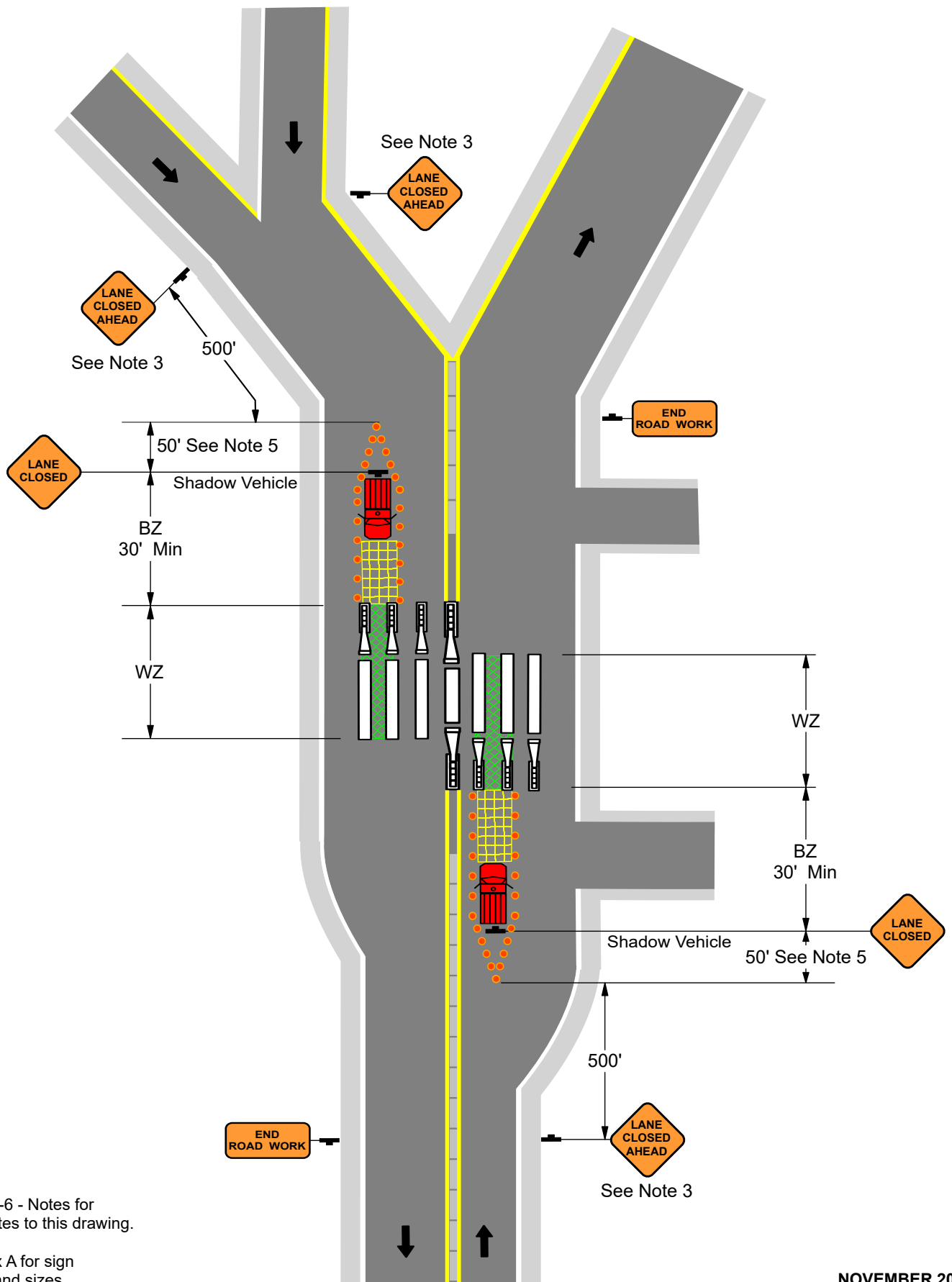

NOTES:
See PTS 940-6 - Notes for applicable notes to this drawing.

See Appendix A for sign descriptions and sizes.

PTS 940-7 - Notes Toll Plaza Center Lane Closure Operations More than 72 Hours

1. Use only for long-term operations which occupy a location for more than 72 hours.
2. Overhead lane control to display red signal, close toll lane gate, and white on red background "Lane Closed" sign mounted on lane gate to be visible to traffic, if available.
3. If distance to intersecting roadway does not allow sign placement as shown, place MPT-10 sign 50 feet minimum from intersection to roadway and space PTC-LCA sign equally between MPT-10 and beginning of taper.
4. If multiple ramps provide entrance to toll plaza, place MPT-10 and PTC-LCA signs on each ramp as necessary.
5. Channelizing devices spaced at 10 feet except where noted.
6. Increase taper length at toll plaza based on number of lanes closed.
7. Center lane closure operations will not be permitted when all lanes are required to be available in accordance with the allowable working hours or the specified holiday restrictions.

Signs

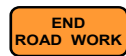

G20-2



MPT-10



PTC-LCA

NOTE: See Appendix A for sign descriptions and dimensions.

PTS 940-7 Toll Plaza Center Lane Closure Operations More than 72 Hours

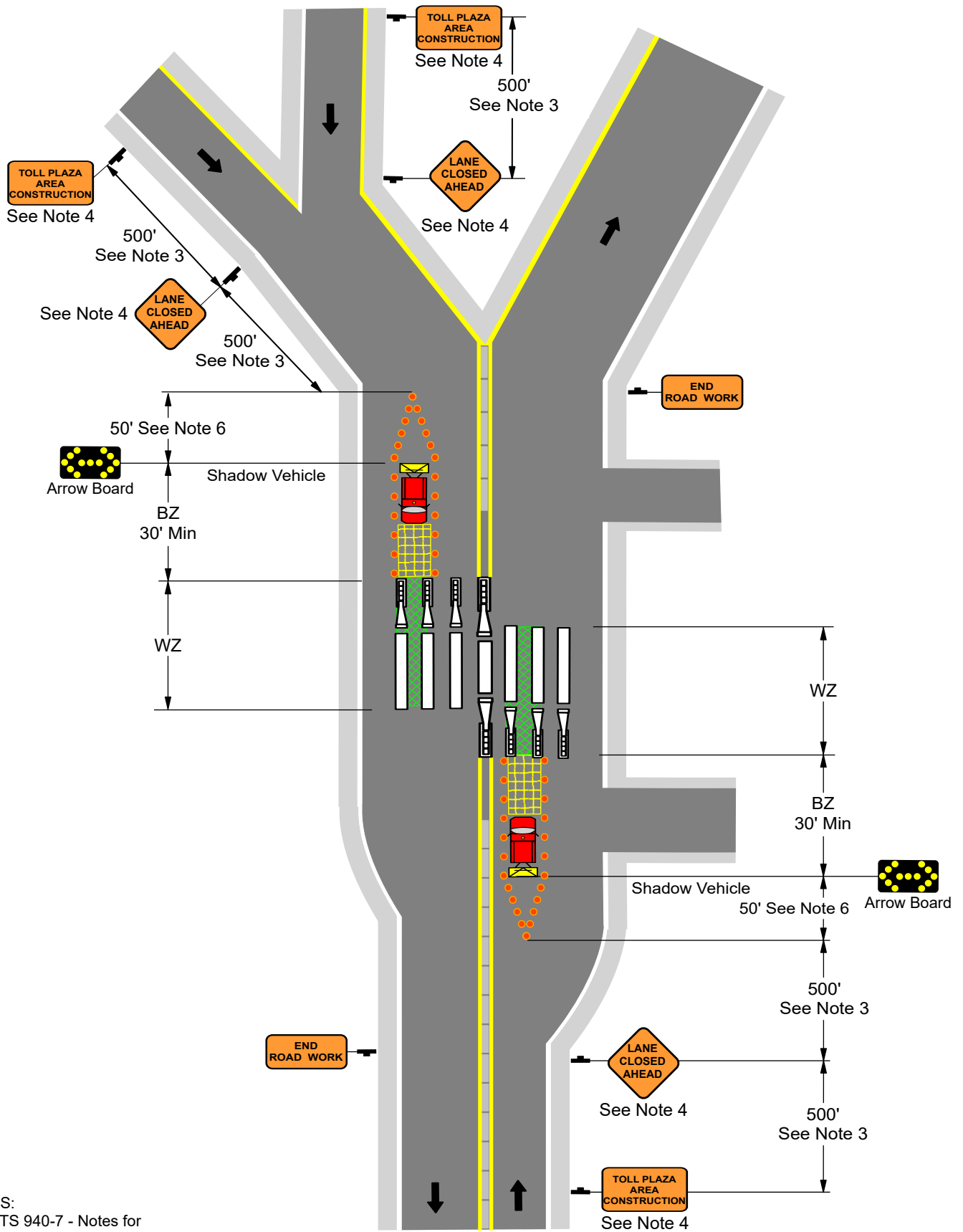

NOTES:
See PTS 940-7 - Notes for applicable notes to this drawing.

See Appendix A for sign descriptions and sizes.

PTS 940-8 - Notes

Advance Warning Signs for Work on Ramps

1. Place PCMS a minimum of 500 feet in advance of ramp or 500 feet in advance of W21-101 sign, whichever is greater.
2. Place W20-7 signs on every other toll island, if applicable.

Signs



NOTE: See Appendix A for sign descriptions and dimensions.

PTS 940-8 Advance Warning Signs for Work on Ramps

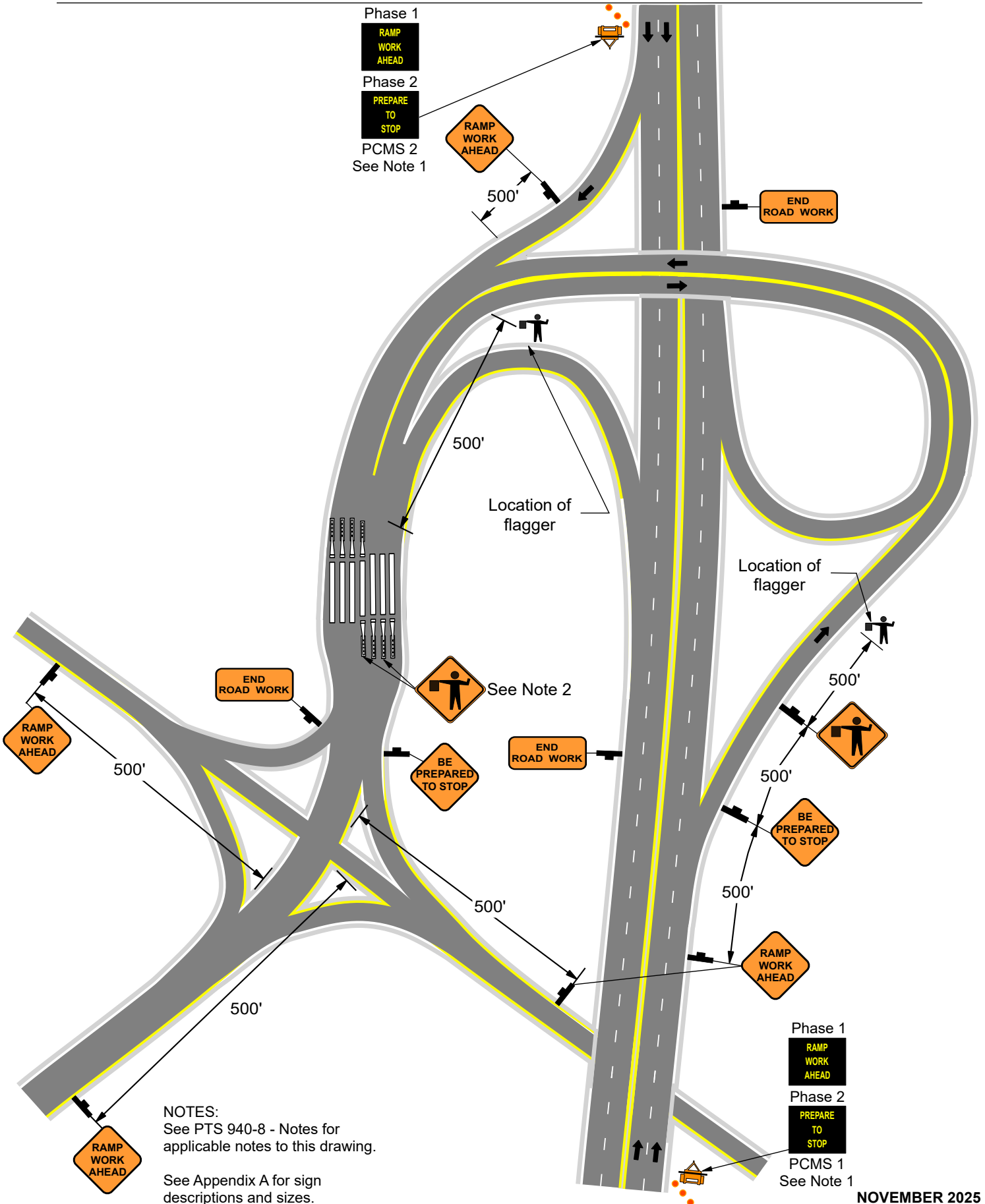

NOTES:
See PTS 940-8 - Notes for applicable notes to this drawing.
See Appendix A for sign descriptions and sizes.

Phase 1
RAMP WORK AHEAD
Phase 2
PREPARE TO STOP
PCMS 1
See Note 1

PTS 940-9 - Notes

Service Plaza Area Construction

1. This pattern to be used for work within Service Plaza parking areas. For any work on Service Plaza ramps, use PTS 940-10, PTS 940-11A or PTS 940-11B, as applicable.
2. Place PCMS a minimum of 500 feet in advance of ramp or 500 feet in advance of W21-101 sign, whichever is greater.

Signs



G20-2



W21-102

NOTE: See Appendix A for sign descriptions and dimensions.

PTS 940-9 Service Plaza Area Construction

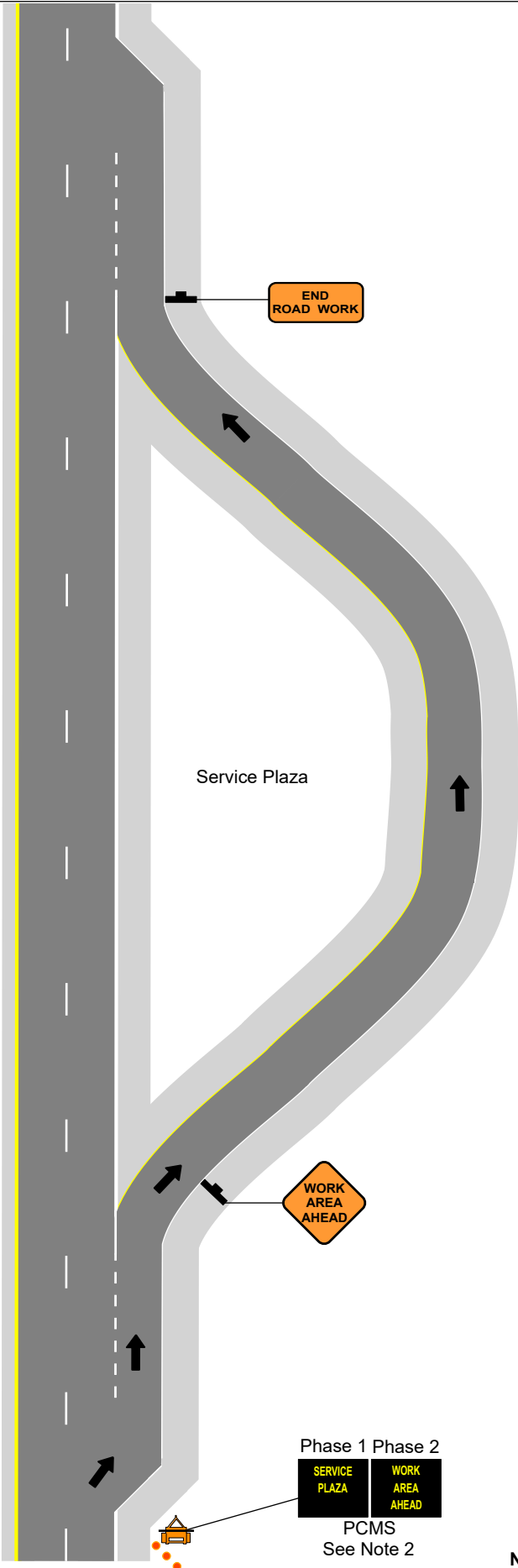

NOTES:
See PTS 940-9 - Notes for applicable notes to this drawing.

See Appendix A for sign descriptions and sizes.

Phase 1 Phase 2
SERVICE PLAZA WORK AREA AHEAD
PCMS
See Note 2

PTS 940-10 - Notes Ramp Bridge Crossover

1. Place channelizing devices at 10 feet apart to close off barrier opening during non-working hours.
2. Compute the minimum desirable merging taper length for reduction in lanes on ramps using the following formula:

$$L = \frac{W \times S_N^2}{60}$$

Where L = Minimum desirable merging taper length in feet
W = Width of offset in feet
S_N = Normal speed in miles per hour

Signs



W21-10

NOTE: See Appendix A for sign descriptions and dimensions.

PTS 940-10 Ramp Bridge Crossover

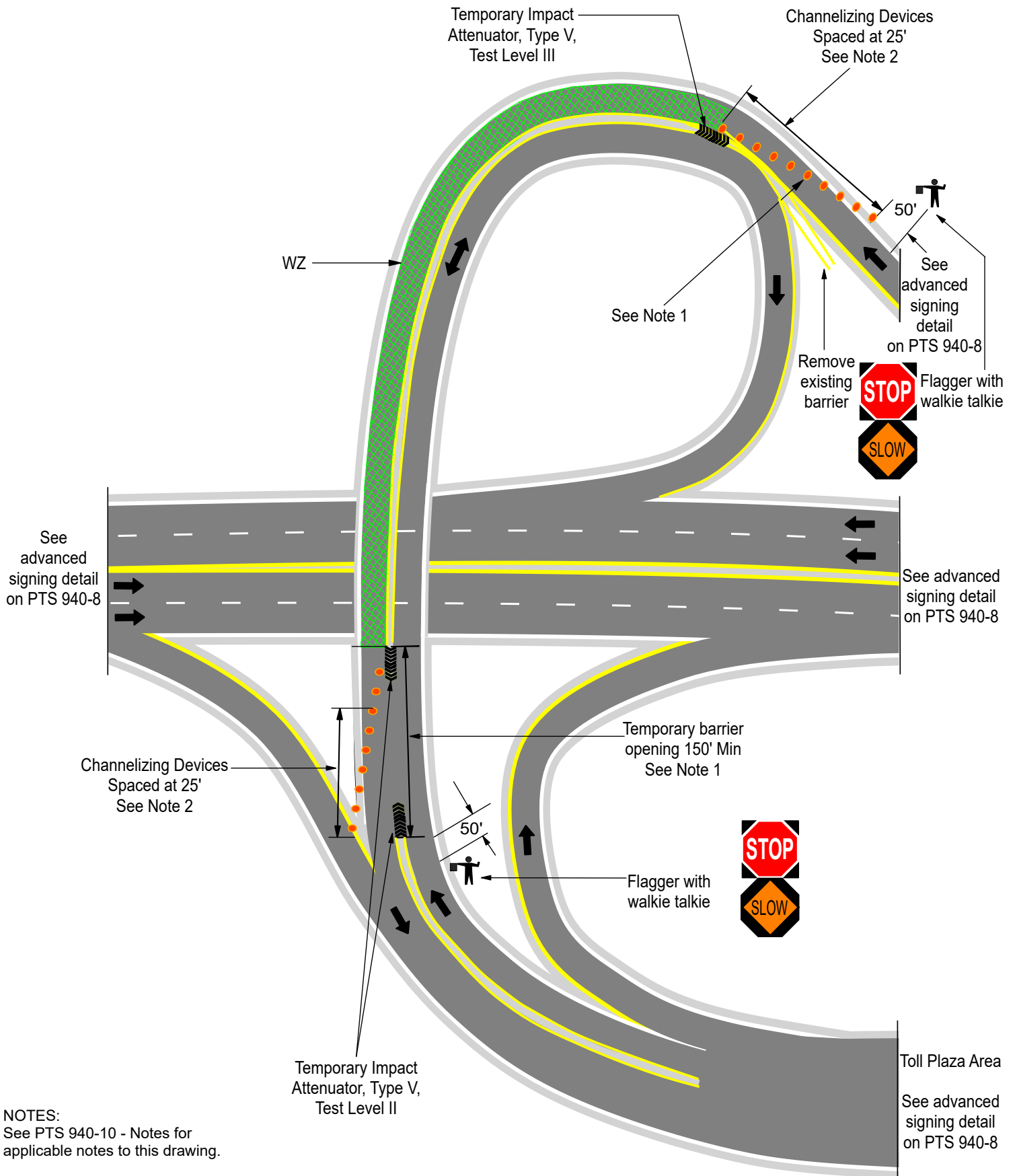

NOTES:
See PTS 940-10 - Notes for applicable notes to this drawing.

See Appendix A for sign descriptions and sizes.

PTS 940-11 - Notes

Work Zone on Ramp with Channelizing Devices

1. Use channelizing devices with PennDOT approved sequential warning lights in the taper areas for patterns used during hours of darkness.
2. Compute the minimum desirable merging taper length or shoulder taper length (1/3L) using the following formula (Verify speed to be used with PTC Traffic Engineering unit):

$$L = \frac{W \times S_N^2}{60} \quad \text{Use for } S_N = 40 \text{ MPH or less.}$$

$$L = W \times S_N \quad \text{Use for } S_N > 40 \text{ MPH.}$$

Where L = Minimum desirable merging taper length in feet
W = Width of offset in feet
S_N = Normal speed in miles per hour

3. All arrow boards are to be truck-mounted or trailer-mounted and attached to the truck and shall move with the associated shadow vehicle.
4. Work zone on ramp with channelizing devices will not be permitted when all lanes are required to be available in accordance with the allowable working hours or the specified holiday restrictions.
5. Place PCMS a minimum of 500 feet in advance of ramp or 500 feet in advance of W21-101 sign, whichever is greater.
6. W21-19 is not required for PTC Maintenance Division Operations.
7. For work on left side of ramp, use the same sign spacing, location, and pattern but with the signs and PCMS indicating a work zone on the left side.
8. Truck turning movement must be performed to verify a 14'-0" minimum travel lane will be adequate for WB-67 vehicle to safely traverse the ramp through the work zone.

Signs

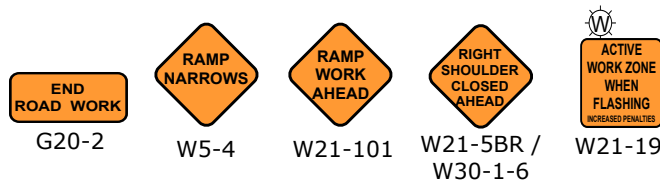

NOTE: See Appendix A for sign descriptions and dimensions.

Distance and Spacing Quick Reference Chart

SPEED	L	1/3 L	BZ	RA	WZ	R	Maximum Channelizing Device Spacing (Feet)		
							L & 1/3L	BZ, RA & WZ	R
MPH	Feet	Feet	Feet	Feet	Mile(s)	Feet			
Varies	Varies	Varies	100	250	Varies	50	25	25	25

L = Merging Taper
1/3L = Shoulder Taper
BZ = Buffer Zone
RA = Roll Ahead Space
WZ = Work Zone
R = Runout

PTS 940-11A Stationary Shoulder Closure on Ramp with Channelizing Devices

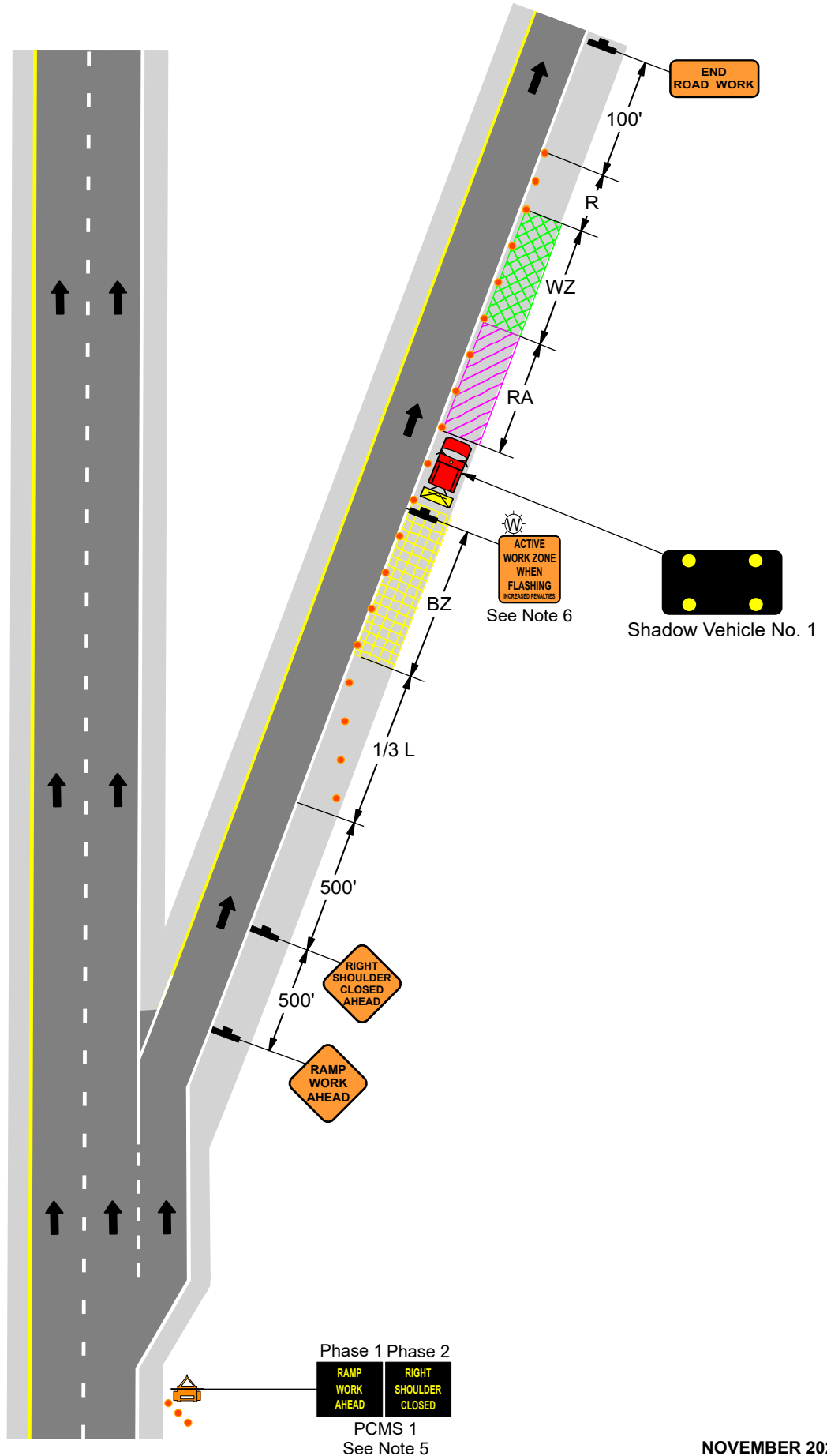

NOTES:
 See PTS 940-11 - Notes for applicable notes to this drawing.

See Appendix A for sign descriptions and sizes.

PTS 940-11B Lane Narrows on Ramp with Channelizing Devices

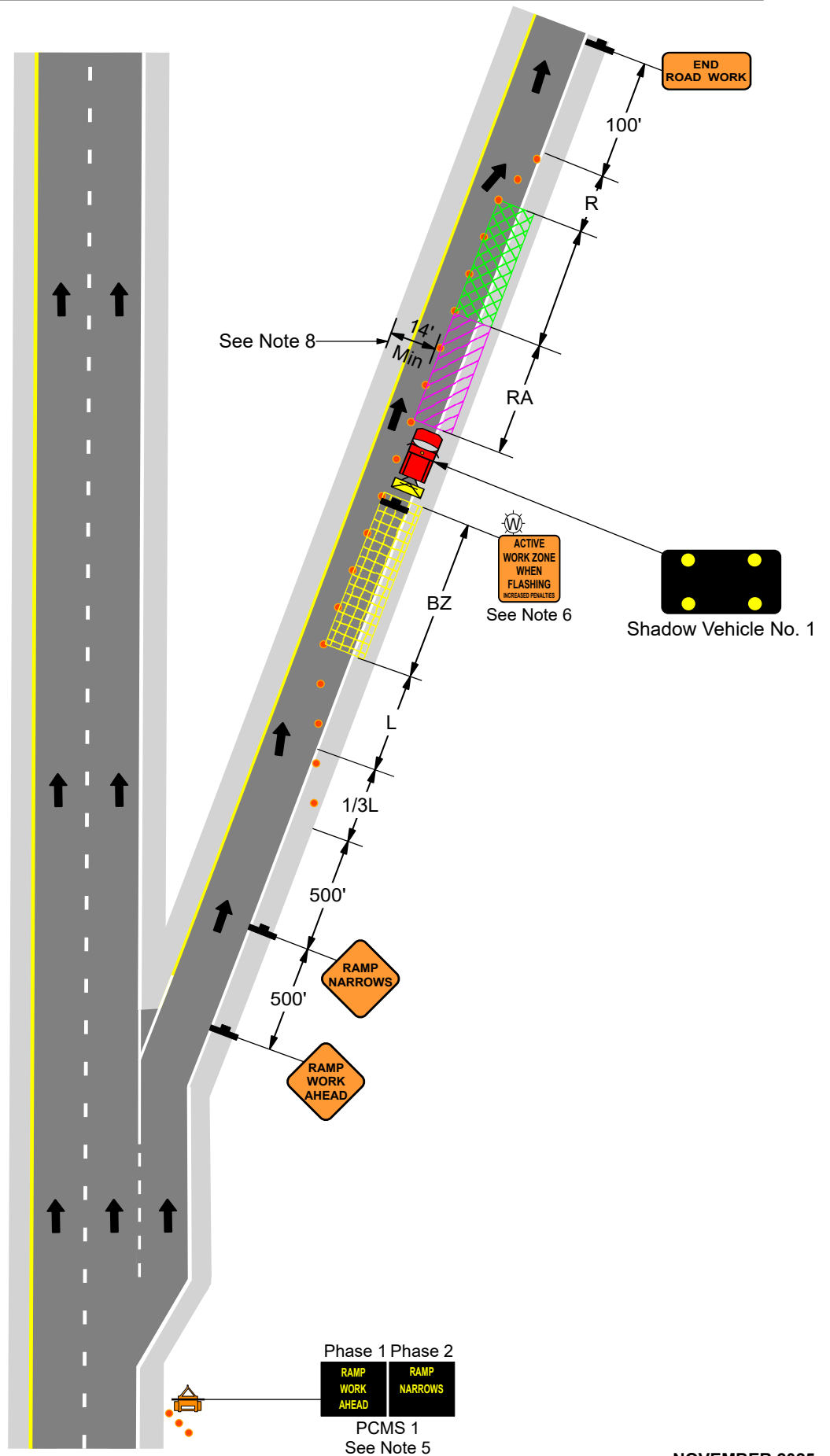

NOTES:
See PTS 940-11 - Notes for applicable notes to this drawing.

See Appendix A for sign descriptions and sizes.

Phase 1 Phase 2

RAMP WORK AHEAD	RAMP NARROWS
-----------------------	-----------------

 PCMS 1
 See Note 5

PTS 940-12 - Notes

Work Zone on Ramp with Temporary Barrier

1. Taper Barrier 30:1 to outside edge of paved shoulder. If full taper is not feasible, see Note 2.
2. Provide proper end treatment for barrier, by tapering barrier and burying, tapering barrier and connect to guide rail per PTS-135 or barrier, or tapering barrier and provide temporary impact attenuator with minimum 6 feet offset per PTS 009.
3. Place a PCMS a minimum of 500 feet in advance of ramp or 500 feet in advance of W21-101 sign, whichever is greater.
4. Provide 6 inch temporary waterborne paint lines the full length of temporary barrier.
5. Truck turning movements must be performed to verify a 14'-0" minimum travel lane will be adequate for WB-67 vehicle to safely traverse the ramp through the work area.

Signs

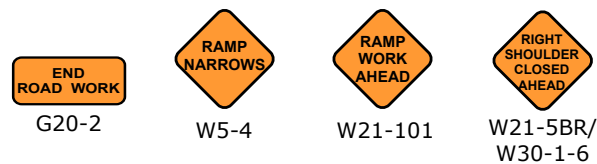

NOTE: See Appendix A for sign descriptions and dimensions.

Distance and Spacing Quick Reference Chart

SPEED	Shoulder	L	WZ	R	Maximum Channelizing Device Spacing (Feet)
MPH	Rate	Rate	Feet	Feet	L
Varies	30:1	50:1*	Varies	50	25

*Shifting taper rates may be reduced if applicable and approved by PTC Traffic Engineering unit.

L = Shifting Taper
 WZ = Work Zone
 R = Runout

PTS 940-12A Stationary Shoulder Closure on Ramp with Temporary Barrier

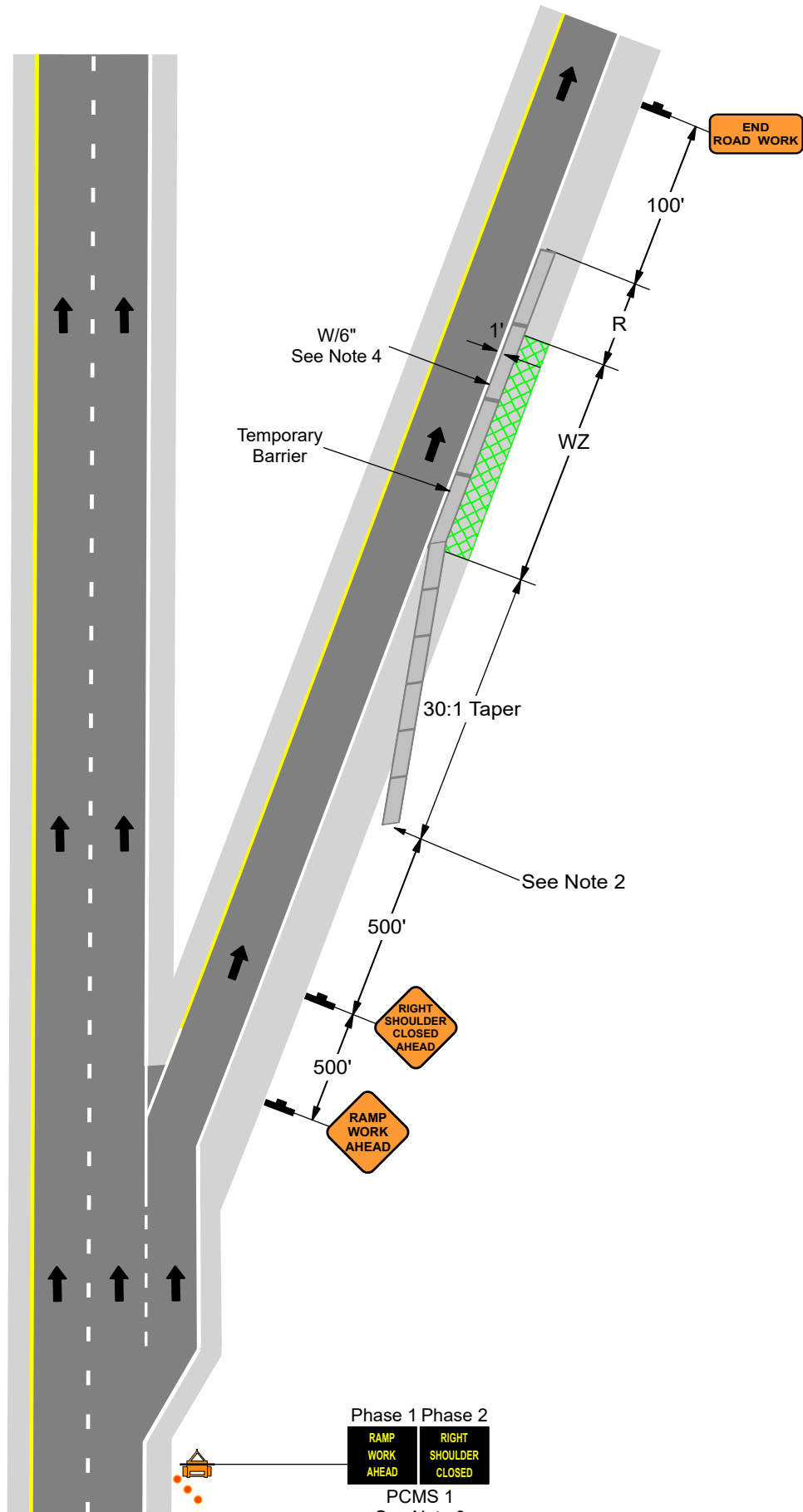

NOTES:
See PTS 940-12 - Notes for applicable notes to this drawing.

See Appendix A for sign descriptions and sizes.

PTS 940-12B Lane Narrows on Ramp with Temporary Barrier

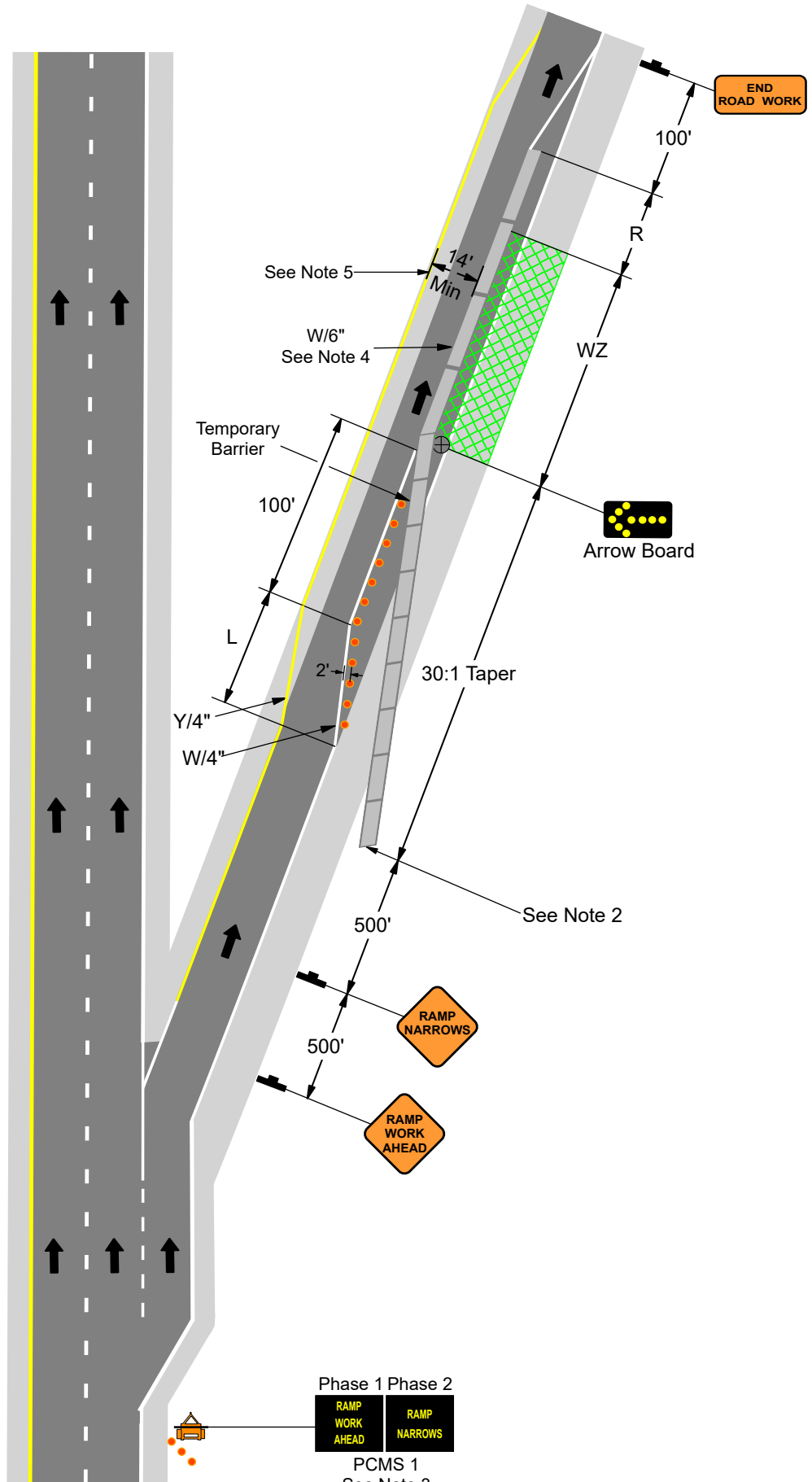

NOTES:
See PTS 940-12 - Notes for applicable notes to this drawing.

See Appendix A for sign descriptions and sizes.

PTS 940-13 - Notes

Single Lane Closure for Dual Lane Ramp

1. Taper barrier 30:1 to outside edge of paved shoulder. If full taper is not feasible, see Note 2.
2. Provide proper end treatment for barrier, by tapering barrier and burying, tapering barrier and connect to guide rail per PTS-135 or barrier, or tapering barrier and provide temporary impact attenuator with minimum 6 feet offset per PTS 009.
3. For left lane work zone, use the same sign spacing, location, and pattern but with the signs and PCMS indicating a left lane closure.
4. Use channelizing devices with PennDOT approved sequential warning lights in the taper area for patterns used during hours of darkness.
5. Single lane closure with channelizing devices for dual lane ramp will not be permitted when all lanes are required to be available in accordance with the allowable working hours or the specified holiday restrictions. Shorten length of single lane closure to only the length needed for construction operations.
6. Compute the minimum desirable merging taper length for reduction in lanes on ramps using the following formula:

$$L = \frac{W \times S_N^2}{60} \quad \text{Use for } S_N = 40 \text{ MPH or less.}$$

$$L = W \times S_N \quad \text{Use for } S_N > 40 \text{ MPH.}$$

Where L = Minimum desirable merging taper length in feet
W = Width of offset in feet
S_N = Normal speed in miles per hour

7. All arrow boards are to be truck-mounted or trailer-mounted and attached to the truck and shall move with the associated shadow vehicle.
8. Place PCMS a minimum of 500 feet in advance of ramp or 500 feet in advance of W21-101 sign, whichever is greater.
9. W21-19 is not required for PTC Maintenance Division Operations.
10. Provide 6 inch temporary waterborne paint lines the full length of temporary barrier.

Signs

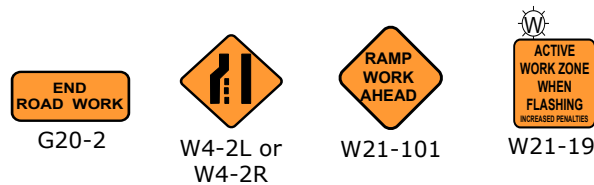

NOTE: See Appendix A for sign descriptions and dimensions.

Distance and Spacing Quick Reference Chart

SPEED	L	1/3 L	BZ	RA	WZ	R	Maximum Channelizing Device Spacing (Feet)		
							L & 1/3L	BZ, RA & WZ	R
MPH	Feet	Feet	Feet	Feet	Mile(s)	Feet	25	25	25
Varies	Varies	Varies	100	250	Varies	50	25	25	25

L = Merging Taper
1/3L = Shoulder Taper
BZ = Buffer Zone
RA = Roll Ahead Space
WZ = Work Zone
R = Runout

PTS 940-13A Single Lane Closure with Channelizing Devices for Dual Lane Ramp

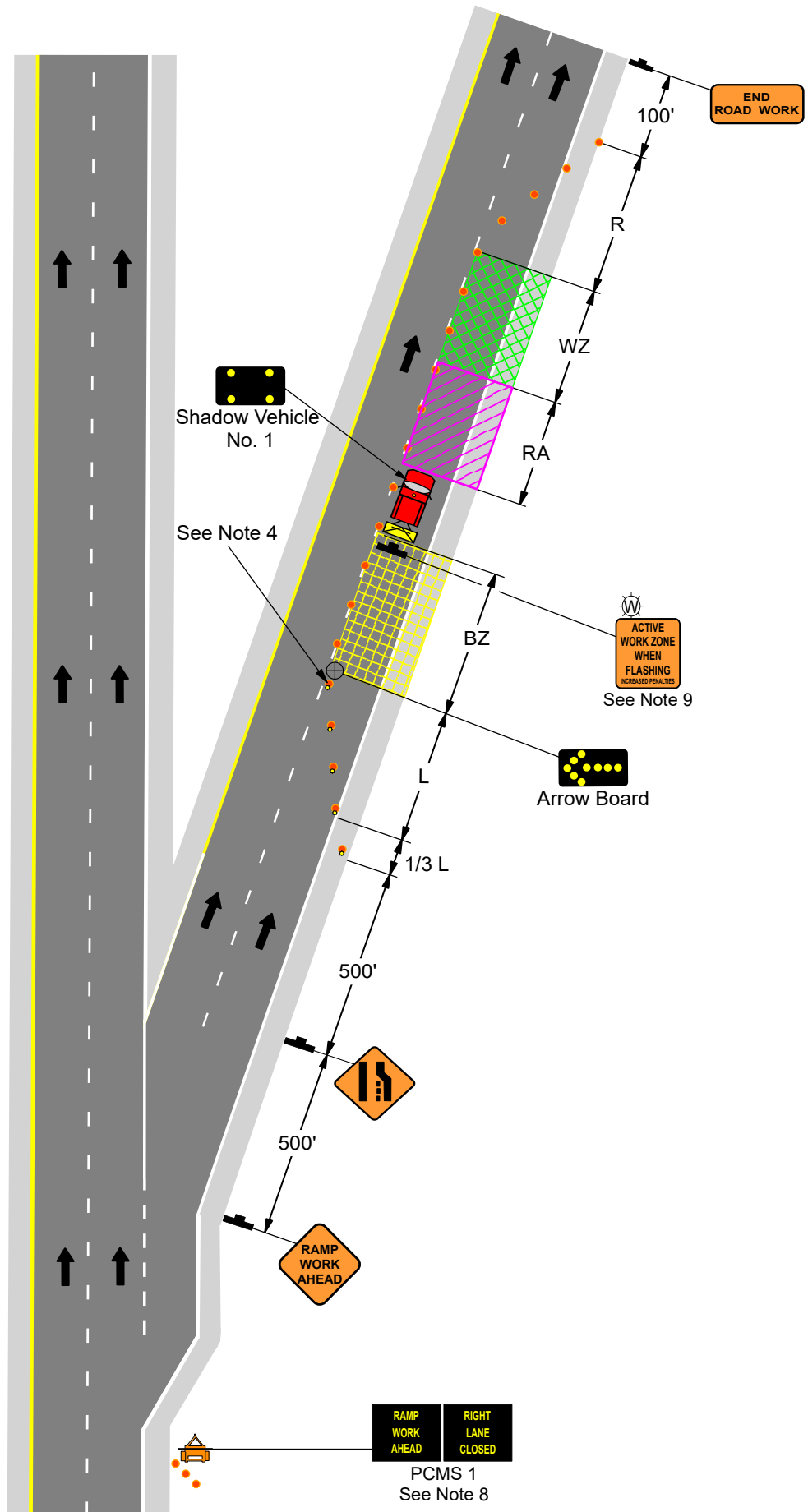

NOTES:
See PTS 940-13 - Notes for applicable notes to this drawing.

See Appendix A for sign descriptions and sizes.

RAMP WORK AHEAD **RIGHT LANE CLOSED**
PCMS 1
See Note 8

PTS 940-13B Single Lane Closure with Temporary Barrier for Dual Lane Ramp

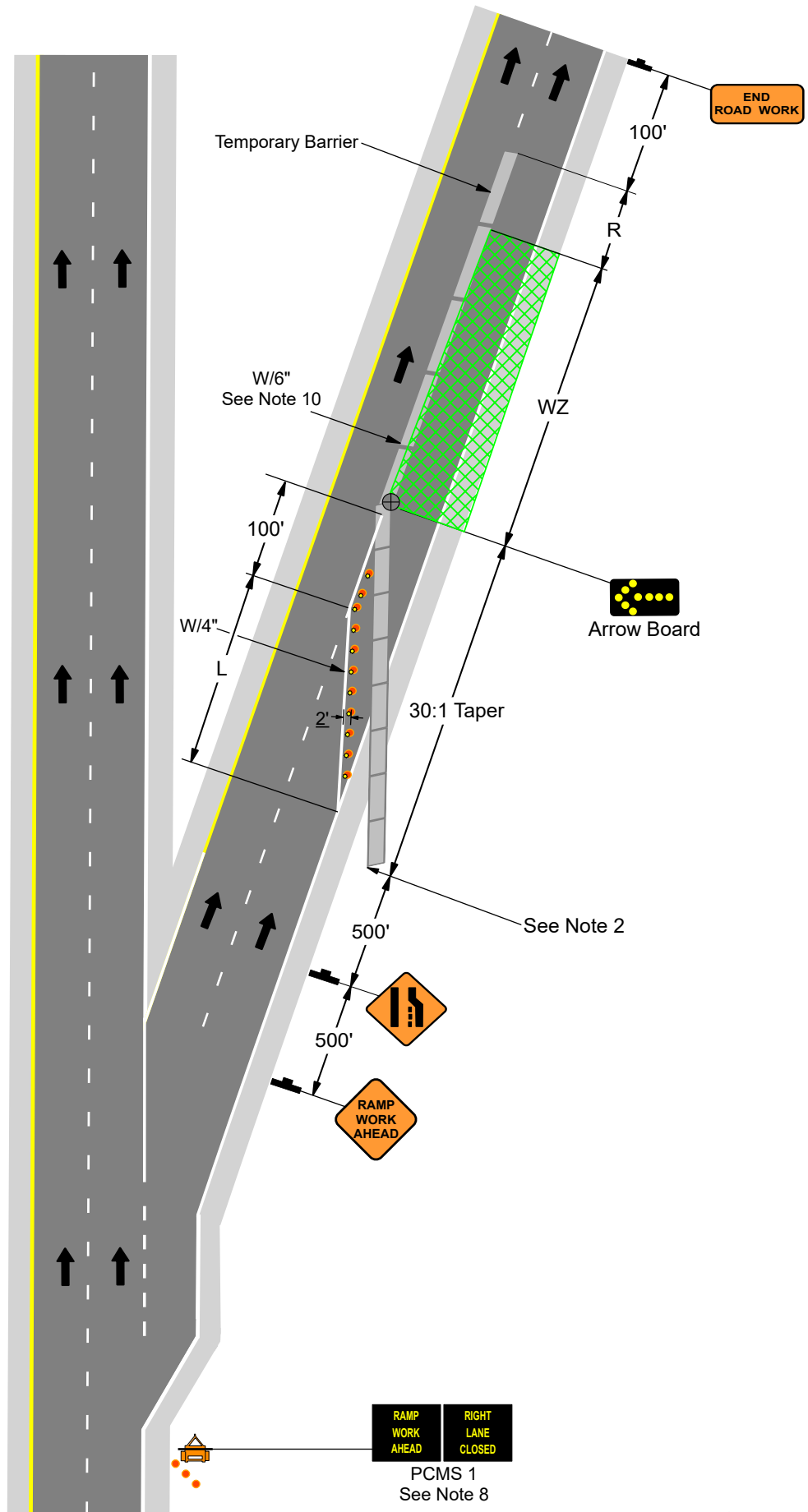

NOTES:
See PTS 940-13 - Notes for applicable notes to this drawing.

See Appendix A for sign descriptions and sizes.

PTS 940-14 - Notes

Slip Ramp Lane Closure with Channelizing Devices

1. Tie into shoulder at lane diverge.
2. Use channelizing devices with PennDOT approved sequential warning lights in the taper area for patterns used during hours of darkness.
3. Compute the minimum desirable merging taper length for reduction in lanes on ramps using the following formula:

$$L = \frac{W \times S_N^2}{60} \quad \text{Use for } S_N = 40 \text{ MPH or less.}$$

$$L = W \times S_N \quad \text{Use for } S_N > 40 \text{ MPH.}$$

Where L = Minimum desirable merging taper length in feet
W = Width of offset in feet
S_N = Normal speed in miles per hour

4. Slip ramp single lane closure with channelizing devices will not be permitted when all lanes are required to be available in accordance with the allowable working hours or the specified holiday restrictions.
5. W21-19 is not required for PTC Maintenance Division Operations.

Signs

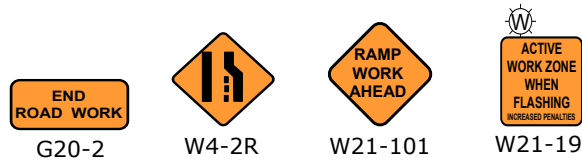

NOTE: See Appendix A for sign descriptions and dimensions.

Distance and Spacing Quick Reference Chart

SPEED	L	1/3 L	BZ	RA	WZ	R	Maximum Channelizing Device Spacing (Feet)		
							L & 1/3L	BZ, RA and WZ	R
MPH	Feet	Feet	Feet	Feet	Mile(s)	Feet	25	25	25
Varies	Varies	Varies	100	250	Varies	50	25	25	25

L = Merging Taper
1/3L = Shoulder Taper
BZ = Buffer Zone
RA = Roll Ahead Space
WZ = Work Zone
R = Runout

PTS 940-14A Slip Ramp - Lane Addition Closure with Channelizing Devices

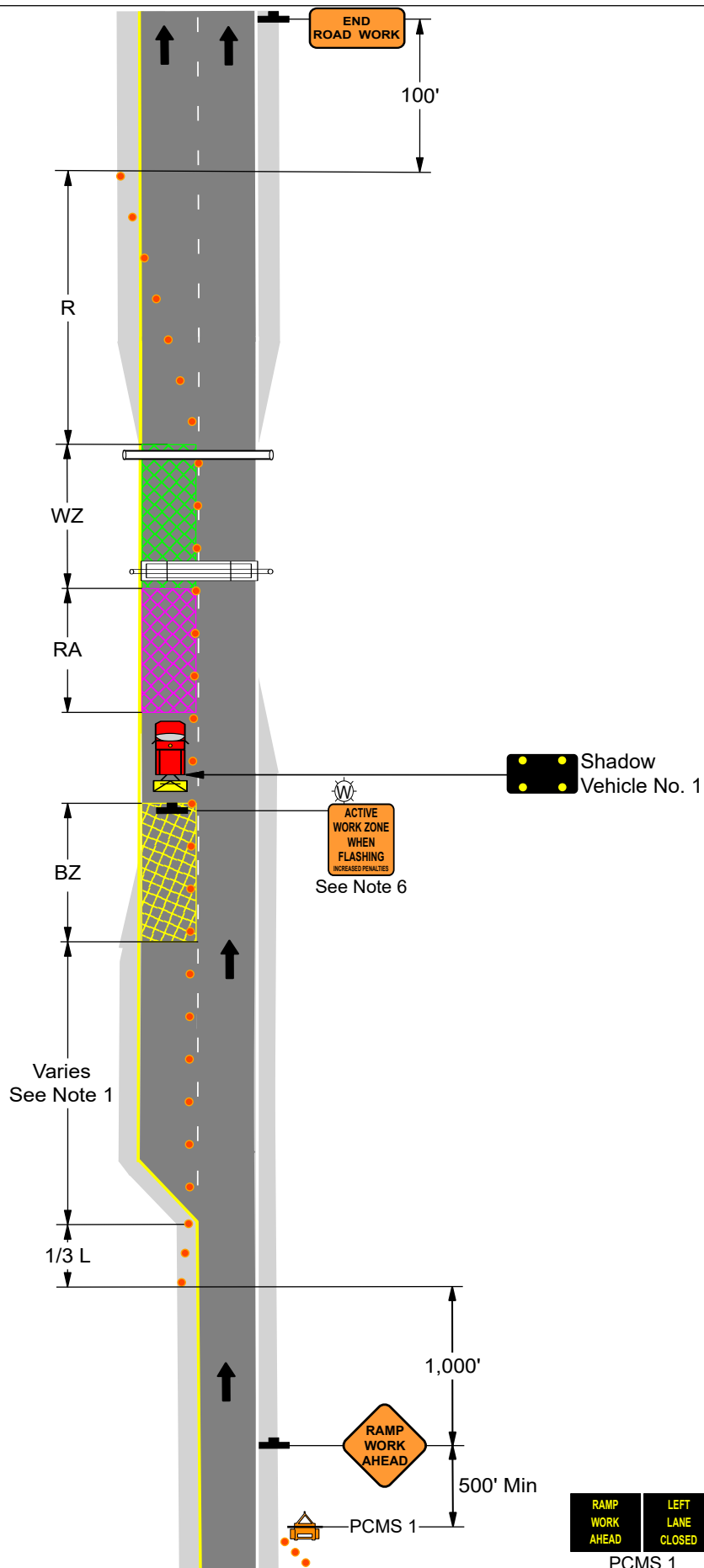

NOTES:
See PTS 940-14 - Notes for applicable notes to this drawing.

See Appendix A for sign descriptions and sizes.

RAMP WORK AHEAD	LEFT LANE CLOSED
-----------------------	------------------------

PTS 940-14B Slip Ramp - Lane Closure with Channelizing Devices

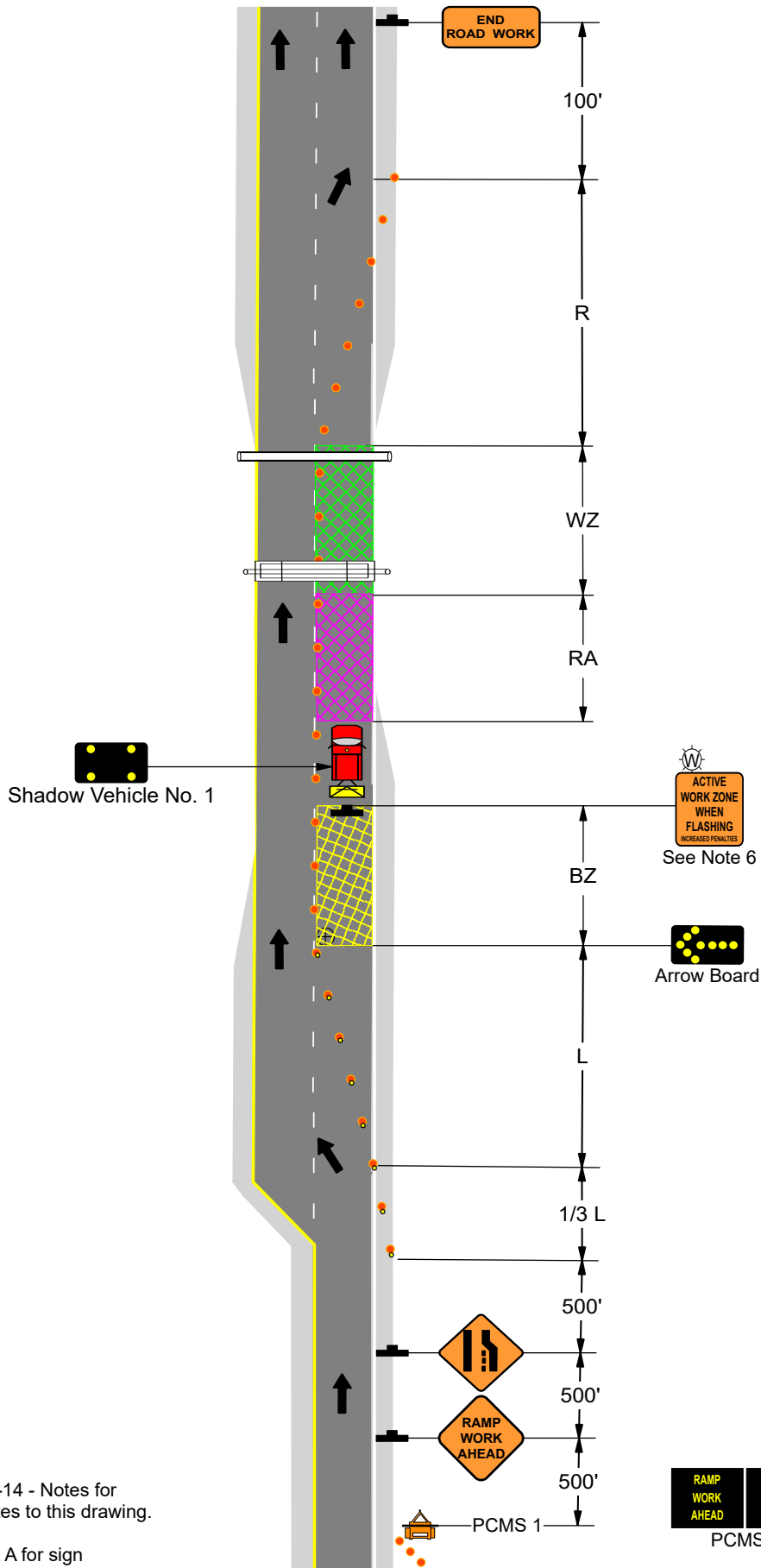

NOTES:
See PTS 940-14 - Notes for applicable notes to this drawing.

See Appendix A for sign descriptions and sizes.

PTS 940-15 - Notes

Traffic Line Painting Operation for Interchange Ramps

1. This figure applies to single and dual lane ramps where the distances between vehicles required on PTS 910-5 are not available.
2. A 7,000 lb GVW (Gross Vehicle Weight) or larger pickup truck and loaded to weigh a minimum of 5,500 lb may be used as Shadow Vehicle No. 1.
3. Position Shadow Vehicle No. 1 so that it is visible from behind for a minimum distance of 700 feet. If this sight distance cannot be obtained, use the maximum sight distance which the local geometry of the road allows.
4. All arrow boards and PCMS are to be truck-mounted or trailer-mounted and attached to the truck and shall move with the associated shadow vehicle.
5. The spacing between the work vehicles and the shadow vehicles, and between each shadow vehicle should be minimized to deter road users from driving in between, based on field conditions.
6. For traffic line painting on the left side of a single lane interchange ramp, use the same vehicles, spacing and pattern but with the PCMS and arrow board indicating traffic line painting on left side of ramp.
For left lane traffic line painting for a dual lane interchange ramp, use the same vehicles, spacing and pattern but with the PCMS and arrow board indicating a left lane closure.
7. Shadow Vehicles No. 3, No. 4 and No. 5 must be a single axle or tandem axle dump truck or a stake body truck. Light duty dump and light duty stake bodies are not permitted to be used as Shadow Vehicles No. 3, No. 4, and No. 5.
8. Paint Foreman's vehicle may be located:
 - A. In front of the supply vehicle,
 - B. Behind the supply vehicle, or
 - C. As a temporary replacement for Shadow Vehicle No. 2 for Traffic Line Painting Operation for Dual Lane Interchange Ramps.
9. State Police vehicle may be located:
 - A. In front of Shadow Vehicle No. 2 for single lane interchange ramp or Shadow Vehicle No. 4 for dual lane interchange ramp, or
 - B. Behind Shadow Vehicle No. 2. for single lane interchange ramp or Shadow Vehicle No. 4 for dual lane interchange ramp.
10. All vehicles, with exception of State Police vehicle, are to have an activated amber warning light.
11. If supply vehicle is not used, the distance from Shadow Vehicle No. 5 to Line Painting Machine shall be 300 feet.
12. All shadow vehicles are to have an arrow board or a PCMS.
13. Traffic line painting operations for interchange ramps will not be permitted when all lanes are required to be available in accordance with the allowable hours or the specified holiday restrictions.
14. This figure shall be used for projects using surface applied pavement markings, temporary or permanent.

PTS 940-15A
Traffic Line Painting Operation for Single Lane Interchange Ramps

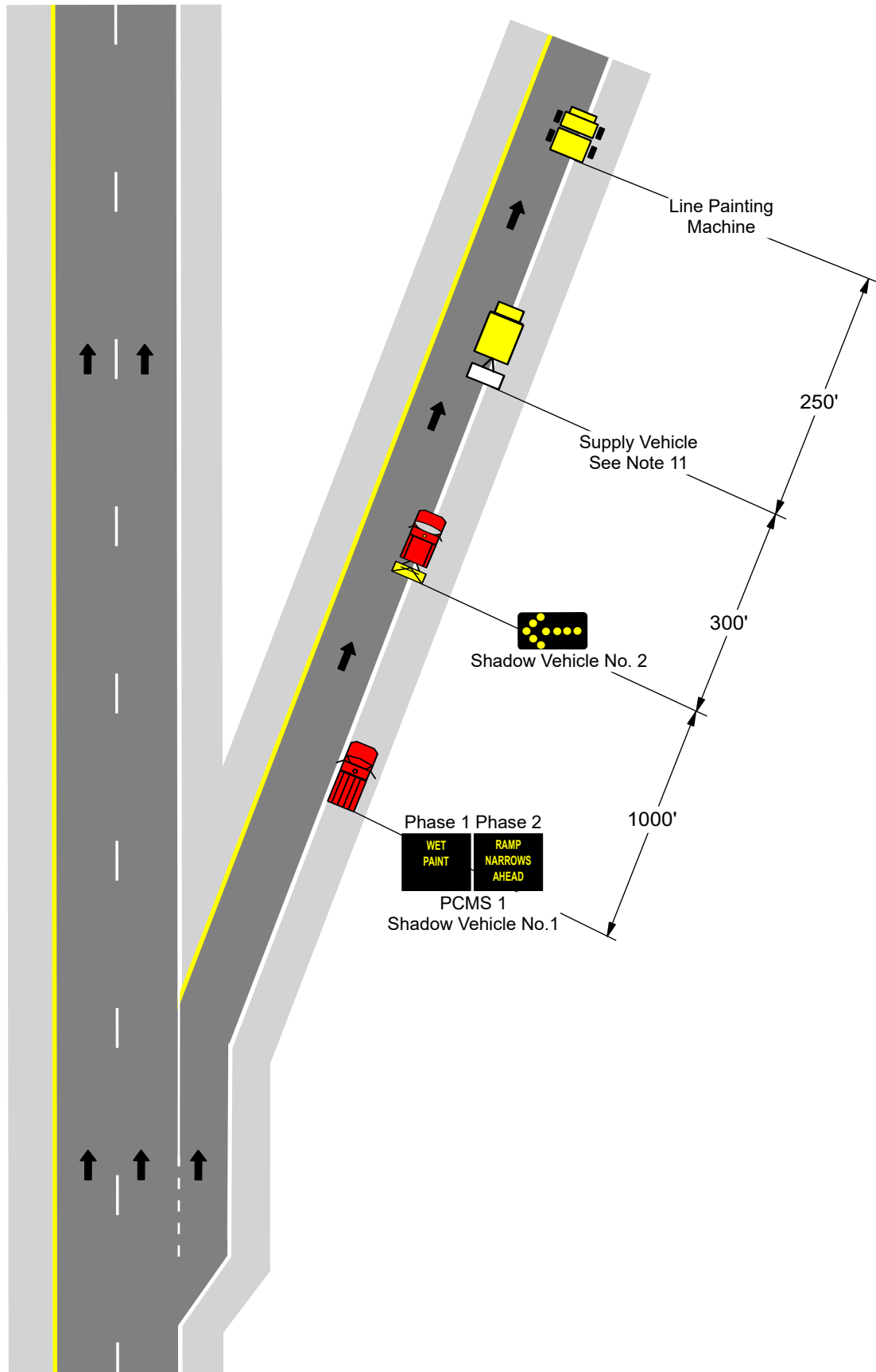

NOTES:
 See PTS 940-15 - Notes for
 applicable notes to this drawing.

PTS 940-15B Traffic Line Painting Operation for Dual Lane Interchange Ramps

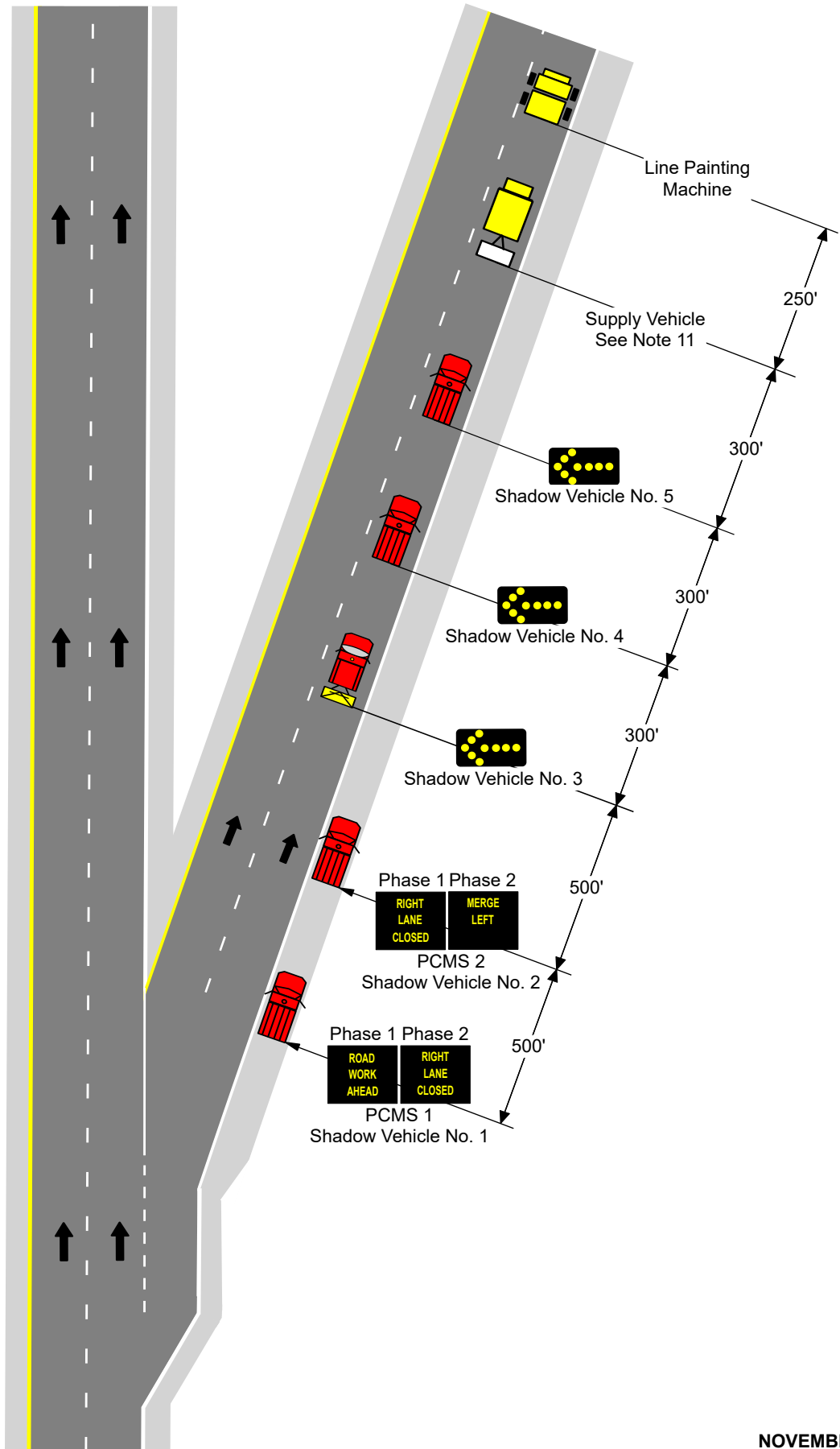

NOTES:
See PTS 940-15 - Notes for applicable notes to this drawing.

Appendix A
Sign Index In Nomenclature Order

NOMENCLATURE	DESCRIPTION	SIZE
D12-14A	EMERGENCY CELLULAR *11	30"x36"
G20-2	END ROAD WORK	60"x24"
G20-5AP	WORK ZONE PLAQUE	48"x36"
G30-1	EMERGENCY PULL-OFF	96"x60"
G30-2	EMERGENCY PULL-OFF ENTRANCE	96"x60"
MPT-01	CROSS OVER 500 FT	36"x48"
MPT-03	CROSS OVER 1000 FT	36"x48"
MPT-06	EXIT (45 DEGREE ARROW)	60"x60"
MPT-08	GAS AND FOOD (45 DEGREE ARROW)	60"x60"
MPT-10	TOLL PLAZA AREA CONSTRUCTION	96"x48"
MPT-31	NO SHOULDER __ MILES	96"x48"
MPT-34	SHOULDER CLOSED	48"x36"
MPT-36	HEAVY EQUIPMENT CROSSING	48"x48"
MPT-38	LEFT SHOULDER LOW	48"x48"
MPT-39	BOTH LANES CLOSED 1000 FT	48"x48"
PTC-LC	LANE CLOSED	48"x48"
PTC-LCA	LANE CLOSED AHEAD	48"x48"
R1-1	STOP	48"x48"
R1-1-2	RAMP	48"x24"
R1-1-3	RAMP STOP	48"x60"
R1-2	YIELD	60"x60"
R2-1	SPEED LIMIT	48"x60"
R4-1	DO NOT PASS	48"x60"
R4-1A	NO PASSING ZONE AHEAD	36"x48"
R5-1A	Wrong Way	42"x30"
R6-1R	One Way	48"x18"
R11-2	ROAD CLOSED	48"x30"
R22-1	WORK ZONE - TURN ON HEADLIGHTS	72"x48"
R23-101	SPEED LIMIT PHOTO ENFORCED	48"x48"

Appendix A
Sign Index In Nomenclature Order

NOMENCLATURE	DESCRIPTION	SIZE
W1-4L	LEFT REVERSE CURVE	48"x48"
W1-4R	RIGHT REVERSE CURVE	48"x48"
W1-4BL	TWO-LANE LEFT REVERSE CURVE	48"x48"
W1-4BR	TWO-LANE RIGHT REVERSE CURVE	48"x48"
W1-4CL	THREE-LANE LEFT REVERSE CURVE	48"x48"
W1-4CR	THREE-LANE RIGHT REVERSE CURVE	48"x48"
W3-1	STOP AHEAD	48"x48"
W3-2	YIELD AHEAD	48"x48"
W3-4	BE PREPARED TO STOP	48"x48"
W3-5	SPEED REDUCTION SIGN	48"x48"
W4-2L	PAVEMENT WIDTH TRANSITION - LEFT LANE ENDS	48"x48"
W4-2R	PAVEMENT WIDTH TRANSITION - RIGHT LANE ENDS	48"x48"
W5-4	RAMP NARROWS	48"x48"
W6-3	TWO-WAY TRAFFIC	48"x48"
W8-9	LOW SHOULDER	48"x48"
W8-11	UNEVEN LANES	48"x48"
W16-103P	DISTANCE AHEAD PLAQUE	36"x24"
W20-1	ROAD WORK	48"x48"
W20-5AL	LEFT TWO LANES CLOSED	48"x48"
W20-5AR	RIGHT TWO LANES CLOSED	48"x48"
W20-5L	LEFT LANE CLOSED	48"x48"
W20-5R	RIGHT LANE CLOSED	48"x48"
W20-7	FLAGGER SYMBOL	48"x48"
W21-5BL	LEFT SHOULDER CLOSED	48"x48"
W21-5BR	RIGHT SHOULDER CLOSED	48"x48"
W21-6	SURVEY CREW	48"x48"
W21-7	UTILITY WORK AHEAD	48"x48"
W21-10	STOP AND SLOW PADDLE	24"x24"
W21-19	ACTIVE WORK ZONE WHEN FLASHING	48"x48"

Appendix A
Sign Index In Nomenclature Order

NOMENCLATURE	DESCRIPTION	SIZE
W21-20	END ACTIVE WORK ZONE	48"x48"
W21-101	RAMP WORK AHEAD	48"x48"
W21-102	WORK AREA AHEAD	48"x48"
W24-1AL	TWO-LANE DOUBLE REVERSE CURVE LEFT	48"x48"
W24-1AR	TWO-LANE DOUBLE REVERSE CURVE RIGHT	48"x48"
W24-1BL	THREE-LANE DOUBLE REVERSE CURVE LEFT	48"x48"
W24-1BR	THREE-LANE DOUBLE REVERSE CURVE RIGHT	48"x48"
W25-5	CONSTRUCTION ENTRANCE AHEAD	48"x48"